



South Coast Air Quality Management District

21865 Copley Drive, Diamond Bar, CA 91765-4178
(909) 396-2000 • www.aqmd.gov

TO: SCAQMD Technology Committee
Joe Buscaino, Chair
Sheila Kuehl, Vice Chair
Larry McCallon, Judith Mitchell, Dwight Robinson, Janice Rutherford

FROM: Matt Miyasato, DEO, Science & Technology Advancement

TECHNOLOGY COMMITTEE

21865 Copley Drive, Diamond Bar, CA 91765
February 17, 2017 ♦ 12:00 p.m. ♦ Conference Room – CC-8

TELECONFERENCE LOCATIONS

Los Angeles City Hall	385 N. Arrowhead Avenue
200 N. Spring Street	Yucca Room
Room 410	San Bernardino, CA 92415
Los Angeles, CA 90012	

(The public may participate at any location listed above.)

Call-in for listening purposes only is available by dialing:

Toll Free: 866-244-8528

Listen Only Passcode: 5821432

In addition, a webcast is available for viewing and listening at:

<http://www.aqmd.gov/home/library/webcasts>

AGENDA

MARCH BOARD AGENDA ITEMS FOR ACTION/DISCUSSION

- 1. Execute Contract to Develop and Demonstrate Electric School Buses with Vehicle-to-Grid Capability** 
DOE recently awarded the Blue Bird Body Company, Inc. \$4,902,237 for the development and demonstration of electric school buses with vehicle-to-grid (V2G) capability. Blue Bird Body Company proposes to develop and manufacture V2G electric school buses and demonstrate them in the Rialto Unified School District (USD). Staff proposes to cost-share this project. This action is to execute a contract with Blue Bird Body Company for the development, manufacture and demonstration of electric school buses in an

Joseph Impullitti
Program
Supervisor

amount not to exceed \$1,900,000 from the Lower-Emission School Bus Fund (33).

2. Execute Contract to Develop and Demonstrate Medium-Heavy Duty (Class 5-7) Plug-in Hybrid Electric Vehicles for Work Truck Applications 

Seungbum Ha
AQ Specialist

DOE recently awarded \$2,932,193 to Odyne Systems, LLC, for the development and demonstration of a medium-heavy duty (Class 5-7) plug-in hybrid electric vehicle (PHEV) for work truck applications. Odyne proposes to develop and demonstrate medium-heavy duty (Class 5-7) PHEV work trucks with reduced fuel consumption and fully electrified jobsite functions. Staff proposes to cost-share this project. This action is to execute a contract with Odyne Systems, LLC, for the design, manufacture and demonstration of medium-heavy duty (Class 5-7) PHEV work trucks in an amount not to exceed \$900,000 from the Clean Fuel Fund (31).

3. Create Special Revenue Fund, Recognize and Transfer Funds, Execute Agreement for SCAQMD to Act as Supplemental Environmental Project Implementer for Installation of Air Filtration Systems, Execute Contract and Reimburse General Fund for Administrative Costs

Patricia Kwon
AQ Specialist

CARB and the Burlington Northern Sante Fe Railway Company (BNSF) are executing a Supplemental Environmental Project (SEP) agreement to install air filtration systems at school(s) in a local Environmental Justice community. Both parties have requested SCAQMD act as the SEP Implementer. These actions are to: 1) create the Air Filtration Fund (75); 2) recognize up to \$625,000 from BNSF into the Air Filtration Fund (75); and 3) transfer up to \$625,000 as a temporary loan from the Clean Fuels Fund (31) to the Air Filtration Fund (75). Furthermore, these actions are to execute an agreement with BNSF for SCAQMD to act as the SEP Implementer for this project, execute a contract with IQAir North America for installation of air filtration systems in an amount not to exceed \$593,750 and reimburse the General Fund for administrative costs up to \$31,250 from the Air Filtration Fund (75).

4. Transfer Funds, Execute Contract to Develop and Demonstrate Vessel Performance Management Software and Equipment and Amend Award

Naveen Berry
Technology
Demonstration
Manager

 The California State University Maritime Academy proposes to demonstrate a technology capable of harvesting high altitude wind energy while employing a vessel performance optimization system. The first two phases of the project includes the design and installation of the performance management software and equipment followed by demonstration of the equipment with performance evaluation of its fuel and emissions reductions capabilities. Staff proposes to cost-share phase 2 of this project with the California State University Maritime Academy, Maritime Administration and Bay Area AQMD. These actions are to transfer \$50,086 from the BP ARCO Settlement Projects Fund (46) into the Clean Fuels Fund (31), and execute a contract with the California State University Maritime Academy for the design and demonstration of vessel performance management software and equipment in an amount not to exceed \$50,086 from the Clean Fuels Fund

(31). Finally, this action is to amend a contractor's name from Ricardo Solutions to Ricardo, Inc., for a prior award.

5. Approve and Adopt Technology Advancement Office Clean Fuels Program 2016 Annual Report and 2017 Plan Update and Resolution, and Receive and File and Approve and Adopt Revised Membership of Technology Advancement and Clean Fuels Advisory Groups 

Naveen Berry

Each year by March 31, the Technology Advancement Office must submit to the California Legislative Analyst an approved Annual Report for the past year and a Plan Update for the current calendar year. Staff has reviewed the Clean Fuels Program with the Clean Fuels Advisory Group, the Technology Advancement Advisory Group and other technical experts. Additionally, the 2017 Clean Fuels Program Draft Plan Update was presented to the Technology Committee for review and comment at its October 21, 2016 meeting. This action is to approve and adopt the final Technology Advancement Clean Fuels Program Annual Report for 2016 and 2017 Plan Update as well as the resolution finding that proposed projects do not duplicate any past or present programs. This action is to also receive and file membership changes to the Technology Advancement Advisory Group and approve and adopt membership changes to the SB 98 Clean Fuels Advisory Group.

6. Other Business

Any member of the committee, or its staff, on his or her own initiative or in response to questions posed by the public, may ask a question for clarification; may make a brief announcement or report on his or her own activities, provide a reference to staff regarding factual information, request staff to report back at a subsequent meeting concerning any matter, or may take action to direct staff to place a matter of business on a future agenda. (Govt Code Section 54954.2)

7. Public Comment Period

Members of the public may address this body concerning any agenda item before or during consideration of that item (Govt. Code Section 54954.3). All agendas for regular meetings are posted at District Headquarters, 21865 Copley Drive, Diamond Bar, California, at least 72 hours in advance of a regular meeting. At the end of the regular meeting agenda, an opportunity is also provided for the public to speak on any subject within this body's authority. Speakers may be limited to three (3) minutes each.

Next Meeting: March 17, 2017 at SCAQMD Headquarters in CC-8

Document Availability

All documents (i) constituting non-exempt public records; (ii) relating to an item on the agenda for a regular meeting; and (iii) having been distributed to at least a majority of the Technology Committee after the agenda is posted, are available prior to the meeting for public review at the South Coast Air Quality Management District Public Information Center, 21865 Copley Drive, Diamond Bar, CA 91765.

Americans with Disabilities Act

The agenda and documents in the agenda packet will be made available, upon request, in appropriate alternative formats to assist persons with a disability. Disability-related accommodations will also be made available to allow participation in the Technology Committee meeting. Any accommodations must be requested as soon as practicable. Requests will be accommodated to the extent feasible. Please contact Pat Krayser at 909-396-3248 from 7:00 a.m. to 5:30 p.m., Tuesday through Friday, or send the request to pkrayser@aqmd.gov.

[Go to SLIDES](#)

DRAFT
Technology Committee Agenda #1

BOARD MEETING DATE: March 3, 2017

AGENDA NO.

PROPOSAL: Execute Contract to Develop and Demonstrate Electric School Buses with Vehicle-to-Grid Capability 

SYNOPSIS: DOE recently awarded the Blue Bird Body Company, Inc. \$4,902,237 for the development and demonstration of electric school buses with vehicle-to-grid (V2G) capability. Blue Bird Body Company proposes to develop and manufacture V2G electric school buses and demonstrate them in the Rialto Unified School District. Staff proposes to cost-share this project. This action is to execute a contract with Blue Bird Body Company for the development, manufacture and demonstration of electric school buses in an amount not to exceed \$1,900,000 from the Lower-Emission School Bus Fund (33).

COMMITTEE: Technology, February 17, 2017; Recommended for Approval

RECOMMENDED ACTION:

Authorize the Chairman to execute a contract with Blue Bird Body Company for the development, manufacture and demonstration of electric school buses in an amount not to exceed \$1,900,000 from the Lower-Emissions School Bus Fund (33).

Wayne Nastri
Executive Officer

MMM:FM:NB:JI

Background

Blue Bird Body Company (Blue Bird) is one of the largest suppliers of school buses in the South Coast and has previously developed and commercialized alternative fuel buses. Blue Bird has been investigating methods of introducing electric vehicles into the national school bus market for the last decade. In 2010, Blue Bird hired consulting firm National Strategies, LLC, (NSI) to conduct an independent evaluation of market entry strategies. In 2015, Blue Bird reengaged with NSI and in parallel conducted its own independent evaluation of potential electric drivetrain suppliers. At the end of the process, Blue Bird reaffirmed the selection of TransPower, located in Escondido,

California, as the company best qualified to support development of battery-electric school bus technologies and components. With TransPower's input, Blue Bird has taken the lead role in moving electric school buses toward commercial production. For nearly a year, Blue Bird and TransPower have been collaborating to develop designs, test procedures and manufacturing plans to enable mass production of Blue Bird buses using electric drive components developed by TransPower.

Two prototype buses were previously developed by NSI and TransPower, cofunded by the SCAQMD, and are currently being demonstrated by the Torrance Unified School District (USD).

As a follow-up to the prototype buses, Blue Bird applied to the DOE for funding to further develop components and systems required for the commercialization of electric school buses. The DOE recently awarded Blue Bird \$4,902,237 to develop, manufacture and demonstrate eight electric school buses with vehicle-to-grid (V2G) capabilities in the Rialto USD.

Proposal

Blue Bird proposes to develop a plug-in battery-electric drive system optimized for use in Types C and D (Class 6-7) school buses with V2G and vehicle-to-building (V2B) power export capabilities. The project goal is to advance the technology readiness of medium-duty electric drive components developed by TransPower and subject them to Blue Bird's intensive testing and certification procedures.

Blue Bird's strategy is to improve performance and efficiency, thereby reducing operating costs, and create new opportunities for school districts to generate revenues through the export of battery power to the grid. This strategy led the Blue Bird team to select three critical powertrain technologies for refinement: automated manual transmission (AMT), battery management system (BMS) and inverter-charger unit (ICU). TransPower's AMT allows the drive motor to operate at peak efficiency across the vehicle speed range without performance compromises. Further energy system gains can be achieved with advanced BMS technologies that are being developed by TransPower. These technologies promise to minimize parasitic energy losses and optimize usable energy from a battery subsystem of a given size. Finally, the high-efficiency ICU used in TransPower's drive system further enhances efficiency, facilitates export of power to external markets, and enables VTB capability in support of micro-grid and emergency response scenarios.

In the proposed project, the team will focus on building four electric school buses that will be subjected to Blue Bird's usual safety and durability test program. This includes crash testing of one to two buses and durability testing of another. This will be followed by the manufacture and integration of eight additional buses to be deployed by Rialto USD.

The eight production buses, upon receipt of certification from the California Highway Patrol, will be placed into service with Rialto USD. The final task will be development of a Market Transformation Plan describing how Blue Bird, with the assistance of its team members, will commercialize electric school buses using the demonstrated drive system.

Sole Source Justification

Section VIII.B.2 of the Procurement Policy and Procedure identifies provisions by which sole source awards may be justified. This request for a sole source award is made under provision B.2.d: Other circumstances exist which in the determination of the Executive Officer requires such waiver in the best interest of the SCAQMD. This request for sole source award is made under provision B.2.d(1): Projects involving cost-sharing by multiple sponsors. Project partners include the DOE, TransPower, Rialto USD, Blue Bird Body Co, and NSI.

Benefits to SCAQMD

Projects to support implementation of various clean fuel vehicle incentive programs are included in the *Technology Advancement Office Clean Fuels Program 2017 Plan Update* under the core category of “Electric/Hybrid Technologies & Infrastructure”. This project is to develop and demonstrate zero emission electric school buses with V2G capability. Successful demonstration of such projects will contribute to the attainment of clean air standards in the South Coast Air Basin by eliminating PM and NOx emissions from replaced diesel and alternative fuel school buses.

Resource Impacts

The total cost for this proposed project is \$9,804,528, with cash contributions comprised of \$4,902,237 from DOE, \$160,000 from Rialto USD and up to \$1,900,000 proposed from the SCAQMD from the Lower-Emissions School Bus Fund (33). In addition, a combination of cash and in-kind contributions are comprised of \$2,648,653 from TransPower, \$128,040 from Blue Bird and \$65,598 from NSI. Proposed funding is broken down in the table below.

Table: Proposed Funding

Project Partner	Funding Amount	Percent
DOE	\$4,902,237	50%
TransPower	\$2,648,653	27%
Rialto USD	\$160,000	2%
Blue Bird Body Co.	\$128,040	1%
NSI	\$65,598	1%
SCAQMD (<i>requested</i>)	\$1,900,000	19%
Total	\$9,804,528	100%

Agenda Item # 1

Joseph Impullitti

Execute Contract to Develop and
Demonstrate Electric School Buses with
Vehicle-to-Grid Capability 

Background

- Blue Bird North America
 - Leader in alternative fuel buses
 - Approximately 30% market share
 - Actively pursuing electric school buses
- Two vehicle-to-grid (V2G) electric bus prototypes
 - Developed by TransPower
 - Cofunded by SCAQMD
 - Will be deployed at Torrance USD
- DOE awarded Blue Bird \$4.9M to develop and demonstrate electric school buses with V2G capability



Proposal

- Blue Bird proposes to develop battery-electric drive for Type C and D school buses with V2G and vehicle-to-building (V2B) power export
- Electric drive and inverter-charger supplied by TransPower
- V2G – potential revenue stream by exporting power to grid



Proposal (cont'd)

- V2B will support micro-grid and emergency response
- Eight production buses, with CHP certification, will be placed into service at Rialto USD
- Blue Bird will develop a Market Transformation Plan



Proposed Project Costs

Develop and Demonstrate Electric School Buses
with V2G Capability

Source	Contribution	Percent
DOE	\$4,902,237	50
TransPower	\$2,648,653	27
Rialto USD	\$160,000	2
Blue Bird Body Co.	\$128,040	1
NSI	\$65,598	1
SCAQMD (<i>requested</i>)	\$1,900,000	19
Total	\$9,804,528	100

Recommended Action

Execute contract with Blue Bird Body Company, Inc., to develop, manufacture and demonstrate electric school buses in an amount not to exceed \$1.9M from Lower-Emission School Bus Fund (33).

DRAFT
Technology Committee Agenda #2

BOARD MEETING DATE: March 3, 2017

AGENDA NO.

PROPOSAL: Execute Contract to Develop and Demonstrate Medium-Heavy Duty (Class 5-7) Plug-in Hybrid Electric Vehicles for Work Truck Applications 

SYNOPSIS: DOE recently awarded \$2,932,193 to Odyne Systems, LLC, for the development and demonstration of a medium-heavy duty (Class 5-7) plug-in hybrid electric vehicle (PHEV) for work truck applications. Odyne proposes to develop and demonstrate medium-heavy duty (Class 5-7) PHEV work trucks with reduced fuel consumption and fully electrified jobsite functions. Staff proposes to cost-share this project. This action is to execute a contract with Odyne Systems, LLC, for the design, manufacture and demonstration of medium-heavy duty (Class 5-7) PHEV work trucks in an amount not to exceed \$900,000 from the Clean Fuel Fund (31).

COMMITTEE: Technology, February 17, 2017; Recommended for Approval

RECOMMENDED ACTION:

Authorize the Chairman to execute a contract with Odyne Systems, LLC, for the development and demonstration of medium-heavy duty (Class 5-7) plug-in hybrid electric vehicles for work truck applications in an amount not to exceed \$900,000 from the Clean Fuels Fund (31).

Wayne Natri
Executive Officer

MMM:FM:NB:SH

Background

Odyne Systems, LLC, is a clean technology company that develops and manufactures propulsion systems for medium- and heavy-duty plug-in hybrid electric vehicles (PHEVs). Odyne has developed proprietary and patented hybrid technology combining electric power conversion, power control and energy storage technology with standard electric motors, storage batteries and other components. Odyne's plug-in hybrid

technology has been applied to commercial truck applications including bucket trucks, digger derricks and compressor trucks. These development efforts have also benefited from a \$50 million program funded through the DOE and CEC, with programmatic administration by the SCAQMD. The existing development efforts have yielded a modular PHEV system that can be installed on new and retrofit vehicles, as the packaging requirements of the hybrid system need to be taken into account during the vehicle's initial build. Additional engineering efforts are needed to develop a system that has lower emissions, improved performance, quiet jobsite operation, lower fuel consumption and reduced operating and maintenance costs.

Proposal

Odyne proposes to partner with the Freightliner Trucks, Allison Transmission, National Renewable Energy Laboratory (NREL), Oak Ridge National Laboratory (ORNL), Duke Energy, Sempra Energy, AVL, LG Chem and SCAQMD to design, develop and demonstrate a new generation of medium-heavy duty (Class 5-7) PHEV work truck that achieves a significant reduction in fuel consumption versus a conventional vehicle baseline. The plug-in hybrid technology will include idle reduction, launch assist, regenerative braking, in-cab climate controls and exportable power, improving vehicle efficiency while driving and eliminating idling and emissions during operation at a jobsite. This proposal addresses significant improvements in powertrain integration and adaptive control, a higher level of hybridization, fully electric jobsite operation and a low-cost modular battery pack solution through integrated three development streams into a final vehicle.

The development and demonstration project will include the following:

- *Powertrain Development and Optimization:* Odyne, ORNL, Allison Transmission and Freightliner Trucks will develop an integrated PHEV powertrain simulation, develop optimization strategies against real-world vocational duty cycles provided by NREL's analysis of a prior DOE medium-duty heavy-duty (MD-HD) work truck fleet, and validate the resulting system on ORNL's hardware-in-the-loop facility.
- *Battery System Development:* AVL, in conjunction with LG Chem and Odyne, will develop and validate a modular battery system based on commercially available light-duty cells and modules which will meet the performance requirements of the target vocational truck market as established by NREL's analysis of the full-day and full-year work cycles of a vocational MD-HD work truck fleet.
- *Vehicle Integration:* Odyne will work with Freightliner Trucks to integrate the PHEV powertrain, battery system, control systems and electrified jobsite equipment into the medium-heavy duty (Class 5-7) vocational work truck. NREL will provide testing and full cycle analysis of the final test vehicle and will monitor and provide summary results of the evaluation fleet.

- *Demonstration:* Ten trucks will be demonstrated in operation for a period of 12 months, five by Duke Energy in Duke Energy's service territory (the Carolinas, the Midwest and Florida) and five by Sempra Energy in SCAQMD's jurisdiction. These vehicles will consist of bucket, underground service or similar medium-heavy duty vocational work trucks. If Sempra Energy (including affiliate Southern California Gas Company) cannot commit to locating five vehicles in the designated area, other utilities including Los Angeles Department of Water & Power have expressed interest in fulfilling the commitment of cost-share and SCAQMD deployment.

The goals of the project are to significantly reduce fuel use and emissions, reduce costs through integration of high volume battery modules, system and component cost reductions, and further integration of the hybrid, vehicle and powertrain systems, ultimately leading to air quality benefit and an improved return on investment.

Sole Source Justification

Section VIII.B.2 of the Procurement Policy and Procedure identifies four major provisions under which a sole source award may be justified. This request for a sole source award is made under provision B.2.d.: Other circumstances exist which in the determination of the Executive Officer require such waiver in the best interest of the SCAQMD. Specifically, these circumstances are: B.2.d.(1) Project involving cost sharing by multiple sponsors. The multiple sponsors contributing financially to this project include DOE and Odyne.

Odyne, the PHEV system installer, is the project leader. Odyne offers the plug-in hybrid system on a medium- or heavy-duty truck that delivers greater fuel efficiency both while driving and at the worksite. The company sells its unique modular system for new and retrofit applications direct to truck manufacturers and through a global distribution and service network including Altec, Terex Utilities and selected Allison Transmission distributors.

The vehicle chassis manufacturer, Freightliner, is supporting the project through systems engineering of the PHEV integration and vehicle control system interface. Allison Transmission (key supplier to Freightliner) will play a key role in powertrain optimization, providing a hybrid-integrated transmission controller, advanced shift and transmission technologies and final shift schedule development, helping to maximize fuel reduction. NREL will provide duty-cycle analysis, fuel savings simulation and baseline, and final vehicle dynamometer testing.

ORNL will provide a lead role in powertrain simulation, optimization and test. Odyne has worked with major battery suppliers and has chosen AVL as the energy storage design and integration partner. AVL will utilize LG Chem cells manufactured in

Michigan, leveraging the high volume production of this technology in the light-duty sector (e.g., Chevy Bolt and Volt).

Benefits to SCAQMD

The work-truck segment targeted by Odyne is almost exclusively made up of medium- and heavy-duty vehicles. This vehicle weight group is responsible for creating a disproportionate amount of emissions in the South Coast Air Basin, since they represent a relatively small percentage of the vehicle population yet are responsible for the majority of the NOx and particulate matter emissions. This project provides an opportunity to significantly reduce NOx and particulate matter emissions through the introduction of a relatively small number of cleaner transportation technologies. The hybridization and electrification of vehicles in this segment provides one such opportunity to reduce emissions. Additionally, eliminating the need for idling, especially in residential communities, minimizes localized exposure and noise issues.

Advancement of hybrid vehicle technologies is included in the *Technology Advancement Office Clean Fuels Program 2017 Plan Update* under the core category of “Electric/Hybrid Technologies & Infrastructure.” The hybridization of transportation technologies has the potential to lower criteria pollutant emissions and reduce greenhouse gas emissions. This can provide substantial air quality benefits to communities, neighborhoods and schools where these vehicles operate.

Resource Impacts

The total cost for the project is \$6,955,281, with SCAQMD’s proposed cost-share not to exceed \$900,000 from the Clean Fuels Fund (31). The project funding sources are identified below.

Project Partners	Funding Amount	Percent
DOE	\$2,932,193	42
Odyne Systems, LLC	\$1,033,088	15
Freightliner	\$65,000	1
Allison Transmission	\$25,000	1
Sempra Energy (in-kind)	\$1,000,000	14
Duke Energy (in-kind)	\$1,000,000	14
SCAQMD (<i>requested</i>)	\$900,000	13
Total	\$6,955,281	100

Sufficient funds are available in the Clean Fuels Fund (31) for this proposed project. The Clean Fuels Fund (31) is established as a special revenue fund resulting from the state-mandated Clean Fuels Program. The Clean Fuels Program, under Health and

Safety Code Sections 40448.5 and 40512 and Vehicle Code Section 9250.11, establishes mechanisms to collect revenues from mobile sources to support projects to increase the utilization of clean fuels, including the development of the necessary advanced enabling technologies. Funds collected from motor vehicles are restricted, by statute, to be used for projects and program activities related to mobile sources that support the objectives of the Clean Fuels Program.

Agenda Item #2

Seungbum Ha

Execute Contract to Develop and Demonstrate Medium-Heavy Duty (Class 5-7) Plug-In Hybrid Electric Vehicles for Work Truck Applications 

Background

- Existing development efforts include modular PHEV systems for new and retrofits
- Critical to develop PHEV work truck with no idling at jobsite and lower emissions
- DOE awarded Odyne Systems, LLC, grant funds of \$2,932,193



Current Efforts

- Previously funded project: development of a plug-in hybrid medium-heavy duty truck
- Fuel economy/idling reductions achieved
- Medium-heavy duty (M/HD) PHEV work truck typical operation
 - Low vehicle miles travelled (VMT)
 - Electrification jobsites operation

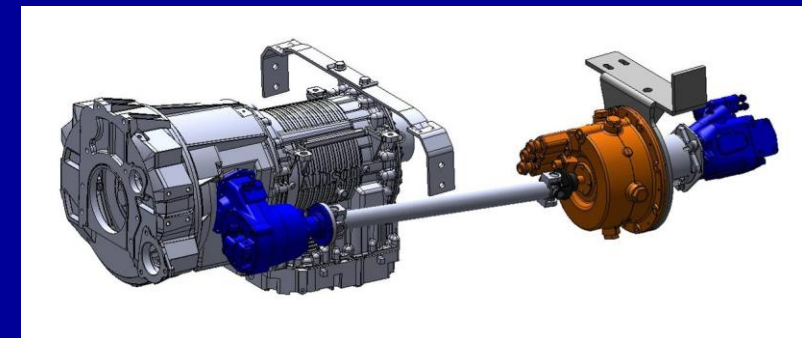
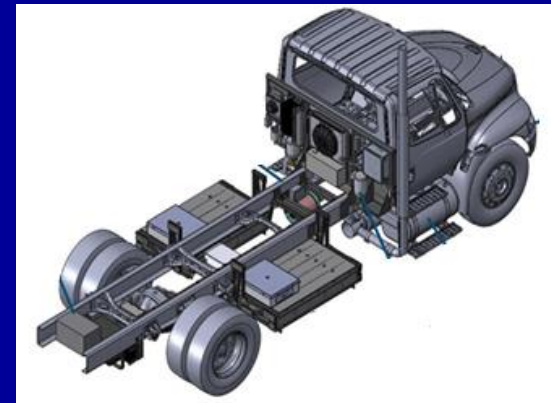
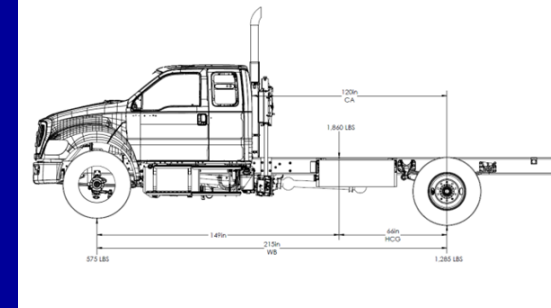

Proposal

- Develop and demonstrate M/HD PHEV work trucks
 - Simulation model for powertrain development and optimization
 - Battery system development
 - Vehicle integration
 - PHEV powertrain and control system
 - Battery system
 - Electrified jobsite equipment
- 12-month demonstration period
 - 5 in South Coast – Sempra Energy and others
 - 5 in Southeast US – Duke Energy



Proposed Project Cost

Project Partners	Funding Amount	Percent
Department of Energy	\$2,932,193	42
Odyne Systems, LLC	\$1,033,088	15
Freightliner	\$65,000	1
Allison Transmission	\$25,000	1
Sempra Energy (in-kind)	\$1,000,000	14
Duke Energy (in-kind)	\$1,000,000	14
SCAQMD (<i>requested</i>)	\$900,000	13
Total	\$6,955,281	100

Recommended Action

Execute a contract with Odyne Systmes, LLC, for the development and demonstration of medium-heavy duty (Class 5-7) PHEV for work truck applications in an amount not to exceed \$900,000 from the Clean Fuels Fund (31)

DRAFT
Technology Committee Agenda #3

BOARD MEETING DATE: March 3, 2017

AGENDA NO. x

PROPOSAL: Create Special Revenue Fund, Recognize and Transfer Funds, Execute Agreement for SCAQMD to Act as Supplemental Environmental Project Implementer for Installation of Air Filtration Systems, Execute Contract and Reimburse General Fund for Administrative Costs

SYNOPSIS: CARB and the Burlington Northern Sante Fe Railway Company (BNSF) are executing a Supplemental Environmental Project (SEP) agreement to install air filtration systems at school(s) in a local Environmental Justice community. Both parties have requested SCAQMD act as the SEP Implementer. These actions are to: 1) create the Air Filtration Fund (75); 2) recognize up to \$625,000 from BNSF into the Air Filtration Fund (75); and 3) transfer up to \$625,000 as a temporary loan from the Clean Fuels Fund (31) to the Air Filtration Fund (75). Furthermore, these actions are to execute an agreement with BNSF for SCAQMD to act as the SEP Implementer for this project, execute a contract with IQAir North America for installation of air filtration systems in an amount not to exceed \$593,750 and reimburse the General Fund for administrative costs up to \$31,250 from the Air Filtration Fund (75).

COMMITTEE: Technology, February 17, 2017; Recommended for Approval

RECOMMENDED ACTIONS:

1. Create the Air Filtration Fund (75);
2. Recognize, upon receipt, up to \$625,000 from BNSF into the Air Filtration Fund (75);
3. Transfer up to \$625,000 as a temporary loan from the Clean Fuels Fund (31) into the Air Filtration Fund (75);
4. Authorize the Executive Officer to execute an agreement with BNSF for SCAQMD to act as the SEP Implementer for installation of air filtration systems;
5. Authorize the Chairman to execute a contract with IQAir North America for installation of air filtration systems at one or more schools in an amount not to exceed \$593,750 from the Air Filtration Fund (75); and

6. Reimburse the General Fund from the Air Filtration Fund (75) for administrative costs up to \$31,250 as needed to implement the air filtration project.

Wayne Natri
Executive Officer

MMM:FM:NB:PSK

Background

CARB and the Burlington Northern Sante Fe Railway Company (BNSF) are executing a Supplemental Environmental Project (SEP) agreement to install air filtration systems at one or more schools in an Environmental Justice community in the South Coast region. Both parties have requested SCAQMD act as the SEP Implementer for this project, which must be completed by January 2019.

IQAir North America was previously selected through two separate competitive bid processes in 2011 and 2013 for the TraPac and AB 1318 air filtration projects, respectively. They were also the only qualified manufacturer of high performance filters and stand-alone units to meet the performance standards in SCAQMD's 2009 air filtration pilot study as well as through a national testing opportunity conducted by the University of California Riverside/College of Engineering-Center for Environmental Research & Technology at Sunnyslope Elementary School in 2010. To date, through its contractor IQAir, SCAQMD has installed air filtration systems at 71 schools and community centers. Performance standards from SCAQMD's air filtration pilot study include an overall removal efficiency of at least 85 percent for ultrafine PM and black carbon, low pressure drop for panel filters, no ozone generation and a noise level below 45 decibels for stand-alone units.

Proposal

CARB staff have requested that selected schools receiving air filtration systems be in Environmental Justice communities close to intermodal rail facilities or other sources of diesel PM as well as project completion by January 2019. Staff will also utilize an existing Memorandum of Agreement (MOA) with the Los Angeles Unified School District, providing access to any schools in that district, as well as execute any necessary MOAs with other school districts to provide site access to schools.

The proposed schedule for installation of air filtration systems in one or more schools in Environmental Justice communities is as follows:

Date	Event
March 2017	Board Approval
March 2017	Anticipated Contract Award
March-April 2017	Selection of School(s), Site Assessments
April-September 2017	Installation
September 2017	Final Report

These actions are to create the Air Filtration Fund (75); recognize up to \$625,000 from BNSF into the Air Filtration Fund (75); and transfer up to \$625,000 as a temporary loan from the Clean Fuels Fund (31) to the Air Filtration Fund (75).

Finally, these actions are to also execute an agreement with BNSF for SCAQMD to act as the SEP Implementer for this project and execute a contract with IQAir North America for installation of air filtration systems as well as reimburse administrative costs.

Sole Source Justification

Section VIII. B. 2 of the Procurement Policy and Procedure identifies four major provisions under which a sole source award may be justified. This request for a sole source award is made under provision B.2.c(1): The desired services are available from only the sole-source based upon the unique experience and capabilities of the proposed contractor or contractor team. IQAir is the only manufacturer of high performance panel filters and stand-alone units identified by SCAQMD and CARB Research Division staff that meet the performance standards in SCAQMD’s 2009 air filtration pilot study. Staff has also consulted with CARB Research Division staff to confirm that no new manufacturers of air filtration technologies that meet or exceed the performance standards in the pilot study have been identified since the last RFP process in 2013.

Benefits to SCAQMD

This project will reduce children’s exposure to criteria and toxic pollutants and ultrafine PM. Health studies have determined that fine and ultrafine PM, including diesel PM, present the greatest air pollution health risk to sensitive receptors in Environmental Justice communities in Southern California.

Resource Impacts

Upon receipt, up to \$625,000 from the SEP revenue will be recognized into the Air Filtration Fund (75). Until receipt, up to \$625,000 from the Clean Fuels Fund (31) will be used as a temporary loan. Of the \$625,000 SEP revenue, the contract with IQAir North America to install air filtration systems will not exceed \$593,750 and reimbursement of administrative costs will not exceed \$31,250.

Agenda Item #3

Patricia Kwon

Create Special Revenue Fund, Recognize and Transfer Funds, Execute Agreement for Installation of Air Filtration Systems, Execute Contract and Reimburse General Fund for Administrative Costs

Background

- CARB and BNSF executing Supplemental Environmental Project (SEP) to install air filtration systems - \$625,000
- SCAQMD
 - Experience with previous projects
 - Board-approved contractor



Background (Contd.)

- SCAQMD selected IQAir as air filtration contractor
 - Two competitive bid processes (TraPac, AB1318)
 - National testing opportunity
- SCAQMD/CARB staff not aware of another technology meeting performance standards of pilot study

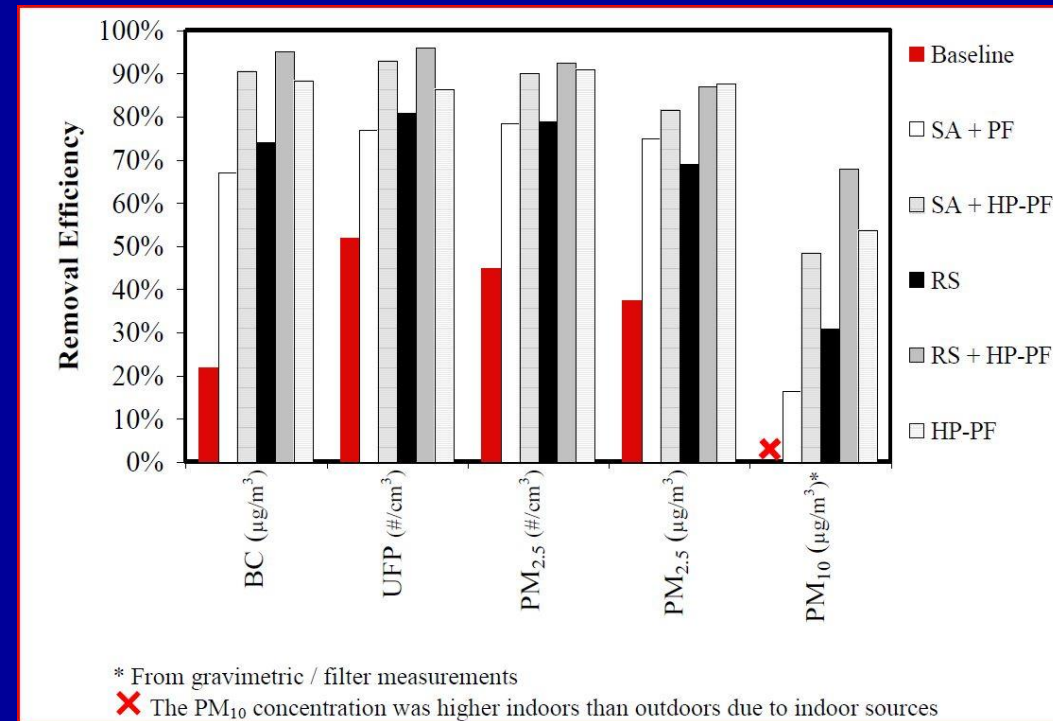

Air Filtration Technologies

- High performance panel filters + stand alone units
- 90% overall removal efficiency ultrafine PM, black carbon
- Noise level below 45 dB(A) for stand-alone units (no interference with classroom learning)



Proposal

- SCAQMD as SEP implementer – MOA with BNSF
- Identify school(s) within EJ areas
- Work with contractor
 - Installation
 - Operational/maintenance needs, including replacement filters

Proposed Schedule

Date	Task
March 2017	Board approval
March 2017	Contract execution
March – Apr 2017	School selection, site assessments
Apr – Sept 2017	Installation
Sept 2017	Final report

Recommended Actions

- Create Air Filtration Fund (75)
- Recognize, upon receipt, \$625,000 from BNSF into Fund 75
- Transfer up to \$625,000 as temporary loan from Clean Fuels Fund (31) into Fund 75
- Authorize Executive Officer to execute agreement with BNSF for SCAQMD to act as SEP implementer to install air filtration systems

Recommended Actions

- Authorize Chairman to execute contract with IQAir for installation of air filtration systems in an amount not to exceed \$593,750 from Fund 75
- Reimburse the General Fund from the Air Filtration Fund (75) for administrative costs up to \$31,250 as needed to implement the air filtration project

[Go to SLIDES](#)

DRAFT
Technology Committee Agenda #4

BOARD MEETING DATE: March 3, 2017

AGENDA NO.

PROPOSAL: Transfer Funds, Execute Contract to Develop and Demonstrate Vessel Performance Management Software and Equipment, and Amend Award 

SYNOPSIS: The California State University Maritime Academy proposes to demonstrate a technology capable of harvesting high altitude wind energy while employing a vessel performance optimization system. The first two phases of the project includes the design and installation of the performance management software and equipment followed by demonstration of the equipment with performance evaluation of its fuel and emissions reductions capabilities. Staff proposes to cost-share phase 2 of this project with the California State University Maritime Academy, Maritime Administration and Bay Area AQMD. These actions are to transfer \$50,086 from the BP ARCO Settlement Projects Fund (46) into the Clean Fuels Fund (31), and execute a contract with the California State University Maritime Academy for the design and demonstration of vessel performance management software and equipment in an amount not to exceed \$50,086 from the Clean Fuels Fund (31). Finally, this action is to amend a contractor's name from Ricardo Solutions to Ricardo, Inc., for a prior award.

COMMITTEE: Technology, February 17, 2017; Recommended for Approval

RECOMMENDED ACTIONS:

1. Transfer \$50,086 from the BP ARCO Settlement Projects Fund (46) to the Clean Fuels Fund (31);
2. Authorize the Chairman to execute a contract with the California State University Maritime Academy for the design and demonstration of vessel performance management software and equipment in an amount not to exceed \$50,086 from the Clean Fuels Fund (31); and

3. Amend a contractor's name from Ricardo Solutions to Ricardo, Inc., for a previous award for technical assistance for an unchanged amount of \$50,000 from the Clean Fuels Fund (31).

Wayne Natri
Executive Officer

MMM:FM:NB

Background

Ocean going vessels (OGVs) are very large vessels designed for deep water navigation. OGVs include large cargo vessels such as container vessels, tankers and bulk and car carriers, as well as passenger cruise vessels. These vessels transport containerized cargo including bulk items such as vehicles, cement and coke, liquids such as oil and petrochemicals, and passengers. OGVs travel internationally and may be registered by the U.S. Coast Guard (U.S.-flagged) or under the flag of another country (foreign-flagged). The majority of vessels that visit California ports are foreign-flagged vessels.

The Ports of Los Angeles and Long Beach (San Pedro Bay Ports) have jointly developed the San Pedro Bay Ports Clean Air Action Plan (CAAP), designed to reduce the emissions from a variety of port sources, including OGVs. The Plan encourages use of cleaner technology and practices in advance of regulations. Additional technologies and innovations are necessary to further enhance efficiencies and reduce emissions. This goal is consistent with CARB's Mobile Source Strategy as well as the Draft 2016 Air Quality Management Plan.

Proposal

The California State University Maritime Academy (Cal Maritime) is uniquely positioned to help maritime innovators and entrepreneurs test the technical merits, feasibility and scalability of their ideas. One such project is the SkySails project, which is being conducted in collaboration with research partners--the Adept Group, Inc., in Los Angeles, the College of Engineering/Center for Environmental Research and Technology (CE-CERT) at the University of California Riverside, and the Federal Maritime Administration (MARAD). The SkySails project seeks to validate the harvesting of high altitude wind energy (through the installation of a kite propulsion system and a vessel performance optimizing system on the Cal Maritime training ship) to provide supplemental green power to commercial shipping, as well as to objectively determine the extent such systems can lower criteria pollutants emissions, CO2 releases and fuel consumption.

The proposed project includes a science-based and peer-reviewed protocol to test, monitor, analyze and report the project's findings. Commercial vessels travelling

regularly through Northern California waters have been approached to partner in this project. The overall project has the following four phases:

1. Plan for Capturing Baseline Indicators (1st year Cruise - Summer 2016) - Completed
Preliminary efforts included upgrades to the vessels fuel consumption metering and exhaust gas flow sensors to back up the emissions profiling. This emissions profiling was conducted by CE-CERT, establishing a baseline for GHGs and other constituents, including particulates associated with diesel engine exhaust. All future projects involving exhaust gas emissions and fuel efficiency will utilize these measurements and metrics to gauge effects.
2. The Vessel Performance Manager (V-PER) (2nd Year Cruise – Summer 2017)
The installation of this system is designed to enable smarter decisions while at sea, by providing real-time data point-related fuel consumption, engine performance along with external information, such as weather, to optimize ship speed, route plan, trim and energy management.
3. The Kite Phase (3rd year Cruise – Summer 2018)
The SkySail kite will be installed, with a need to re-engineer the bulkheads of the ship to accept the stress that will be placed on them by the kite. This will require the selection of an engineering firm to reconfigure the ship.
4. The Analysis and Dissemination Phase (Fall 2018– Winter 2019)
Upon completion of the testing, results will be reported to project partners and Cal Maritime industry leaders. Both publications and presentations will be used to disseminate the findings.

The goals for this project are as follows:

1. Demonstrate and quantify lower fuel use by the Training Ship Golden Bear (TSGB) on its summer cruises.
2. Help to improve air quality in coastal communities.
3. Encourage the development and growth of the environmental sustainability industry.
4. Inspire the development of future maritime and port leaders as better stewards of the environment, and
5. Deliver final reports including publishable papers and presentations to key stakeholders.

These actions are to transfer \$50,086 from the BP ARCO Settlement Projects Fund (46) into the Clean Fuels Fund (31) and execute a contract with the California State University Maritime Academy for the design and demonstration of vessel performance management software and equipment in an amount not to exceed \$50,086 from the Clean Fuels Fund (31). The requested SCAQMD funds are to

support Phase 2 of the project and further enable Phases 3 and 4 to further increase the emissions reduction potential.

Finally, at the June 3, 2016 meeting, the Board authorized the Chairman to execute a contract for technical assistance with Ricardo Solutions in an amount not to exceed \$50,000 from the Clean Fuels Fund (31). In preparing the contract, it was determined that the contractor’s name should have been listed as Ricardo, Inc. This action is to amend the contractor’s name from Ricardo Solutions to Ricardo, Inc., in order to execute the contract.

Sole Source Justification

Section VIII.B.2 of the Procurement Policy and Procedure identifies four major provisions under which a sole source award may be justified. This request for sole source award is made under provision B.2.d.: Other circumstances exist which in the determination of the Executive Officer require such waiver in the best interest of the SCAQMD. Specifically, these circumstances are B.2.d.(1): Project involving cost-sharing by multiple sponsors, including the Bay Area AQMD and MARAD to implement Phase 2 of the overall project.

Benefits to SCAQMD

The South Coast Air Basin is classified as an “extreme” nonattainment area for ozone under the federal Clean Air Act. A wide-scale deployment of low NOx technologies, including emissions from OGVs, is a critical step toward achieving the air quality standards with considerable public health benefits for our region. Locally, this project has the potential to lower NOx and diesel PM emissions and demonstrate potential pathways to increase efficiencies from OGVs.

Resource Impacts

SCAQMD’s total cost-share for Phase 2 of the project with Cal Maritime will not exceed \$50,086 using funds from the BP ARCO Settlement Projects Fund (46) transferred into the Clean Fuels Fund (31). Total project costs are \$212,347. Project development costs for Phase 2 are as follows:

Project Development Costs

Funding Sources	Funding Amount		Total	Percent
	Cash	In-Kind		
Bay Area AQMD	\$50,086	\$16,432	\$66,518	31%
MARAD	\$79,311	\$0	\$79,311	38%
SCAQMD (<i>requested</i>)	\$50,086	\$16,432	\$66,518	31%
Total	\$179,483	\$32,864	\$212,347	100%

Sufficient funds are available from the BP ARCO Settlement Projects Fund (46). The Clean Fuels Fund (31) is established as a special revenue fund resulting from the state-mandated Clean Fuels Program. The Clean Fuels Program, under Health and Safety Code Sections 40448.5 and 40512 and Vehicle Code Section 9250.11, establishes mechanisms to collect revenues from mobile sources to support projects to increase the utilization of clean fuels, including the development of the necessary advanced enabling technologies. Funds collected from motor vehicles are restricted, by statute, to be used for projects and program activities related to mobile sources that support the objectives of the Clean Fuels Program.

Agenda Item #4

Naveen Berry

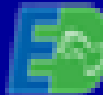
Transfer Funds, Execute Contract to Develop
and Demonstrate Vessel Performance
Management Software and Equipment and
Amend Award 

Background

- Reduction in emissions related to shipping part of AQMP/CARB Mobile Source Strategy
- Incentives available from Ports for low emission ships
- Technologies available to reduce emissions and increase efficiencies



Proposal

- California State University Maritime Academy (Cal Maritime)



Four-phase project on the Golden Bear Ship

1. Plan for capturing baseline indicators (1st year cruise - Summer 2016) - completed
2. The Vessel Performance Manager (V-PER) (2nd year cruise – summer 2017)
3. The Kite Phase (3rd year cruise – summer 2018)
4. The Analysis and Dissemination Phase (fall 2018–winter 2019)

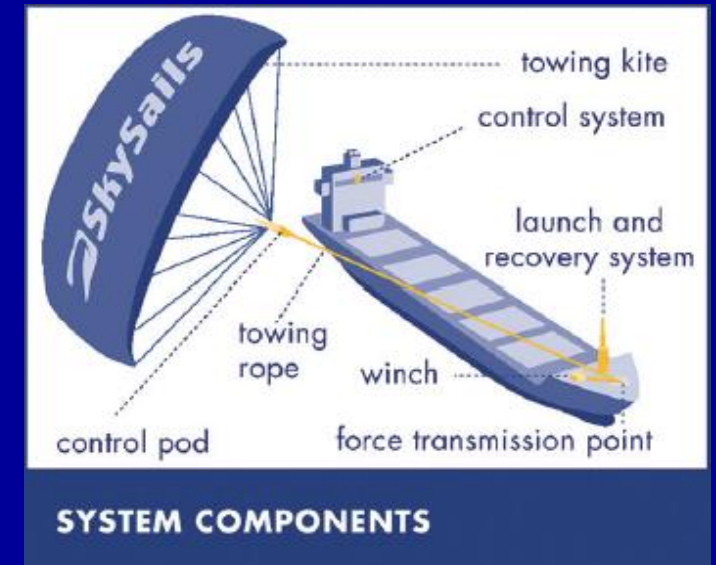

V-PER

- Real-time ship operating data
- Hull/propeller condition
- Optimized fuel consumption (can save up to 20%)
- Properly scheduled and timely ship maintenance
- Optimized ship trip



Proposed Project Cost

Funding Sources	Funding Amount		Total	Percent
	Cash	In-Kind		
Bay Area AQMD	\$50,086	\$16,432	\$66,518	31%
MARAD	\$79,311	\$0	\$79,311	38%
SCAQMD (<i>requested</i>)	\$50,086	\$16,432	\$66,518	31%
Total	\$179,483	\$32,864	\$212,347	100%

Recommended Actions

- Transfer \$50,086 from the BP ARCO Settlement Projects Fund (46) into the Clean Fuels Fund (31) and execute a contract with Cal Maritime to design and demonstrate vessel performance management software and equipment in an amount not to exceed \$50,086 from the Clean Fuels Fund (31)
- Amend award for technical assistance from Ricardo Solutions to Ricardo, Inc. – No Cost Impact

[Go to SLIDES](#)

DRAFT
Technology Committee Agenda #5

BOARD MEETING DATE: March 3, 2017

AGENDA NO. xx

PROPOSAL: Approve and Adopt Technology Advancement Office Clean Fuels Program 2016 Annual Report and 2017 Plan Update and Resolution, and Receive and File and Approve and Adopt Revised Membership of Technology Advancement and Clean Fuels Advisory Groups 

SYNOPSIS: Each year by March 31, the Technology Advancement Office must submit to the California Legislative Analyst an approved Annual Report for the past year and a Plan Update for the current calendar year. Staff has reviewed the Clean Fuels Program with the Clean Fuels Advisory Group, the Technology Advancement Advisory Group and other technical experts. Additionally, the 2017 Clean Fuels Program Draft Plan Update was presented to the Technology Committee for review and comment at its October 21, 2016 meeting. This action is to approve and adopt the final Technology Advancement Clean Fuels Program Annual Report for 2016 and 2017 Plan Update as well as the Resolution finding that proposed projects do not duplicate any past or present programs. This action is to also receive and file membership changes to the Technology Advancement Advisory Group and approve and adopt membership changes to the SB 98 Clean Fuels Advisory Group.

COMMITTEE: Technology, October 21, 2016 and February 17, 2017;
Recommended for Approval

RECOMMENDED ACTIONS:

1. Adopt the attached Technology Advancement Office Clean Fuels Program Plan Update for 2017 and include it in the SCAQMD's Clean Fuels Program
2. Approve the attached Technology Advancement Office Annual Report for 2016;
3. Approve the attached Resolution finding that the update Technology Advancement Office Clean Fuels Program Plan Update for 2017 and its proposed projects do not duplicate any past or present programs of specified organizations;
4. Receive and file membership changes to the Technology Advancement Advisory Group; and

5. Approve and adopt membership changes to the SB 98 Clean Fuels Advisory Group.

Wayne Natri
Executive Officer

MMM:FM:NB:LCM:DAH

Background

Achieving federal and state ambient air quality standards in the South Coast Air Basin will require emission reductions from both mobile and stationary sources beyond those available from current technologies. The Draft 2016 Air Quality Management Plan (AQMP) measures rely on a mix of currently available technologies as well as the expedited development and commercialization of lower-emitting mobile and stationary advanced technologies in the Basin to achieve these standards. The 2016 AQMP projects that a 45 percent reduction in NO_x is required by 2023 and an additional 55 percent reduction by 2031, the majority of which must come from mobile sources (both on- and off-road), requiring widespread deployment of current clean air technologies as well as further commercialization of advanced technologies. The Technology Advancement Office (TAO) Clean Fuels Program, more than ever before, is an integral part of this effort, and it must foster and accelerate advancement of transformative transportation and off-road technologies, with an emphasis on commercialization of zero and near-zero emission vehicle and fuel technologies, especially given the region's thriving goods movement industry.

The Clean Fuels Program, first initiated in 1988 along with establishment of TAO, is implemented as a public-private partnership in conjunction with private industry, technology developers, academic institutions, research institutions and government agencies. This public-private partnership has enabled the SCAQMD to historically leverage public funds with outside investment in a ratio of about \$4 of outside funding to every dollar of Clean Fuels funding. While TAO aggressively seeks to leverage funds to accomplish more with every dollar, it also strives to act as a leader in technology development and commercialization in an effort to accelerate the reduction of criteria pollutants.

Health and Safety Code (H&SC) Section 40448.5.1 requires that the SCAQMD adopt a plan that describes the expected cost and benefits of proposed projects prior to any Clean Fuels Program expenditure and find that the proposed projects do not duplicate programs of other organizations specified in the H&SC provision. In 1999, SB 98 amended this provision by requiring annual updates to this Plan as well as a 30-day public notice to specified interested parties and the public prior to the annual public hearing at which the Governing Board takes action on the Clean Fuels Program. SB 98 also requires the preparation of an annual report with specified contents. This annual

report requires review by an advisory group and approval by the Governing Board, prior to submittal to specified offices of the California Legislature each year. This legislation also specifies the make-up of the 13-member Clean Fuels Advisory Group (CFAG) and its primary responsibilities to make recommendations regarding the most cost-effective projects that advance and implement clean fuels technology and improve public health. The membership of the CFAG was initially approved by the Governing Board in September 1999. Changes to the composition are reviewed by the Board's Technology Committee on an as-needed basis, subject to full Board approval as required by the charter. Prior to formation of the CFAG, the SCAQMD had formed the Technology Advancement Advisory Group (TAAG) to review and assess the Clean Fuels Program. The charter and membership of the TAAG was revisited in 1999 with formation of the CFAG so their function would complement each other. The TAAG's charter specifies membership changes must be approved by the Governing Board's Technology Committee, and in fact membership changes to the TAAG were approved by the Technology Committee last year in conjunction with approval of the prior report.

Proposal

This package includes an adoption resolution (Attachment A) and one combined document comprising the TAO Clean Fuels Program 2016 Annual Report and 2017 Plan Update (Attachment B). This action is for the Governing Board to approve and adopt the TAO Clean Fuels Program Annual Report and Plan Update. Additionally, as part of the Governing Board's consideration of the Plan Update, the Governing Board must make a finding that the update to the TAO Clean Fuels Program and its proposed projects do not duplicate any past or present programs of specified organizations. The review process by the two advisory groups helps ensure that SCAQMD efforts do not duplicate projects. The advisory groups provide feedback to staff on the documents during in-person biannual meetings and through subsequent correspondence. The advisors are all experts in different fields and are members of national laboratories, state or federal agencies and/or academia. Staff diligently monitors specific technologies through efforts at state and federal collaboratives, partnerships and industrial coalitions. Finally, staff also invites other technical experts to review the Annual Report and Plan Update. Through this wide network, staff is confident there is no duplication of technology projects represented in the Plan Update as required in the H&SC. Attachment A is an adoption resolution making such a finding.

Clean Fuels Program Annual Report 2016

The Annual Report covers projects and progress of the Program for Calendar Year (CY) 2016. As discussed earlier, this report addresses all of the requirements specified in H&SC 40448.5.1(d). Specifically, the report includes the following required elements:

- A description of the core technologies that the SCAQMD considers critical to ensure attainment and/or maintenance of ambient air quality standards and a description of the efforts made to overcome commercialization barriers;

- An analysis of the impact of the TAO's Clean Fuels Program on the private sector and on research, development and commercialization efforts by major automobile and energy firms, as determined by SCAQMD staff;
- A description of projects funded by the SCAQMD, including a list of recipients, subcontractors, cofunders, matching state or federal funds and expected and actual results of each project advancing and implementing clean fuels technology and improving public health;
- The title and purpose of all projects undertaken pursuant to the Clean Fuels Program, the names of the contractors and subcontractors involved in each project, and the amount of money expended for each project;
- A summary of the progress made toward the goals of the Clean Fuels Program; and
- Funding priorities identified for the next year and relevant audit information for previous, current and future years covered by the report.

During CY 2016, the Clean Fuels Program executed 60 new projects or studies and modified 6 continuing contracts adding additional dollars to sponsor research, development, demonstration and deployment projects of alternative fuel and clean fuel technologies. The SCAQMD's contribution to these projects was approximately \$21.8 million, with total project costs of slightly more than \$198 million that includes funding from other governmental agencies, private sector, academia and research institutions. The \$21.8 million includes \$3.4 million recognized into the Clean Fuels Fund as pass-through funds from project partners. These projects address a wide range of air quality issues with a diverse mix of advanced technologies. Figure 1 shows the distribution of funding committed from the Clean Fuels Program through executed agreements in 2016. It should be noted that the executed agreements typically lag the Governing Board awards due to the time necessary to negotiate contracts. During this phase, project awards may be reduced in scope, encounter delays in execution, or may not be contracted at all due to unforeseen difficulties following Governing Board approval. As such, the funding distribution represents a "snapshot-in-time" of the Clean Fuels Program for the calendar year.

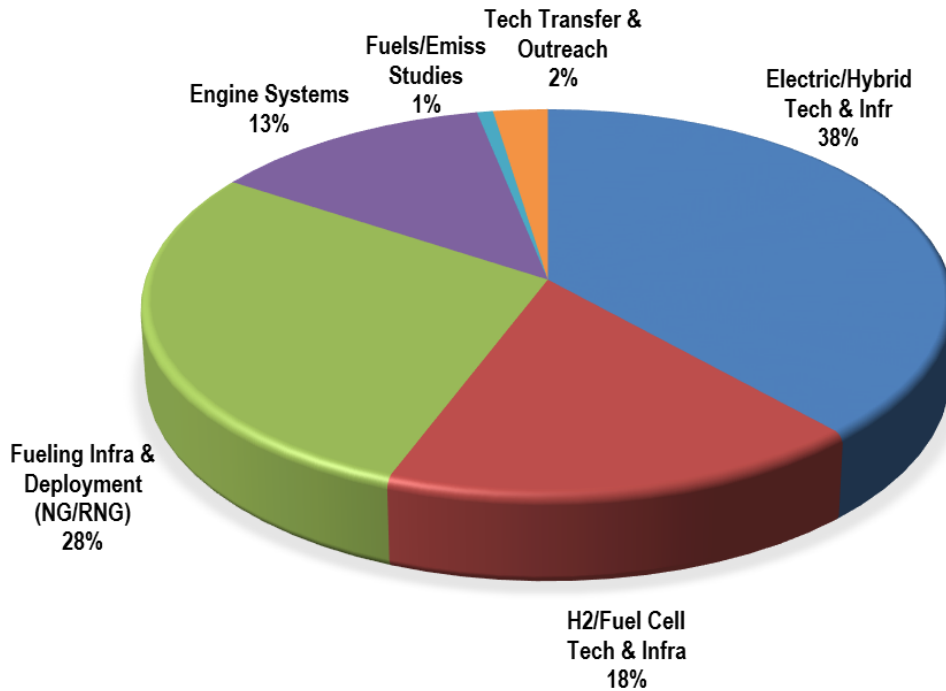

Figure 1: Distribution of Clean Fuels Program Funds in CY 2016 (\$21.8 Million)

During CY 2016, the SCAQMD supported a variety of projects and technologies, ranging from near-term to long-term research, development, demonstration and deployment activities. This “technology portfolio” strategy provides the SCAQMD the ability and flexibility to leverage state and federal funding while also addressing the specific needs of the South Coast Air Basin. Projects executed in CY 2016 included significant hydrogen/fuel cell projects to develop and demonstrate both medium- and heavy-duty vehicles in the goods movement industry; continued development and demonstration of electric and hybrid technologies and infrastructure with an emphasis on zero emission goods movement technologies, most notably CARB’s \$23 million California Climate Initiative award for zero emission drayage trucks; development and demonstration of heavy-duty natural gas engines and vehicles including larger-scale natural gas engines; and natural gas and renewable natural gas production projects as part of broader-scale fueling infrastructure and deployment efforts. The significant project scopes of a few of the key contracts executed in 2016 resulted in leveraging \$9 for every \$1 of Clean Fuels funding, whereas typical leveraging is \$3-\$4 for every \$1 in Clean Fuels funding.

In addition to the new projects, 32 research, development and demonstration projects or studies and 11 technology assessment and transfer projects were completed in CY 2016. Summaries for each of the technical projects are provided in Appendix C of the Annual Report.

The Clean Fuels Program in CY 2016 continued to leverage other outside opportunities, with the SCAQMD securing new awards totaling \$48.9 million from federal, state and local funding for projects that will be included in the Clean Fuels Program or which align well with and are complementary to the Clean Fuels Program. Staff will continue to look for and aggressively pursue applicable funding opportunities that may focus on greenhouse gas emissions reductions, energy efficiency and reduction in petroleum usage, while remaining committed to acting as a leader in developing advanced technologies that lower criteria pollutants. Leveraging dollars and applying for funds is more important than ever given the magnitude of required funding identified in the 2016 AQMP to achieve federal ozone air quality standards.

Clean Fuels Program Plan Update 2017

Every year, TAO staff re-evaluates the Clean Fuels Program to develop a Plan Update which essentially serves to re-calibrate the technical direction of the Program. The attached Plan Update for the Clean Fuels Program identifies potential projects to be considered for funding during 2017 and beyond. The proposed projects reflect promising low-, near-zero or zero emission technologies and applications that are emerging in the different source categories. This Plan Update includes a number of proposed projects, not all of which are expected to be funded in the current calendar year given the available budget. Some of the proposed projects for 2017 include but are not limited to: 1) development and demonstration of large-scale hydrogen refueling facilities; 2) development and demonstration of ultra-low emission diesel larger displacement engines; 3) development and demonstration of zero emission heavy-duty vehicles; 4) development, demonstration and deployment of advanced natural gas engines and zero emission technologies for high horsepower applications; and 5) development and demonstration of alternative fuel production and infrastructure, especially with renewable fuels. Projects not funded in 2017 may be considered for funding in future years.

In addition to identifying proposed projects to be considered for funding, this Plan Update confirms nine key technical areas of highest priority to the SCAQMD. These high priority areas are listed below based on the proposed funding distribution shown in Figure 2:

- Hydrogen and Mobile Fuel Cell Technologies and Infrastructure (especially large-scale refueling facilities)
- Electric and Hybrid Vehicle Technologies and Related Infrastructure (emphasizing electric and hybrid electric trucks and container transport technologies with zero-emission operation)
- Engine Systems (emphasizing heavy-duty alternative and renewable fuel engines for truck and rail applications)
- Fueling Infrastructure and Deployment (predominantly natural gas and renewable fuels)

- Fuels and Emission Studies
- Stationary Clean Fuels Technologies (including renewables)
- Technology Assessment and Transfer and Outreach
- Emission Control Technologies
- Health Impacts Studies

It should be noted that these priorities represent the areas where SCAQMD funding is thought to have the greatest impact. In keeping with the diverse and flexible “technology portfolio” approach, however, these priorities may shift during the year to: (1) capture opportunities such as cost-sharing by the state government, the federal government or other entities, (2) address specific technology issues which affect residents within the SCAQMD jurisdiction; (3) incorporate findings from recent studies; or (4) further accelerate technology development, commercialization or market acceptance of promising technologies.

These technical priorities will necessarily be balanced by funding availability and the availability of qualified projects. Revenues from several sources support SCAQMD’s Technology Advancement program. The principal revenue source is the Clean Fuels Program which, under H&SC Section 40448.5 and Vehicle Code Section 9250.11, establishes mechanisms to collect revenues from mobile and stationary sources to support the Program’s objectives, albeit with constraints on the use of the funds. Grants and cost-sharing revenue contracts from various government agencies, such as CARB, CEC, NREL and the U.S. Departments of Energy and Transportation, also support technology advancement efforts.

The Plan Update is the result of a comprehensive planning and review process. This process included consideration of the 2012 and 2016 AQMP control measures as well as CARB’s Mobile Source Strategies and the Sustainable Freight Action Plan. It also incorporates coordination activities involving outside organizations including consideration of federal, state and local activities and proposed integrated solutions that capture the co-benefits of reduced GHG emissions and criteria pollutants. As part of this process, staff hosted two meetings in September 2016 and January 2017 to solicit input from the CFAG, TAAG and other technical experts. During these meetings, the participants reviewed the current Technology Advancement projects and discussed near-term and long-term technologies as potential projects. A Medium- and Heavy-Duty Innovators Roundtable to discuss existing and near commercial technologies and potential implementation pathways was convened in May 2016, as well as a zero and near-zero emissions heavy-duty truck site visit and discussion with EPA, CARB and the Ports in October 2016. Additionally, staff attended meetings or workshops with CARB, CEC, the California Fuel Cell Partnership, the California Plug-in Electric Vehicle Collaborative, California Hydrogen Business Council, and other entities to solicit and incorporate technical areas for potential leveraged funding and project coordination.

Based on communications with the organizations specified in H&SC Section 40448.5.1 and review of their programs, the projects proposed in this Plan Update do not appear to duplicate any past or present projects. As each individual project is recommended to the Governing Board for funding, staff will continue to coordinate with these organizations to ensure that duplication is avoided and ensure optimal expenditure of Clean Fuels Program funds.

Staff presented the Draft 2017 Clean Fuels Program Plan Update to the Technology Committee on October 21, 2016, and the changes in funding priority requested by the Technology Committee are reflected in the revised Plan Update. These changes were to increase funding in the engine systems category while decreasing the amount in the electric and hybrid technologies and infrastructure category due to the recent CARB drayage truck award. Figure 2 graphically depicts the potential distribution of Clean Fuels Program funds, based on projected program costs of \$16.5 million, for the nine project areas discussed above.

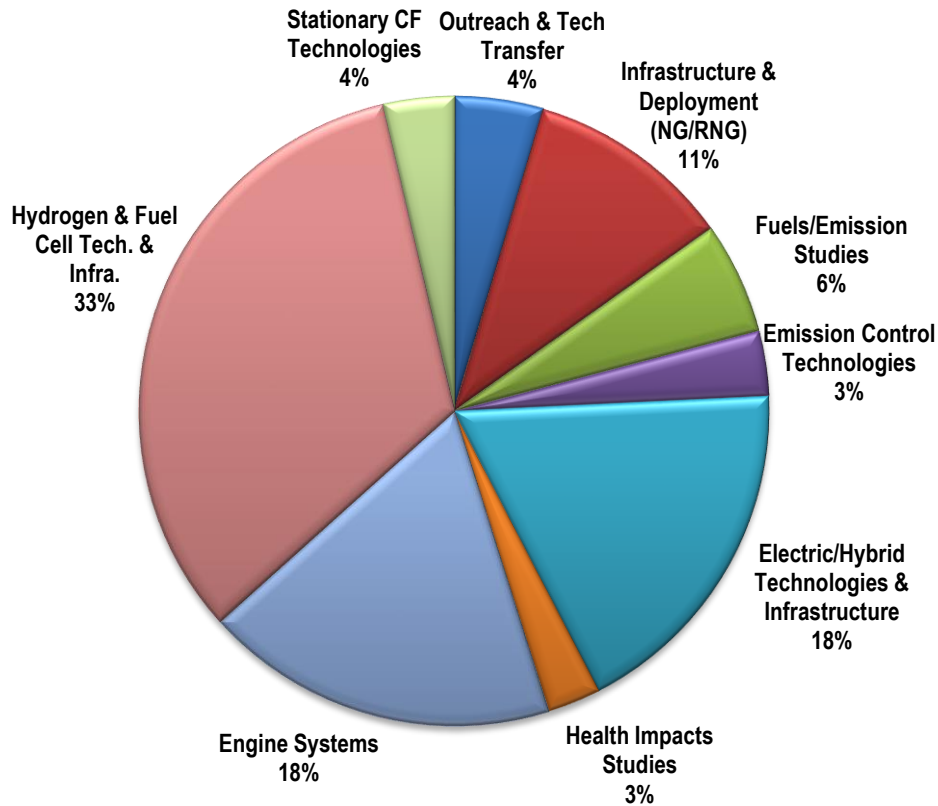

Figure 2: Projected Cost Distribution for Potential Projects in 2017 (\$16.5 million)

The expected actual program expenditures for 2017 will be much less than the total projected program cost since not all projects will materialize. The target allocations are based on balancing technology priorities, technical challenges and opportunities discussed previously and near-term versus long-term benefits with the constraints on

available Clean Fuels funding. Specific contract awards throughout 2017 will be based on this proposed allocation, the quality of proposals received and evaluation of projects against standardized criteria and, ultimately, the Governing Board's approval. At that time, additional details will be provided about the technology, its application, the specific scope of work, the project team capabilities and the project cost-sharing.

H&SC Section 40448.5.1 requires the Board approve the Clean Fuels Annual Report for 2016 and adopt the Clean Fuels Plan Update for 2017 as well as find that the proposed projects do not duplicate programs of other organizations specified in the H&SC provision. And as required, the Annual Report and Plan Update have been reviewed by the SB 98 Clean Fuels Advisory Group.

Attachments

- A. Resolution
- B. Qualifications and Expertise of Proposed New Advisory Group Members
- C. TAO Clean Fuels Program 2016 Annual Report and 2017 Plan Update

ATTACHMENT A

RESOLUTION NO. 17-

A Resolution of the Governing Board of the South Coast Air Quality Management District (SCAQMD) approving the Technology Advancement Office Clean Fuels Program Annual Report for 2016 and adopting the Clean Fuels Program Plan Update for 2017.

WHEREAS, the Board initiated a Clean Fuels Program in 1988 to expedite the demonstration and commercialization of advanced low emission and zero emission technologies and clean fuels; and,

WHEREAS, Health and Safety Code Sections 40404 and 40448.5 require the SCAQMD to coordinate and manage a Clean Fuels Program to accelerate the utilization of clean-burning fuels within the South Coast Air Basin; and,

WHEREAS, Health and Safety Code Section 40512 and Vehicle Code Section 9250.11 authorize funding for the SCAQMD Clean Fuels Program; and,

WHEREAS, SB 98 (Alarcon), chaptered into state law on June 8, 1999, extended the funding authority for the Clean Fuels Program and added administrative provisions under Health and Safety Code Section 40448.5.1 regarding program planning and reporting, including:

- Providing notice to interested parties and the public at least 30 days prior to the annual public hearing at which the south coast district board or a committee of the board takes action to approve the clean-burning fuels program.
- Consulting with the SB 98 Clean Fuels Advisory Group regarding approval of the required annual report. The results of that consultation shall be provided to the south coast district board prior to its approval of the report.
- Submitting the Clean Fuels Program annual report to the office of the Legislative Analyst and to the committees of the Legislature responsible for improving air quality on or before March 31 of each year that the clean-burning fuels program is in operation; and

WHEREAS, SB 1646 (Padilla), chaptered into state law on September 30, 2008, reauthorized the funding authority for the Clean Fuels Program, removed the sunset of January 1, 2010, and reinstated the five percent administrative cap; and,

WHEREAS, the Technology Advancement Office Clean Fuels Program Plan Update has been reviewed and commented on by both the Technology Advancement Advisory Group and the SB 98 Clean Fuels Advisory Group; and,

WHEREAS, Health and Safety Code Section 40448.5.1 requires that the SCAQMD coordinate and ensure non-duplication of clean fuels-related projects with specified organizations, including the: CARB, CEC, California air quality management districts or air pollution control districts, a public transit district or authority within the geographic jurisdiction of the south coast district, San Diego Transit Corporation, North County Transit District, Sacramento Regional Transit District, Alameda-Contra Costa Transit District, San Francisco Bay Area Rapid Transit District, Santa Barbara Metropolitan Transit District, Los Angeles Department of Water and Power, Sacramento Municipal Utility District, Pacific Gas and Electric Company, Southern California Gas Company, Southern California Edison Company, San Diego Gas and Electric Company, or the Office of Mobile Sources within the U.S. Environmental Protection Agency; and

WHEREAS, based on communications with the organizations specified in Health and Safety Code Section 40448.5.1 and review of their programs, the proposed program and projects included in the Technology Advancement Office Clean Fuels Program Plan Update do not duplicate any other past or present program or project funded by those organizations; and,

WHEREAS, notice has been provided to interested parties and the public at least 30 days prior to the annual public hearing at which the south coast district board is to consider approving the clean-burning fuels program; and,

WHEREAS, the SB 98 Clean Fuels Advisory Group has reviewed the Technology Advancement Office Annual Report.

NOW, THEREFORE, BE IT RESOLVED, that the Board finds the Technology Advancement Office Clean Fuels Program Plan Update does not duplicate any past or present programs or projects funded by the above-specified organizations.

BE IT FURTHER RESOLVED, that the Board approves the Technology Advancement Office Clean Fuels Program Annual Report for 2016.

BE IT FURTHER RESOLVED, that the Board adopts the Technology Advancement Office Clean Fuels Program Plan Update for 2017.

BE IT FURTHER RESOLVED, that the Board hereby directs staff to forward the Technology Advancement Office Clean Fuels Program Annual Report 2016 and Plan Update 2017 to the California Legislature and the Legislative Analyst.

Dated:

Denise Garzaro, Clerk of the Board

ATTACHMENT B
Qualifications and Expertise of Proposed New Advisory Group Members

SB 98 Clean Fuels Advisory Group*

<p>John Faust, PhD., Cal-EPA</p>	<p>Dr. John Faust, Branch Chief of the Air, Community and Environmental Research Branch, at the Office of Environmental Health Hazard Assessment, Cal/EPA, located in Oakland, California, has since 2004, managed Cal/EPA’s efforts, under its Environmental Justice Action Plan, to introduce consideration of the cumulative impact of environmental pollutants into decision-making. This work has included evaluating scientific data on health and exposure disparities and population vulnerability, particularly in low-income or minority populations. Dr. Faust has provided technical expertise to the office in the areas of toxicology, carcinogenic mode of action, dose-response assessment, and risk assessment. Other work has involved identification of new carcinogenic hazards, establishing cancer potencies and standards for contaminants in drinking water. He is a graduate of Virginia Tech (B.S., Biochemistry, 1985) and Duke University (Ph.D. Pharmacology/Toxicology, 1990)</p>
--------------------------------------	---

**The charter of the CFAG requires membership changes to be approved by the full SCAQMD Board.*

Technology Advancement Advisory Group**

<p>David Pettit NRDC</p>	<p>David Pettit, Senior Attorney at the Natural Resources Defense Council, is an experienced civil litigator in the state and federal trial and appellate courts. For 17 years, David was a shareholder in Caldwell, Leslie, Newcombe & Pettit, a Los Angeles law firm specializing in complex civil litigation. Prior to that, David was an associate at O’Melveny & Myers, a deputy city attorney for the City of Santa Monica, and a staff attorney with San Fernando Valley Neighborhood Legal Services. David also is active in the legal profession. He has served as a Judge Pro Tem in the Los Angeles Superior and Municipal Courts, and authored articles on land use, and environmental and civil rights for the Los Angeles Daily Journal, Los Angeles Lawyer magazine and the National Law Journal. He is also currently a member of the Santa Monica Sustainability Task Force. He is a graduate of UCLA Law School and the UCLA College of Letters and Science, where he majored in philosophy.</p>
<p>Dawn Wilson, SCE</p>	<p>Dawn Wilson, the Director of Environmental Affairs & Sustainability for Southern California Edison (SCE), is responsible for the development of an integrated environmental strategy in support of Company objectives. These responsibilities include Environmental Policy, Natural Resources & Public Lands, Transportation Electrification and the administration of the Corporate Responsibility Program. Prior to her current role Dawn served as the Director of Corporate Resources where she directed the strategy and operations of a \$1 billion portfolio of SCE’s non-electric facilities. Her responsibilities extended to back office functions such as mailing operations, drawing management and event management and the corporate travel program. She had management responsibility for a budget of approximately \$300 million with approximately 300 employees. Over the years Dawn has held a variety of management positions including Director of Business and Organizational Support, Manager Transportation Services, and Manager of Environmental Health & Safety. Dawn began her career as a real estate transactional attorney and practiced with two private law firms before joining the law department of Southern California</p>

	<p>Edison where she practiced environmental law for 14 years. Dawn has served on various non-profit boards and currently serves on the board of the Los Angeles Conservation Corps and the Executive Board of the Pasadena Chapter of Jack & Jill of America. Dawn has a bachelor's degree in political science from Wellesley College and a law degree from the University of Michigan. She is a licensed attorney in the state of California.</p>
<p>Nick Economides, WSPA</p>	<p>Nicholas L. Economides, Manager, State Fuels Regulations at Chevron, has over 30 years of experience in the petroleum refining industry for Mobil, Unocal, Tosco and Chevron. He joined Chevron in 2009 as Manager of State Fuels Regulations and has served in that capacity since then, directing Chevron's regulatory advocacy efforts at the state level. From 2011 to 2014, Mr. Economides also managed Chevron's Product Engineering (Americas) Group overseeing the company's technical service efforts to ensure compliance with all applicable fuel specifications and ensure that Chevron fuel products meet targeted fuel quality standards throughout the product distribution system. Before joining Chevron, Mr. Economides served as Vice President of Technology and Commercial Products for Oryxe Energy Inc., a diesel emission reduction additives manufacturing company based in Irvine, CA. Between 2000 and 2005, Mr. Economides served as General Manager of Refining Technical Services for Hart Energy in Washington, D.C., providing a unique blend of technical research, manufacturing field experience, and planning/economics expertise to focus this global refining and petrochemical consulting company's product services and international refining technical initiatives. Prior to joining Hart, Mr. Economides served as the Director of Technical Programs at the Oxygenated Fuels Association where he oversaw all technical research and advocacy efforts on the benefits and costs of oxygenates in achieving clean fuel objectives. In various assignments throughout the 1990's for Unocal, Tosco, and Mobil, Mr. Economides managed refining planning groups responsible for crude and product trading, capital budgeting, and operations optimization. He coordinated Unocal's compliance with Federal and California fuel specification requirements, heading the interdepartmental taskforce responsible for the introduction of reformulated gasoline in the marketplace. Mr. Economides represented Unocal at the Western States Petroleum Association's Fuels Committee (chairing the group in 1996-1997), the Auto/Oil Study, the Coordinated Research Council and the Society of Automotive Engineers Fuel Committee. Mr. Economides holds a B.S. in Chemical Engineering and a B.A. in English Literature from Columbia University.</p>

***The charter of the TAAG requires membership changes to be approved by the Board's Technology Committee.*

ATTACHMENT C

TECHNOLOGY ADVANCEMENT OFFICE CLEAN FUELS PROGRAM DRAFT 2016 ANNUAL REPORT AND 2017 PLAN UPDATE

**South Coast Air Quality Management District
March 2017**

[This Page Intentionally Left Blank]

South Coast Air Quality Management District

Governing Board

Chairman

William A. Burke, Ed.D.
Assembly Speaker Appointee

Vice Chairman

Ben Benoit
Mayor Pro Tem, City of Wildomar
Riverside County Cities

County Representatives

Sheila Kuehl*
Supervisor, Los Angeles County

Marion Ashley
Supervisor, Riverside County

Shawn Nelson
Supervisor, Orange County

Janice Rutherford*
Supervisor, San Bernardino County

Cities Representatives

Joe Buscaino**
Councilmember, City of Los Angeles
City of Los Angeles

Michael Cacciotti
Mayor, City of South Pasadena
Los Angeles County, Eastern Region Cities

Larry McCallon*
Mayor Pro Tem, City of Highland
San Bernardino County Cities

State Representatives

Joseph K. Lyou, Ph.D.
Governor's Appointee

Dr. Clark E. Parker, Sr.
Senate Rules Committee Appointee

Judith Mitchell*
Councilmember, City of Rolling Hills Estates
Los Angeles County, Western Region Cities

Dwight Robinson*
Councilmember, City of Lake Forest
Orange County Cities

Executive Officer

Wayne Nastri

[This Page Intentionally Left Blank]



*This year's Annual Report and Plan Update
is dedicated in remembrance of*

John J. Benoit

Supervisor, Fourth District, Riverside County

**South Coast Air Quality Management District
Governing Board Member 2010-2016**

Technology Committee Chairman 2012-2016

[This Page Intentionally Left Blank]

*South Coast Air Quality Management District
Technology Advancement Office*

Matt Miyasato, Ph.D., Deputy Executive Officer, Science & Technology Advancement
Fred Minassian, Assistant Deputy Executive Officer, Technology Advancement Office
Naveen Berry, Technology Demonstration Manager
Lourdes Cordova Martinez, Sr. Public Affairs Manager

Al Baez, Program Supervisor
Brian Choe, Program Supervisor
Connie Day, Program Supervisor
Ranji George, Program Supervisor
Joseph Impullitti, Program Supervisor
Lisa Mirisola, Program Supervisor
Vicki White, Program Supervisor

Jason Aspell, Sr. Air Quality Engineer

Vasken Yardemian, Sr. Staff Specialist

Walter Shen, Staff Specialist

Mark Coleman, Air Quality Specialist
Seungbum Ha, Air Quality Specialist
Patricia Kwon, Air Quality Specialist
Joseph Lopat, Air Quality Specialist
Von Loveland, Air Quality Specialist
Krystle Martinez, Air Quality Specialist
Ashkaan Nikravan, Air Quality Specialist
Greg Ushijima, Air Quality Specialist
Mei Wang, Air Quality Specialist
Andrew Yoon, Air Quality Specialist

Greta Grier, Air Quality Inspector II
Arun Kumar, Air Quality Inspector II

Drue Hargis, Sr. Public Information Specialist

Penny Shaw Cedillo, Sr. Administrative Secretary
Pat Krayser, Sr. Administrative Secretary

Marjorie Eaton, Secretary
Alejandra Vega, Secretary
Donna Vernon, Secretary

Michelle White, Staff Assistant

Deanna Doerr, Contracts Assistant
Liliana Garcia, Contracts Assistant
Cassie Johnson, Contracts Assistant
Frances Maes, Contracts Assistant
Mariel Maranan, Contracts Assistant
Genette Prudhomme, Contracts Assistant
Benigna Taylor, Contracts Assistant
Ana Troccoli, Contracts Assistant

Cynthia Synder, Office Assistant

Other Staff Contributors

Henry Hogo, Assistant Deputy Executive Officer, Mobile Sources
Ana Ponce, Sr. Administrative Secretary
Dean Saito, On-Road Mobile Source Manager
Angelica Enriquez, Secretary
Michael Krause, Planning & Rules Manager
Philip Barroca, Air Quality Specialist
Lori Berard, Air Quality Specialist
Richard Carlson, Air Quality Specialist

[This Page Intentionally Left Blank]

Table of Contents

EXECUTIVE SUMMARY	EX-1
Background & Overview.....	1
Program Background	1
Program Review	1
The Need for Advanced Technologies & Clean Fuels	2
Program Funding	5
2016 Overview.....	6
Core Technologies	6
Electric and Hybrid Vehicle Technologies and Infrastructure	8
Hydrogen and Mobile Fuel Cell Technologies and Infrastructure	8
Engine Systems	9
Fueling Infrastructure and Deployment (NG/RNG).....	10
Health Impacts, Emissions and Fuel Studies.....	10
Stationary Clean Fuel Technologies.....	10
Emission Control Technologies	11
Technology Assessment/Transfer and Outreach	11
Barriers, Scope and Impact	13
Overcoming Barriers.....	13
Scope and Benefits of the Clean Fuels Program	13
Strategy and Impact	15
Research, Development and Demonstration	16
Technology Deployment and Commercialization.....	22
2016 Funding & Financial Summary	35
Funding Commitments by Core Technologies.....	35
Review of Audit Findings.....	36
Project Funding Detail by Core Technologies	37
Project Summaries by Core Technologies.....	43
Hydrogen and Mobile Fuel Cell Technologies and Infrastructure	43
Electric/Hybrid Technologies and Infrastructure	46
Engine Systems	50
Fueling Infrastructure and Deployment (NG/RNG).....	50
Fuels/Emissions Studies	53
Technology Assessment/Transfer and Outreach	55
Progress and Results in 2016	59
Key Projects Completed	59
2017 Plan Update	67
Overall Strategy	67
Program and Funding Scope	68
Core Technologies.....	70
Target Allocations to Core Technology Areas	76
Program Plan Update for 2017	77
Funding Summary of Potential Projects	77
Technical Summaries of Potential Projects	81
Electric/Hybrid Technologies & Infrastructure.....	81
Hydrogen and Fuel Cell Technologies & Infrastructure	88
Engine Systems	92
Fueling Infrastructure and Deployment (NG/RNG).....	94
Fuels/Emission Studies	97

Stationary Clean Fuel Technologies	100
Emission Control Technologies	103
Health Impacts Studies	105
Technology Assessment/Transfer & Outreach	108
 Appendix A	
Technology Advancement Advisory Group	A-1
SB 98 Clean Fuels Advisory Group.....	A-2
 Appendix B	
Open Clean Fuels Contracts as of January 1, 2017.....	B-1
 Appendix C	
Final Reports for 2016	C-1
 Appendix D	
Project Ranking.....	D-1
 Appendix E	
Acronyms.....	E-1
Figure 1: Top NOx Sources in 2023	3
Figure 2: NOx Reductions Needed by 2023 & 2031	3
Figure 3: Stages of Clean Fuels Program Projects.....	14
Figure 4: US Hybrid CNG PHET	17
Figure 5: TransPower Battery Electric Trucks	17
Figure 6: BYD T9 Prototype.....	17
Figure 7: BYD T9 Prototype.....	18
Figure 8: Typical Heavy Duty Drayage Truck	19
Figure 9: ISL-G Natural Gas Engine	20
Figure 10: 8.8-Liter PSI Natural Gas Engine.....	20
Figure 11: Los Angeles-Goods Movement and Industrial Corridor	20
Figure 12: Proposed Kenworth Truck Chassis	21
Figure 13: UPS Truck Chassis for Conversion.....	21
Figure 14: Phase 1 Vehicle Modeling.....	22
Figure 15: CR&R’s Anaerobic Digestion Flow Chart.....	23
Figure 16: CR&R’s Anaerobic Digester.....	23
Figure 17: KORE Pyrolysis Unit	24
Figure 18: Methanation.....	24
Figure 19: Ontario CNG Station	24
Figure 20: Class 8 and MDV CNG Refueling	25
Figure 21: CNG Storage Spheres.....	25
Figure 22: Hydrogen Infrastructure Rollout in the SCAQMD	26
Figure 23: CDFA/DMS Testing Air Liquide System Co-located at Anaheim 76 Station with NREL HyStEP Equipment.....	27
Figure 24: San Juan Capistrano Retail Hydrogen Station Co-located by Linde at 76 Gas Station	27
Figure 25: FirstElement Retail Hydrogen Station Co-located at ARCO Gas Station in Long Beach	28
Figure 26: Station Shortfall Projection Source: Joint Agency Staff Report on AB 8 released January 2017	29
Figure 27: DC Fast Charging Station in SCAQMD	30
Figure 28: CEC Funded DC Fast Charging Corridors in SoCal	31

Figure 29: DC Fast Charging Station at City of Calabasas City Hall32
Figure 30: SoCalFast Education Outreach Campaign for PEV Drivers32
Figure 31: Areas of EV Charger Installations at SCAQMD Headquarters33
Figure 32: Installations in Progress33
Figure 33: Greenlots Phone App and Networking Software34
Figure 34: Distribution of Funds for Executed Clean Fuels Projects CY 2016 (\$21.8M)36
Figure 35: ISX15-G Ultra Low NOx Prototype Engine60
Figure 36: ISX15-G Ultra Low NOx Test Engine60
Figure 37: Odyne Plug In Hybrid System61
Figure 38: Odyne Utility Bucket Truck.....62
Figure 39: Burbank Hydrogen Station62
Figure 40: Projected Cost Distribution for Potential SCAQMD Projects in 2017 (\$16.5M).....76

Table 1: SCAQMD Major Funding Partners in CY 201616
Table 2: Contracts Executed or Amended (w/\$) between January 1 & December 31, 201638
Table 3: Supplemental Grants/Revenue Received into the Clean Fuels Fund (31) in CY 201641
Table 4: Summary of Federal, State and Local Funding Awarded or Recognized in CY 2016.....41
Table 5: Emissions Testing Results60
Table 6: Projects Completed between January 1 & December 31, 201663
Table 7: Summary of Potential Projects for 201779

[This Page Intentionally Left Blank]

EXECUTIVE SUMMARY

Introduction

The South Coast Air Quality Management District (SCAQMD) is the air pollution control agency for all of Orange County and the urban portions of Los Angeles, Riverside and San Bernardino counties. This region, which encompasses all of the South Coast Air Basin plus small portions of the Mojave Desert and Salton Sea Air Basins, historically experiences the worst air quality in the nation due to the natural geographic and atmospheric conditions of the region, coupled with the high population density and associated mobile and stationary source emissions. Recognizing this challenge, in 1988 the state established the SCAQMD's Clean Fuels Program (Program), along with the SCAQMD's Technology Advancement Office (TAO). The Clean Fuels Program affords the SCAQMD the ability to fund development, demonstration and accelerated deployment of clean fuels and transportation technologies.

For over 20 years, using funding received through a \$1 motor vehicle registration fee, the Clean Fuels Program has encouraged, fostered and supported clean fuels and transportation technologies, such as hydrogen and fuel cells, natural gas engines and infrastructure, battery electric vehicles, plug-in hybrid electric vehicles and related fueling infrastructure. A key strategy of the Program, which allows significant leveraging of the Clean Fuels funding (typically \$3-\$4 to every \$1 of Clean Fuels funds), is its public-private partnership with private industry, technology developers, academic institutions, research institutions and government agencies. Further, while the TAO aggressively seeks to leverage funds to accomplish more with every dollar, it also strives to be a leader in technology development and commercialization to accelerate the reduction of criteria pollutants. As a result, the TAO Clean Fuels Program has traditionally supported a portfolio of technologies, in different stages of maturity, to provide a continuum of emission reductions and health benefits over time. This approach provides the greatest flexibility and optimizes the region's ability to achieve National Ambient Air Quality Standards (NAAQS).

Health & Safety Code (H&SC) 40448.5.1 requires the SCAQMD to prepare, and submit to the Legislative Analyst each year, a Clean Fuels Annual Report and Plan Update. The Clean Fuels Annual Report looks at what the Program accomplished in the prior calendar year (CY) and the Clean Fuels Plan Update looks ahead at proposed expenditures for the next CY, essentially re-calibrating the technical emphasis of the Program. Preliminary review and comment by SCAQMD's Governing Board, advisory groups, technical experts and other interested parties are incorporated into the Final Plan Update, along with the Clean Fuels Annual Report, which are due to the Legislative Analyst by March 31 of every year.

The overall strategy of the TAO's Clean Fuels Program is based, in large part, on emission reduction technology needs identified through the Air Quality Management Plan (AQMP) process and the SCAQMD Governing Board's directives to protect the health of residents in Southern California, with its approximately 17 million people (nearly half the population of California). The AQMP is the long-term regional "blueprint" that defines:

- basin-wide emission reductions needed to achieve federal ambient air quality standards;
- regulatory measures to achieve those reductions;
- timeframes to implement these proposed measures; and
- technologies required to meet these future proposed regulations.

The emission reductions and control measures in the Draft 2016 AQMP, which will be considered for adoption by the SCAQMD Governing Board on March 3, 2017, rely on a mix of currently available technologies as well as the expedited development and commercialization of lower-emitting mobile

and stationary advanced technologies in the Basin to achieve air quality standards. The Draft 2016 AQMP projects that an approximate 45 percent reduction in NO_x is required by 2023 and an additional 55 percent reduction by 2031. The majority of these NO_x reductions must come from mobile sources, both on- and off-road. Notably, the SCAQMD is currently only one of two regions in the nation recognized as an extreme ozone nonattainment area (the other is San Joaquin Valley). Ground level ozone (a key component of smog) is created by a chemical reaction between NO_x and volatile organic compound (VOC) emissions. This is especially noteworthy because in the South Coast Air Basin the largest contributor to ozone is NO_x emissions, and mobile sources contribute approximately 88 percent of the NO_x emissions in this region. Furthermore, NO_x emissions, along with VOC emissions, also lead to the formation of PM_{2.5} [particulate matter measuring 2.5 microns or less in size, expressed as micrograms per cubic meter (µg/m³)]. The following illustrates the South Coast Air Basin’s carrying capacity for NO_x in tons per day and illustrates the sharp reductions needed for attainment.

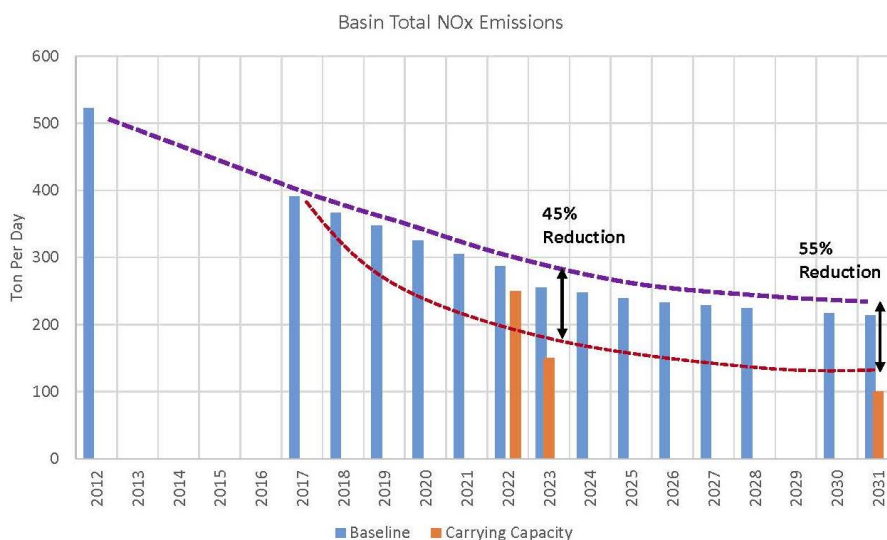

The Draft 2016 AQMP includes integrated strategies and measures to demonstrate attainment of the following National Ambient Air Quality Standards:

Standard	Concentration	Classification	Latest Attainment Year
2008 8-hour Ozone	75 ppb	Extreme	2031
2012 Annual PM _{2.5}	12 µg/m ³	Serious*	2025
2006 24-hour PM _{2.5}	35 µg/m ³	Serious	2019
1997 8-hour Ozone	80 ppb	Extreme	2023
1979 1-hour Ozone	120 ppb	Extreme	2022

* The 2016 AQMP requests a reclassification from moderate to serious non-attainment for this standard

On a positive note, the Draft 2016 AQMP for the first time envisions Southern California achieving attainment through regulations and specifying further deployment of cleaner technologies formerly undefined as “blackbox” measures. This is due in part because of deployment of zero and near-zero technologies either commercialized or nearing commercialization, albeit with pathways that still require more specificity and scalability, and in part because of the emission reduction co-benefits from carbon dioxide (CO₂) reductions expected from achievement of climate change goals as well as an adequate level of funds to incentivize the deployment of these cleaner technologies. There are significant challenges to getting there, however, including EPA and CARB moving forward with changing the heavy-duty engine exhaust NO_x standard from 0.2 grams per break horsepower-hour (g/bhp-hr) to 0.02

g/bhp-hr, as well as identifying financial incentives to offset the higher cost of these emerging clean technologies.

In connection with that challenge, on June 3, 2016, the EPA received a Petition, led by SCAQMD and joined by many other state air quality management agencies, to initiate rulemaking guidelines to create a national standard for ultra-low NO_x heavy-duty engines. The EPA has since acknowledged a need for additional NO_x reductions through a harmonized and comprehensive national NO_x reduction program for heavy duty on-highway engines and vehicles. The EPA has initiated action towards proposed rulemaking for a revised heavy-duty NO_x program, with the intent of proposing standards that could begin model year 2024, consistent with the lead-time requirements of the Clean Air Act.

The Draft 2016 AQMP also takes an initial look at the emission reductions needed to meet the new federal 8-hour ozone air quality standard of 70 ppb and projects that an additional 25 tons per day (tpd) in NO_x reductions between 2031 and 2037 will be needed for attainment in 2037, to be accomplished in part through greater implementation of incentivized zero emission technologies.

The daunting challenge to reduce NO_x and PM_{2.5} to meet standards requires the Clean Fuels Program to encourage and accelerate advancement of advanced clean fuel and transportation technologies, leading the way to commercialization of progressively lower-emitting fuels and vehicles. Given the relationship between NO_x, ozone and PM_{2.5}, the 2017 Plan Update must emphasize emission reductions in all these areas. However, the confluence of federal, state and local planning efforts on climate change, greenhouse gases (GHGs), petroleum reduction, air quality and other environmental areas should provide co-benefits that may help the region.

Since development of the 2012 AQMP, given the region's thriving goods movement industry, it became clear that the effect of moving containers through the Ports of Los Angeles and Long Beach and the subsequent movement of goods throughout the region not only has a dramatic impact on air quality but also the quality of life in the communities along the major goods movement corridors. In recognition of these impacts, the SCAQMD has been leading a concerted effort to develop and demonstrate zero and near-zero emissions goods movement technologies, such as electric trucks, plug-in hybrid trucks with all-electric range, fuel cell and natural gas range-extended trucks, and catenary technology. The SCAQMD goods movement projects that have been initiated or anticipated incorporate a variety of fuels, including electricity, natural gas, biofuels, hydrogen and diesel. The prioritization of these types of projects is reflected in this Draft 2017 Plan Update.

The proposed funding allocations and prioritization are commensurate with the emissions inventory for the various categories that need significant NO_x emission reductions. Staff has also included a simplified "Consumer Reports" type project ranking (Appendix D) for the core technologies discussed in the Annual Report and Plan.

2016 Annual Report

During CY 2016 the SCAQMD executed 60 new contracts, projects or studies and modified 6 continuing projects adding additional dollars toward research, development, demonstration and deployment (RDD&D) of alternative fuel and clean fuel technologies. Table 2 (page 38) lists these 66 projects or studies, which are further described in this report. The SCAQMD Clean Fuels Program contributed nearly \$21.8 million in partnership with other governmental organizations, private industry, academia and research institutes, and interested parties, with total project costs of a bit more than \$198 million. Table 3 (page 41) provides information on outside funding received into the Clean Fuels Fund (\$3.42 million in 2016) as cost-share passed through the SCAQMD for the contracts executed in CY 2016. Table 4 (page 41) provides a comprehensive summary of federal, state and other revenue awarded to the SCAQMD during CY 2016 (approximately \$48.9 million) for projects to be included within the

Clean Fuels Program or which align well with and are complementary to the Clean Fuels Program. The significant project scopes of a few key contracts executed in 2016 resulted in leveraging \$9 for every \$1 of Clean Fuels funding, whereas typical leveraging is \$3-\$4 for every \$1 in Clean Fuels funding. Leveraging dollars and aggressively applying for additional funds whenever funding opportunities arise is more important than ever given the magnitude of additional funding identified in the Draft 2016 AQMP to achieve federal ozone air quality standards.

The projects or studies executed in 2016 addressed a wide range of issues and opportunities with a diverse mix of advanced technologies. The following core areas of technology advancement for 2016 executed contracts (in order of funding percentage) include:

- Electric and Hybrid Vehicle Technologies and Related Infrastructure (emphasizing electric and hybrid electric trucks and container transport technologies with zero emission operations);
- Fueling Infrastructure and Deployment (predominantly natural gas and renewable fuels);
- Hydrogen and Mobile Fuel Cell Technologies and Infrastructure;
- Engine Systems (emphasizing alternative and renewable fuels for truck and rail applications);
- Technology Transfer/Assessment and Outreach; and
- Fuels and Emission Studies.

The pie chart on page 36 shows the distribution by percentage of executed agreements in 2016 across these core technologies.

During CY 2016, the SCAQMD supported a variety of projects and technologies, ranging from near-term to long-term research, development, demonstration and deployment activities. This “technology portfolio” strategy provides the SCAQMD the ability and flexibility to leverage state and federal funding while also addressing the specific needs of the South Coast Air Basin (Basin). Projects executed in CY 2016 included but are not limited to continued development and demonstration of electric and hybrid technologies with an emphasis on zero emission goods movement technologies, large-scale production of renewable natural gas (RNG) as well as demonstration of next generation engines using RNG, development and demonstration of hydrogen technologies and infrastructure, and development and demonstration of heavy-duty natural gas and ultra-low emission diesel engines and vehicles.

As of January 1, 2017, there were 93 open contracts (Appendix B) in the Clean Fuels Program.

Thirty-two (32) RDD&D projects or studies and 11 technology assessment and transfer contracts were completed in 2016, as listed in Table 6 (page 63). Appendix C comprises two-page summaries of the technical projects completed in 2016. In accordance with California Health and Safety Code Section 40448.5.1(d), this report must be submitted to the state legislature by March 31, 2017, after approval by the SCAQMD Governing Board.

2017 Plan Update

The overall strategy is based in large part on technology priorities and opportunities identified in the SCAQMD’s AQMP and the SCAQMD Governing Board’s directives to protect the health of residents in the Basin. The NO_x, VOC and PM emission sources of greatest concern are heavy-duty on-road vehicles, medium- and light-duty on-road vehicles, and off-road equipment. Ocean-going vessels and locomotives remain a concern for the region, but at this time only the federal government has the authority to regulate them. Notwithstanding, TAO works with maritime and railroad companies to push the envelope in these areas as well.

Every year TAO staff re-evaluates the Clean Fuels Program to develop a Plan Update which essentially serves to re-assess the technology progress and direction for the agency. The Program continually seeks to support the development and deployment of lower-emitting technologies. The design and implementation of the Program Plan must balance the needs in the various technology sectors with technology readiness, emissions reduction potential and cofunding opportunities. As the state and federal governments have turned a great deal of their attention to climate change and petroleum reduction goals, the SCAQMD has remained committed to developing, demonstrating and commercializing zero and near-zero emission technologies. Fortunately many, if not the majority, of technology sectors that address our need for NO_x reductions also garner reductions in greenhouse gas (GHG) and petroleum use. Due to these “co-benefits,” the SCAQMD has been successful in partnering with the state and federal government, which allows the Clean Fuels Program to leverage its funding extensively.

To identify technology and project opportunities where funding can make a significant difference in deploying progressively cleaner technologies in the Basin, the SCAQMD employs a number of outreach and networking activities. These activities range from close involvement with state and federal collaboratives, partnerships and industrial coalitions, to the issuance of Program Opportunity Notices to solicit project ideas and concepts as well as issuance of Requests for Information (RFI) to determine the state of various technologies and the development and commercialization challenges faced by those technologies. For example, last year an RFI was released to solicit information from diesel engine manufacturers and other entities to identify ultra-low NO_x emission technology strategies that will result in commercially viable diesel engine technologies capable of using renewable diesel for on-road heavy-duty vehicles that are capable of achieving emission levels 90% cleaner than the current 2010 emission standards for NO_x and reduce particulate matter emissions to the greatest extent possible. Potential projects resulting from this RFI are included conceptually within the Draft 2017 Plan Update.

The Plan Update includes projects to develop, demonstrate and commercialize a variety of technologies, from near-term to long-term commercialization, that are intended to provide solutions to the emission control needs identified in the Draft 2016 AQMP. As noted, the Draft 2016 AQMP analysis indicates that an approximate 45 percent reduction in NO_x is required by 2023 with an additional 55 percent NO_x reduction by 2031. Given the need for these significant reductions over the next 6-14 year timeframe, mid- and longer-term alternative fuels, hybrid, electric and fuel cell based technologies are emphasized. Areas of focus include:

- reducing emissions from port-related activities, such as cargo handling equipment and container movement technologies, including demonstration and deployment of cargo container movement systems with zero emission range;
- mitigating criteria pollutant increases from renewable fuels, such as renewable natural gas, diesel and hydrogen as well as other renewable fuels and waste streams;
- development and demonstration of electric-drive (fuel cell, battery, plug-in hybrid and hybrid) technologies across light-, medium- and heavy-duty platforms;
- producing transportation fuels and energy from renewable and waste stream sources; and
- establishing large-scale hydrogen refueling and EV charging infrastructure to help accelerate the introduction zero emission vehicles into the market.

Table 7 (page 79) lists the potential projects across the nine core technologies identified in this report. Potential projects for 2017 total \$16.5 million, with anticipated leveraging of more than \$4 for every \$1 of Clean Fuels funding, for total project costs of nearly \$70 million. The proposed projects may also be funded by revenue sources other than the Clean Fuels Program, especially VOC and incentive projects.

[This Page Intentionally Left Blank]

CLEAN FUELS PROGRAM

Background & Overview

Program Background

The South Coast Air Basin, which comprises all of Orange County and the urban portions of Los Angeles, San Bernardino and Riverside Counties, has the worst air quality in the nation due to a combination of factors, including high vehicle population, high vehicle miles traveled within the region and geographic and atmospheric conditions favorable for photochemical oxidant (smog) formation. Due to these challenges, the state legislature enabled the SCAQMD to implement the Clean Fuels Program to accelerate the implementation and commercialization of clean fuels and advanced technologies. In 1999, state legislation was passed which amended and extended the Clean Fuels Program. Specifically, as stated in the California Health and Safety Code (H&SC) section 40448.5.1(d), the SCAQMD must submit to the Legislature, on or before March 31 of each year, an annual report that includes:

1. A description of the core technologies that the SCAQMD considers critical to ensure attainment and maintenance of ambient air quality standards and a description of the efforts made to overcome barriers to commercialization of those technologies;
2. An analysis of the impact of the SCAQMD's Clean Fuels Program on the private sector and on research, development and commercialization efforts by major automotive and energy firms, as determined by the SCAQMD;
3. A description of projects funded by the SCAQMD, including a list of recipients, subcontractors, cofunding sources, matching state or federal funds and expected and actual results of each project advancing and implementing clean fuels technology and improving public health;
4. The title and purpose of all projects undertaken pursuant to the Clean Fuels Program, the names of the contractors and subcontractors involved in each project and the amount of money expended for each project;
5. A summary of the progress made toward the goals of the Clean Fuels Program; and
6. Funding priorities identified for the next year and relevant audit information for previous, current and future years covered by the project.

Furthermore, H&SC section 40448.5.1(a)(2) requires the SCAQMD to find that the proposed program and projects funded as part of the Clean Fuels Program will not duplicate any other past or present program or project funded by the state board and other government and utility entities. This finding does not prohibit funding for programs or projects jointly funded with another public or private agency where there is no duplication. The following section describes the panel of external experts that helps review the Clean Fuels Program.

Program Review

In 1990, the SCAQMD initiated an annual review of its technology advancement program by an external panel of experts. That external review process has evolved, in response to SCAQMD policies and legislative mandates, into two external advisory groups. The Technology Advancement Advisory Group (one of six standing Advisory Groups that make up the SCAQMD Advisory Council) is made up of stakeholders representing industry, academia, regulatory agencies, the scientific community and environmental impacts. The Technology Advancement Advisory Group serves to:

- Coordinate the SCAQMD program with related local, state and national activities;

- Review and assess the overall direction of the program; and
- Identify new project areas and cost-sharing opportunities.

In 1999, the second advisory group was formed as required by SB 98 (Alarcon). Under H&SC Section 40448.5.1(c), this advisory group must comprise 13 members with expertise in clean fuels technology and policy or public health and appointed from the scientific, academic, entrepreneurial, environmental and public health communities. This legislation further specified conflict-of-interest guidelines prohibiting members from advocating expenditures towards projects in which they have professional or economic interests. The objectives of the SB 98 Clean Fuels Advisory Group are to make recommendations regarding projects, plans and reports, including consulting with regarding approval of the required annual report prior for submittal to the SCAQMD Governing Board. Also in 1999, in light of the formation of the Clean Fuels Advisory Group, the SCAQMD also revisited the charter and membership of the Technology Advancement Advisory Group to ensure their functions would complement each other.

On an as-needed basis, changes to the composition of the Clean Fuels Advisory Group are reviewed by the SCAQMD Governing Board while changes to the Technology Advancement Advisory Group are reviewed by the SCAQMD Governing Board's Technology Committee. Current membership changes to both advisory groups, if required, will be considered by the SCAQMD Governing Board and its Technology Committee, respectively, as part of consideration of the 2016 Annual Report and 2017 Plan Update. The current members of the SB 98 Clean Fuels Advisory Group and Technology Advancement Advisory Group are listed in Appendix A, with any proposed changes, subject to SCAQMD Governing Board approval, duly noted.

The review process of the Clean Fuels Program now includes at minimum: 1) two full-day retreats of the two Advisory Groups, typically in the summer and winter; 2) review by other technical experts; 3) occasional technology forums or roundtables bringing together interested parties to discuss specific technology areas; 4) review by the Technology Committee of the SCAQMD Governing Board; 5) a public hearing of the Annual Report and Plan Update before the full SCAQMD Governing Board, along with adoption of a resolution finding that the proposed program and projects funded as part of the Clean Fuels Program will not duplicate any other past or present program or project funded by the state board and other government and utility entities, as required by the H&SC; and 6) finally submittal of the Clean Fuels Program Annual Report and Plan Update to the Legislature by March 31 of every year.

The Need for Advanced Technologies & Clean Fuels

Achieving federal and state clean air standards in Southern California will require emission reductions from both mobile and stationary sources beyond those expected using current technologies. Figure 1 reflects the top NO_x emission sources in 2023, emphasizing the need to target technology advancements in the goods movement industry as well as off-road equipment. The need for advanced technologies and clean fuels is best illustrated by Figure 2 below, which identifies NO_x emissions by category and identifies just how far those emissions must be reduced to meet federal standards by 2023 and 2031.

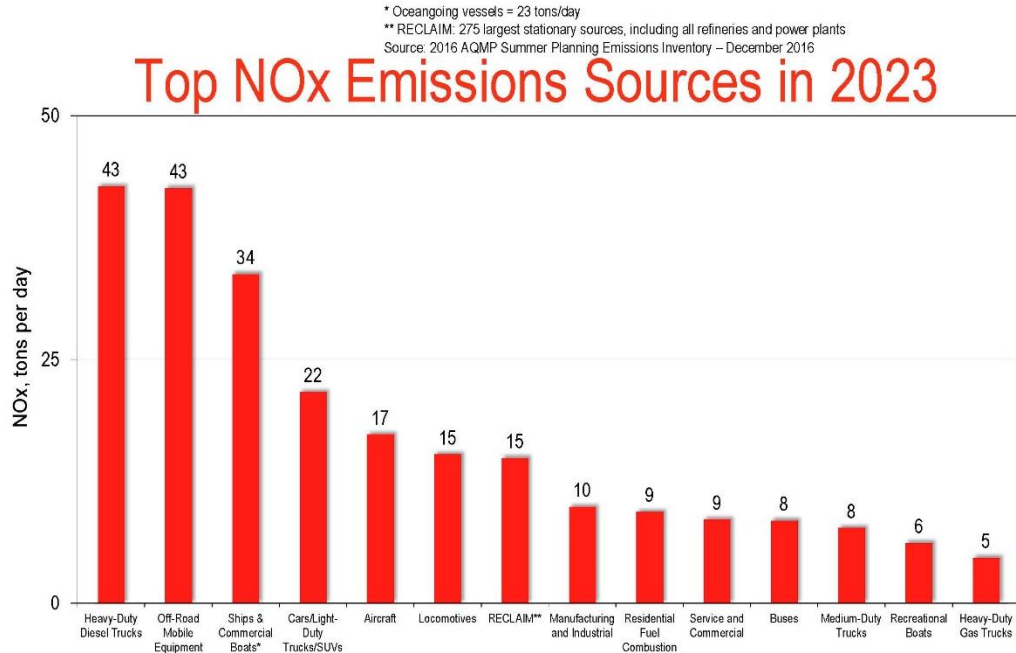

Figure 1: Top NOx Sources in 2023

Needed Pollution Reduction to Meet Ozone Air Quality Standards

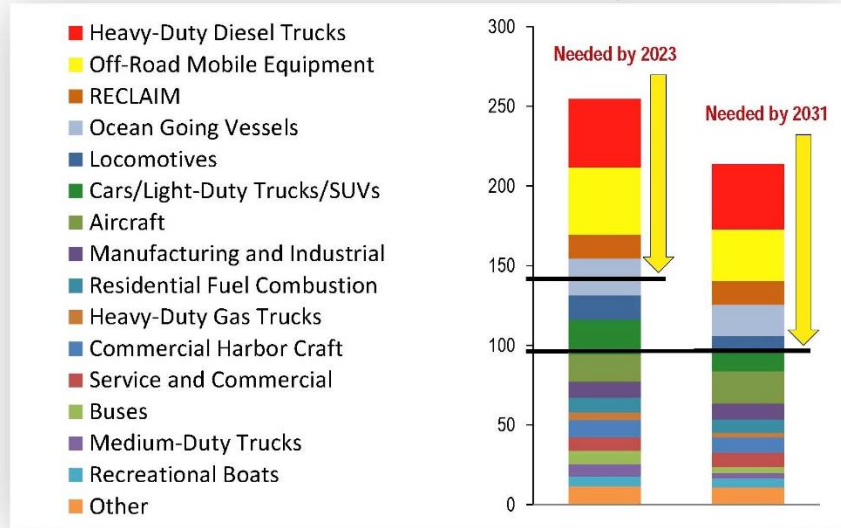

Figure 2: NOx Reductions Needed by 2023 & 2031

The above charts reflect NOx contributors by sector, sharply illustrating the impact of mobile sources on air quality and why the Draft 2016 AQMP calls for an approximate 45 percent reduction of NOx by 2023.

To fulfill long-term emission reduction targets, the Draft 2016 AQMP relies on a mix of currently available technology as well as the expedited development and demonstration of advanced technologies that are not yet ready for commercial use. Significant reductions are anticipated from implementation

of advanced control technologies for both on-road and off-road mobile sources. In addition, the air quality standards for ozone (80 ppb, 8-hour average) and fine particulate matter, promulgated by the U.S. Environmental Protection Agency (U.S. EPA) in 1997 and 2006, are projected to require additional long-term control measures for both NO_x and VOC. The Draft 2016 AQMP's estimate of needed NO_x reductions will require the SCAQMD Clean Fuels Program to encourage and accelerate advancement of clean transportation technologies that are used as control strategies in the AQMP.

Health studies also indicate a greater need to reduce NO_x emissions and toxic air contaminant emissions. For example, the goal of SCAQMD's Multiple Air Toxics Exposure Study (MATES) IV, initially launched in 2012, like the prior three MATES efforts, was to assess air toxic levels, update risk characterization, and determine gradients from selected sources. However, MATES IV added ultrafine PM and black carbon monitoring components as well. The study found a dramatic decrease in ambient levels of diesel particulate matter and other air toxics. Diesel PM was still the major driver of air toxics health risks. While the levels and exposures decreased, a revision to the methods used to estimate cancer risk from toxics developed by the California Office of Health Hazard Identification increased the calculated risk estimates from these exposures by a factor of up to three.

In October 2015, the Governor signed SB 350 (De León) to codify goals outlined in his January 2015 inaugural address to help California meet climate targets for 2030 and beyond, including increasing the amount of electricity generated from renewable sources from 33 to 50 percent, a goal that will dramatically reshape California's energy economy over the next decade. Furthermore, in July 2016, in response to an Executive Order issued by Governor Brown the previous year, a draft California Sustainable Freight Action Plan was released¹, outlining a transition to a more efficient, economically competitive, and cleaner freight transport system. In November 2016, CARB also released a revised draft of the Short Lived Climate Pollutant strategy to address emissions from methane, black carbon and hydrofluorocarbons (HFCs).

The emission reductions needed for this region are outlined further in CARB's draft "Mobile Source Strategy" (May 2016)², which is an integrated plan to transform California's mobile sector. Specifically, it calls for California to build upon its successful efforts to meet critical air quality and climate goals, as summarized below:

- Attaining federal health-based air quality standards for ozone in 2023 and 2031 in the South Coast and San Joaquin Valley, and fine particulate matter (PM_{2.5}) standards in the next decade;
- Achieving GHG emission reduction targets of 40 percent below 1990 levels by 2030;
- Reducing our petroleum use by up to 50 percent by 2030;
- Minimizing health risk from exposure to toxic air contaminants; and
- Increasing energy efficiency and deriving 50 percent of our electricity from renewable sources by 2030.

The document focuses on mobile sources, both on- and off-road equipment, that are responsible for approximately 80 percent of smog-forming NO_x emissions, 95 percent of diesel particulate matter emissions and 50 percent of GHG emissions. Given this contribution, significant cuts in pollution from these sources are needed, therefore the proposed mobile source strategy calls for establishing requirements for cleaner technologies (both zero and near-zero) and deploying these technologies into the fleet, requiring cleaner and renewable fuels, and ensuring continued clean performance in use. Actions to accelerate the deployment of cleaner technologies through incentives, efficiency increases in moving people and freight, and support for the use of advanced transportation technologies

¹ <http://www.dot.ca.gov/casustainablefreight/theplan.html>

² <https://www.arb.ca.gov/planning/sip/2016sip/2016mobsrc.pdf>

such as intelligent transportation systems and autonomous vehicles, are also needed. Taken together, these actions would provide the reductions necessary from mobile sources to achieve the air quality and climate goals outlined above.

In summary, advanced, energy efficient and renewable technologies are needed not only for attainment, but also to protect the health of those who reside within the SCAQMD's jurisdiction; to reduce long-term dependence on petroleum-based fuels; and to support a more sustainable energy future. Conventional strategies and traditional supply and consumption need to be retooled in order to achieve the federal air quality goals. To help meet this need for advanced, clean technologies, the SCAQMD Governing Board continues to aggressively carry out the Clean Fuels Program and promote alternative fuels through its Technology Advancement Office (TAO).

The Clean Fuels Program is intended to assist in the accelerated development and deployment of progressively lower-emitting technologies and fuels through innovative public-private partnership. Since its inception, SCAQMD's TAO has cofunded projects in cooperative partnerships with private industry, technology developers, academic and research institutions and local, state and federal agencies. The following sections describe program funding, provide a 2016 overview and describe core technologies of the Clean Fuels Program.

Program Funding

The Clean Fuels Program is established under California H&SC Sections 40448.5 and 40512 and Vehicle Code Section 9250.11. This legislation establishes mechanisms to collect revenues from mobile and stationary sources to support the program objectives and identifies the constraints on the use of funds. In 2008, these funding mechanisms were reauthorized under SB 1646 (Padilla), which removed the funding sunset of January 1, 2010, and established the five percent administrative cap instead of the previous cap of two-and-half percent.

The Program is funded through a \$1 fee on motor vehicles registered in the SCAQMD. Revenues collected from these motor vehicles must be used to support mobile source projects. Stationary source projects are funded by an emission fee surcharge on stationary sources emitting more than 250 tons of pollutants per year within the SCAQMD. For CY 2016 the funds available through each of these mechanisms were as follows:

- | | |
|---|--------------|
| • Mobile sources (DMV revenues) | \$13,446,456 |
| • Stationary sources (emission fee surcharge) | \$325,326 |

The SCAQMD Clean Fuels Program also receives grants and cost-sharing revenue contracts from various agencies, on a project-specific basis, that supplement the SCAQMD program. Historically, such cooperative project funding revenues have been received from CARB, the CEC, the U.S. EPA, the U.S. Department of Energy (DOE) and the U.S. Department of Transportation (DOT). These supplemental revenues depend in large part on the originating agency, its budgetary and planning cycle and the specific project or intended use of the revenues. Table 3 (page 41) lists supplemental grants and revenues totaling \$3.42 million for contracts executed in CY 2016. Table 4 (page 41) lists federal and state revenue totaling nearly \$48.9 million awarded to the SCAQMD in 2016 for projects that will be part of the Clean Fuels Program or align well and will complement the Clean Fuels Program.

The final and perhaps most significant funding source can best be described as an indirect source, i.e., funding not directly received by the SCAQMD. This indirect source is the cost-sharing provided by private industry and other public and private organizations. Historically, the Technology Advancement Office has been successful in leveraging its available public funds with \$3 to \$4 of outside funding for each \$1 of SCAQMD funding. For 2016, the Clean Fuels Program leveraged each \$1 to more than \$9 of outside funding. This atypical leverage was the result of a few key contracts with significant project scopes executed in 2016, such as the \$23 million award from CARB's California Climate Investment

Program (see Table 2 for more information on these key projects). Through these public-private partnership, the SCAQMD has shared the investment risk of developing new technologies along with the benefits of expedited development and commercial availability, increased end-user acceptance, reduced emissions from the demonstration projects and ultimately increased use of clean technologies in the Basin. While the SCAQMD aggressively seeks leverage funds to accomplish more with every dollar, it also strives to act as a leader in technology development and commercialization in an effort to accelerate the reduction of criteria pollutants. Leveraging dollars and aggressively applying for additional funds whenever funding opportunities arise is more important than ever given the magnitude of additional funding identified in the Draft 2016 AQMP to achieve federal ozone air quality standards. The SCAQMD's Clean Fuels Program has also avoided duplicative efforts by coordinating and jointly funding projects with major funding agencies and organizations. The major funding partners for 2016 are listed in Table 1 (page 16).

2016 Overview

This report summarizes the progress of the SCAQMD Clean Fuels Program for CY 2016. The SCAQMD Clean Fuels Program cosponsors projects to develop and demonstrate zero, near-zero and low-emission clean fuels and advanced technologies and to promote commercialization and deployment of promising or proven technologies in Southern California. These projects are conducted through public-private partnerships with industry, technology developers, academic and research institutes and local, state and federal agencies.

This report also highlights achievements and summarizes project costs of the SCAQMD Clean Fuels Program in CY 2016. During the period between January 1 and December 31, 2016, the SCAQMD executed 60 new contracts, projects or studies and modified 6 continuing projects adding additional dollars during CY 2016 that support clean fuels and advanced zero, near-zero and low-emission technologies. The SCAQMD Clean Fuels Program contribution for these projects was approximately \$21.8 million, inclusive of \$3.42 million received into the Clean Fuels Fund as cost-share for contracts executed in this reporting period, with total project costs of a bit more than \$198 million. These projects address a wide range of issues with a diverse technology mix. The report not only provides information on outside funding received into the Clean Fuels Fund as cost-share for contracts executed in this period (summarized in Table 3, page 41), but also funds awarded to the SCAQMD for projects to be included in the Clean Fuels Program or which align well and are complementary to the Clean Fuels Program (\$48.9 million in 2016, see Table 4). More details on this financial summary can be found later in this report. The SCAQMD will continue to pursue federal, state and private funding opportunities in 2017 to amplify leverage, while acknowledging that support of a promising technology is not contingent on outside cost-sharing and affirming that SCAQMD will remain committed to acting as a leader in developing advanced technologies that lower criteria pollutants.

Core Technologies

Given the diversity of sources that contribute to the air quality problems in the Basin, there is no single technology or “Silver Bullet” that can solve all of the problems. A number of technologies are required and these technologies represent a wide range of applications, with full emissions benefit “payoffs,” i.e., full commercialization and mass deployment occurring at different times. The broad technology areas of focus – the “Core Technologies” – for the Clean Fuels Program are as follows:

- Hydrogen and Fuel Cell Technologies and Infrastructure (especially large-scale refueling facilities)
- Electric and Hybrid Vehicle Technologies and Infrastructure (emphasizing electric and hybrid electric trucks and container transport technologies with zero emission operation)
- Engine Systems (emphasizing heavy-duty alternative and renewable fuel engines for truck and rail applications)

- Fueling Infrastructure and Deployment (predominantly natural gas and renewable fuels)
- Health Impacts, Emissions and Fuel Studies
- Stationary Clean Fuels Technologies
- Emission Control Technologies
- Technology Assessment/Transfer and Outreach

The SCAQMD continually seeks to support the deployment of lower-emitting technologies. The Clean Fuels Program is shaped by two basic factors:

1. Low, near-zero and zero emission technologies needed to achieve clean air standards in the Basin; and
2. Available funding to support technology development within the constraints imposed by that funding.

The SCAQMD strives to maintain a flexible program to address dynamically evolving technologies and the latest progress in the state of the technology while balancing the needs in the various technology sectors with technology readiness, emissions reduction potential and cofunding opportunities. Although the SCAQMD program is significant, national and international activities affect the direction of technology trends. As a result, the SCAQMD program must be flexible in order to leverage and accommodate these changes in state, national and international priorities. Nonetheless, while the state and federal governments have in recent years turned a great deal of their attention to climate change, SCAQMD has remained committed to developing, demonstrating and commercializing zero and near-zero emission technologies. Fortunately many, if not the majority, of technology sectors that address our need for NO_x reductions also garner greenhouse gas (GHG) reductions. Due to these “co-benefits,” the SCAQMD has been successful in partnering with the state and federal government. Even with the leveraged funds, the challenge for the SCAQMD remains the need to identify project or technology opportunities in which its available funding can make a difference in achieving progressively cleaner air in the Basin.

To achieve this, the SCAQMD will need to continue to employ a number of outreach and networking activities as well as evaluate new ways to expand these activities. Typical activities range from intimate involvement with state and federal collaboratives, partnerships and industrial coalitions, to the issuance of Program Opportunity Notices to solicit project ideas and concepts as well as the issuance of Requests for Information to determine the state of various technologies and the challenges faced by those technologies for commercialization. While employing a number of creative outreach and networking activities to try to overcome these challenges, SCAQMD’s TAO annually develops a comprehensive plan to encourage and accelerate the development and demonstration of cleaner technologies. Every year TAO staff re-evaluates the Clean Fuels Program to develop a comprehensive plan (referred to as the 2017 Plan Update within this document) to essentially re-assess the technology progress and direction for the agency.

Historically, mobile source projects have targeted low-emission developments in automobiles, transit buses, medium- and heavy-duty trucks and non-road applications. These vehicle-related efforts have focused on advancements in engine design, electric power-trains and energy storage/conversion devices (e.g., fuel cells and batteries); and implementation of clean fuels (e.g., natural gas, propane and hydrogen) including their infrastructure development. Stationary source projects have included a wide array of advanced low NO_x technologies and clean energy alternatives such as fuel cells, solar power and other renewable and waste energy systems. The focus on recent years has been on zero and near-zero emission technologies to reduce emissions from mobile sources, which contribute to more than 80 percent of the current NO_x emissions in this region. However, while mobile sources include both on- and off-road vehicles as well as aircraft and ships, only the federal government has the authority to regulate emissions from aircraft and ships. The SCAQMD is exploring opportunities to expand its

authority in ways that would allow the agency to do more to foster technology development for ship and train activities as they relate to goods movement.

Specific projects are selected for cofunding from competitive solicitations, cooperative agency agreements and unsolicited proposals. Criteria considered in project selection include emissions reduction potential, technological innovation, potential to reduce costs and improve cost effectiveness, contractor experience and capabilities, overall environmental impacts or benefits, commercialization and business development potential, cost sharing and consistency with program goals and funding constraints. The core technologies for the SCAQMD programs that meet both the funding constraints as well as Draft 2016 AQMP needs for achieving clean air are briefly described below.

Electric and Hybrid Vehicle Technologies and Infrastructure

There has been an increased level of activity and attention on electric and hybrid vehicles due to a confluence of factors, including the highly successful commercial introductions of hybrid passenger vehicles and more recently plug-in electric vehicles (PEVs) by almost all of the automakers and increased public attention on global warming, as well as several Executive Orders issued by Governor Brown over the last couple of years. At the federal level, there is also the continued push for PEVs through the EV Everywhere Program.

The growing awareness by both government and the public for the need for better air quality is leading to stricter emissions targets and a demand for greater fuel efficiency for vehicles. As a result, there is now a window of opportunity to leverage state and federal activities in the development and deployment of technologies that can accelerate advanced electric and hybrid technologies, including medium- and heavy-duty hybrid vehicle deployment, energy storage technologies and other power options, development of medium- and heavy-duty hybrid emission certification cycles, battery durability testing and establishment of driver use patterns. Such technology developments, if successful, are considered enabling because they can be applied to a variety of fuels (e.g., gasoline, natural gas, biofuels and hydrogen) and propulsion systems - e.g., internal combustion engines (ICEs), batteries and fuel cells. In particular, utilizing electric drive technologies to enable zero emission mile capable heavy-duty trucks for goods movement remains a top priority. Electric and hybrid technologies are also being explored to address one of the SCAQMD's 2016-17 Goals and Priority Objectives, which is to continue development and demonstration of zero emission goods movement technologies.

EV adoption surpassed a huge milestone in 2016 selling a quarter of a million electric vehicles in California, according to the PEV Collaborative, and recent announcements by automakers (e.g., Chevrolet, Nissan, Tesla and BMW) on the extended range of upcoming EV models is especially promising. For example, the 2017 Chevy Bolt EV has an estimated EPA range of 238 miles with an affordable price target after incentives. However, in order to achieve the fleet penetration required for clean air, the need for charging infrastructure is significant. One sign of progress in this area is last year's California Public Utility Commission action recognizing the need for transportation electrification and approving Southern California Edison's (SCE's) \$22 million "Charge Ready" pilot program to support installation of as many as 1,500 EV charging stations in their service territory. The SCAQMD will work with SCE to identify the best strategy for EV infrastructure (e.g., destination and residential charging) to complement this new program and continue to work with CEC, other government agencies and private entities to implement installation of charging infrastructure in our region.

Hydrogen and Mobile Fuel Cell Technologies and Infrastructure

Toyota and Hyundai commercialized light-duty fuel cell vehicles in 2015, Honda started delivering their Fuel Cell Clarity in 2016, and numerous others have plans to commercialize their own in the near future. As automakers continue to collaborate on development efforts (e.g., Honda and GM) and commercialize fuel cell vehicles, in the interim plug-in hybrid technology could help enable fuel cells

by using larger capacity batteries until fuel cell components mature. For example, Mercedes-Benz announced production of a plug-in fuel cell model GLC for 2018. However, the greatest challenge for the viability of fuel cell vehicles remains the installation and operations of hydrogen fueling stations. AB 8 requires the CEC to allocate \$20 million annually from the Alternative and Renewable Fuel and Vehicle Technology Program until there are at least 100 publicly accessible hydrogen stations in operation in California. Of the 51 stations funded by CEC and CARB by the end of 2016, partially funded by SCAQMD for those in our region, there are five non-retail and 25 retail operational in California, but most if not all 51 are expected to be operational by the end of 2017 with capacity for more than 10,000 fuel cell vehicles. AB 8 also requires CARB to annually assess current and future FCVs and hydrogen stations in the marketplace. *The Joint Agency Staff Report on Assembly Bill 8: 2016 Assessment of Time and Cost Needed to Attain 100 Hydrogen Refueling Stations in California*³ released in January 2017 reporting on 2016 findings states that there were 925 fuel cell vehicles registered in California by October 2016. However, CARB's annual survey of automakers projects 10,500 fuel cell vehicles in California by the end of 2018 and 34,300 by the end of 2021. Clearly, the SCAQMD must continue to support the infrastructure required to refuel retail fuel cell vehicles. To that end, SCAQMD is also actively engaged in finding alternatives to reducing the cost of hydrogen (e.g., large-scale hydrogen refueling stations) and potential longer term fuel cell power plant technology.

Engine Systems

Medium- and heavy-duty on-road vehicles contributed approximately 33 percent of the Basin's NOx based on Draft 2016 AQMP data. More importantly, on-road heavy-duty diesel trucks account for 33 percent of the on-road mobile source PM_{2.5}, which has known toxic effects. These figures notably do not include the significant contribution from off-road mobile sources, which contribute significantly to NOx and PM_{2.5} emissions in the Basin. Furthermore, while MATES IV found a dramatic decrease in ambient levels of diesel PM and other air toxics, diesel PM is still the major driver of air toxics health risks. Clearly, significant emission reductions will be required from mobile sources, especially from the heavy-duty sector, to attain the federal clean air standards.

The use of alternative fuels in heavy-duty vehicles can provide significant reductions in NOx and particulate emissions. The current NOx emissions standard for heavy-duty engines is 0.2 g/bhp-hr. The SCAQMD, along with various local, state and federal agencies, continues to support the development and demonstration of alternative-fueled low emission heavy-duty engine technologies, using natural gas, renewable diesel and potentially other renewable or waste stream liquid fuels, for applications in heavy-duty transport trucks, transit and school buses, rail operations, and refuse collection and delivery vehicles to meet future federal emission standards. The SCAQMD's FY 2016-17 Goals and Priority Objectives also includes development and demonstration of next-generation natural gas engines/hybrid vehicles with the goal of developing engines 75-90 percent cleaner than the current emissions standard for NOx. Additionally, options for integrating with hybrid systems and alternative fuels need to be explored to provide additional NOx reductions.

In connection with the challenge to develop cleaner engine systems, on June 3, 2016, the EPA received a Petition, led by SCAQMD and joined by many other state air quality management agencies, to initiate rulemaking guidelines to create a national standard for ultra-low NOx heavy-duty engines. The EPA has since acknowledged a need for additional NOx reductions through a harmonized and comprehensive national NOx reduction program for heavy duty on-highway engines and vehicles. The EPA has initiated action towards proposed rulemaking for a revised heavy-duty NOx program, with the intent of proposing standards that could begin model year 2024, consistent with the lead-time requirements of the Clean Air Act and the AQMP goals. If EPA adopts a more stringent heavy-duty NOx standard for the nation, engine manufacturers will be required to step up further to develop cleaner

³ <http://www.energy.ca.gov/2017publications/CEC-600-2017-002/CEC-600-2017-002.pdf>

engines, and this region will also benefit from cleaner vehicles coming into the state as part of the goods movement industry.

Fueling Infrastructure and Deployment (NG/RNG)

A key element for increased use of alternative fueled vehicles and resulting widespread acceptance is the availability of the supporting refueling infrastructure. The refueling infrastructure for gasoline and diesel fuel is well established and accepted by the driving public. Alternative, clean fuels such as alcohol-based fuels, propane, hydrogen, and even electricity are much less available or accessible, whereas natural gas and renewable fuels have recently become more readily available and cost-effective. Nonetheless, to realize emissions reduction benefits, alternative fuel infrastructure, especially fuels from renewable feedstocks, must be developed in tandem with the growth in alternative fueled vehicles. While California appears to be on track to meet its Renewable Portfolio Standard targets of 33% by 2020 and 50% by 2030 as required by SB 350 (chaptered October 2015), the objectives of the SCAQMD are to expand the infrastructure to support zero and near-zero emission vehicles through the development, demonstration and installation of alternative fuel vehicle refueling technologies. However, this category is predominantly targeted at natural gas and renewable natural gas (RNG) infrastructure and deployment (electric and hydrogen fueling are included in their respective technology categories). Changes to the Carl Moyer Program as a result of SB 513 (chaptered October 2015) may help stimulate deployment of alternative and natural gas vehicles and related infrastructure. The Clean Fuels Program will continue to examine opportunities where current incentive funding is either absent or insufficient. Market offerings such as Ford's 2016 F-150 which has the ability to run on natural gas may help further spur demand in this area.

Health Impacts, Emissions and Fuel Studies

The monitoring of pollutants in the Basin is extremely important, especially when focused on (1) a particular sector of the emissions inventory (to identify the responsible technology) or (2) exposure to pollution (to assess the potential health risks). Several studies indicate that areas with high levels of air pollution can produce irreversible damage to children's lungs. This information highlights the need for further emissions and health studies to identify the emissions from high polluting sectors as well as the health effects resulting from these technologies. Considering the transition to alternative and renewable fuels, accelerated by federal and state requirements, it is important to understand the impacts that changing fuel composition will have on exhaust emissions and in turn on ambient air quality. This area focuses on exhaust emission studies, with a focus on NO_x and PM_{2.5} emissions and a detailed review of other potential toxic tailpipe emissions, for alternative fuel and diesel engines, especially in the heavy-duty sector, as well as light- and heavy-duty engines that operate on renewable fuels or higher compression spark- ignited engines. These types of in-use emissions studies have found significantly higher emissions than certification values for heavy-duty diesel engines, depending on the duty-cycle.

Stationary Clean Fuel Technologies

Given the limited funding available to support low emission stationary source technology development, this area has historically been limited in scope. To gain the maximum air quality benefits in this category, higher polluting fossil fuel-fired electric power generation needs to be replaced with clean, renewable energy resources or other advanced near zero-emission technologies, such as solar, wind, geo-thermal energy, bio-mass conversion and stationary fuel cells. Although combustion sources are lumped together as stationary, the design and operating principles vary significantly and thus also the methods and technologies for control of their emissions. Included in the stationary category are boilers, heaters, gas turbines and reciprocating engines. The key technologies for this category focus on using advanced combustion processes, development of catalytic add-on controls, alternative fuels and technologies and stationary fuel cells in novel applications.

Emission Control Technologies

This broad category refers to technologies that could be deployed on existing mobile sources, aircraft, locomotives, marine vessels, farm and construction equipment, cargo handling equipment, industrial equipment, and utility and lawn-and-garden equipment. The in-use fleet comprises the majority of emissions, especially the older vehicles and non-road sources, which are typically uncontrolled and unregulated, or controlled to a much lesser extent than on-road vehicles. The authority to develop and implement regulations for retrofit on-road and non-road mobile sources lies primarily with the U.S. EPA and CARB.

Low-emission and clean-fuel technologies that appear promising for on-road mobile sources should be effective at reducing emissions from a number of non-road sources. For example, immediate benefits are possible from particulate traps and selective catalytic reduction (SCR) that have been developed for diesel applications. Clean fuels such as natural gas, propane, hydrogen and hydrogen-natural gas mixtures may also provide an effective option to reduce emissions from some non-road applications. Reformulated gasoline, ethanol and alternative diesel fuels, such as biodiesel and gas-to-liquid (GTL), also show promise when used in conjunction with advanced emissions controls and new engine technologies.

Technology Assessment/Transfer and Outreach

Since the value of the Clean Fuels Program depends on the deployment and adoption of the demonstrated technologies, technology assessment and transfer efforts are essential to its success. This core area encompasses assessment of advanced technologies, including retaining outside technical assistance as needed, efforts to expedite the implementation of low emission and clean fuels technologies, and coordination of these activities with other organizations. Technology transfer efforts also include support for various clean fuel vehicle incentive programs. The other spectrum of this core technology is information dissemination to educate the end user and increase awareness. While SCAQMD's Public Affairs office oversees and carries out the majority of such education and awareness efforts on behalf of the entire agency, TAO cosponsors and occasionally hosts various technology-related events to complement their efforts. These efforts range from general outreach and partnerships to convening or cosponsoring events. Some examples include: 1) partnerships with local colleges such as Cal State Los Angeles' Hydrogen Research and Fueling Facility; 2) SCAQMD's A World We Can Change high school conferences; 3) participation in the Jet Propulsion Laboratory's Annual Climate Day for middle schoolers promoting STEM education; 4) partnerships for national events such as Drive Electric Week; and 5) hosting tours of SCAQMD's clean fuel vehicle fleet and their respective fueling platforms.

[This Page Intentionally Left Blank]

CLEAN FUELS PROGRAM BARRIERS, SCOPE AND IMPACT

Overcoming Barriers

Commercialization and implementation of advanced technologies come with a variety of challenges and barriers. A combination of real-world demonstrations, education, outreach and regulatory impetus and incentives is necessary to bring new, clean technologies to market. To reap the maximum emissions benefits from any technology, widespread deployment and user acceptance must occur. The product manufacturers must overcome technical and market barriers to ensure a competitive and sustainable business. Barriers include project-specific issues as well as general technology concerns.

Technology Implementation Barriers

- Viable commercialization Path
- Technology price/performance parity with convention technology
- Consumer acceptance
- Fuel availability/convenience issues
- Certification, safety and regulatory barriers
- Quantifying emissions benefits
- Sustainability of market and technology

Project-Specific Issues

- Identifying a committed demonstration site
- Overall project cost and cost-share using public monies
- Securing the fuel
- Identifying and resolving real and perceived safety issues
- Quantifying the actual emissions benefits
- Viability of the technology provider

Other barriers include reduced or shrinking research budgets, infrastructure and energy uncertainties and risks, sensitivity to multi-media environmental impacts and the need to find balance between environmental needs and economic constraints. The SCAQMD seeks to address these barriers by establishing relationships through unique public-private partnerships with key stakeholders; e.g., industry, end-users and other government agencies with a stake in developing clean technologies. Partnerships that involve all the key stakeholders have become essential to address these challenges in bringing advanced technologies from development to commercialization.

Each of these stakeholders and partners contributes more than just funding. Industry, for example, can contribute technology production expertise as well as the experience required for compatibility with process operations. Academic and research institutes bring state-of-the- technology knowledge and testing proficiency. Governmental and regulatory agencies can provide guidance in identifying sources with the greatest potential for emissions reduction, assistance in permitting and compliance issues, coordinating of infrastructure needs and facilitation of standards setting and educational outreach. Often, there is considerable synergy in developing technologies that address multiple goals of public and private bodies regarding the environment, energy and transportation.

Scope and Benefits of the Clean Fuels Program

Since the time needed to overcome barriers can be long and the costs high, both manufacturers and end-users tend to be discouraged from considering advanced technologies. The Clean Fuels Program addresses these needs by cofunding research, development, demonstration and deployment projects to share the risk of emerging technologies with their developers and eventual users.

Figure 3 provides a conceptual design of the wide scope of the Clean Fuels Program. As mentioned in the Core Technologies section, various stages of technology projects are funded not only to provide a portfolio of emissions technology choices but to achieve emission reduction benefits in the nearer as well as over the longer term.

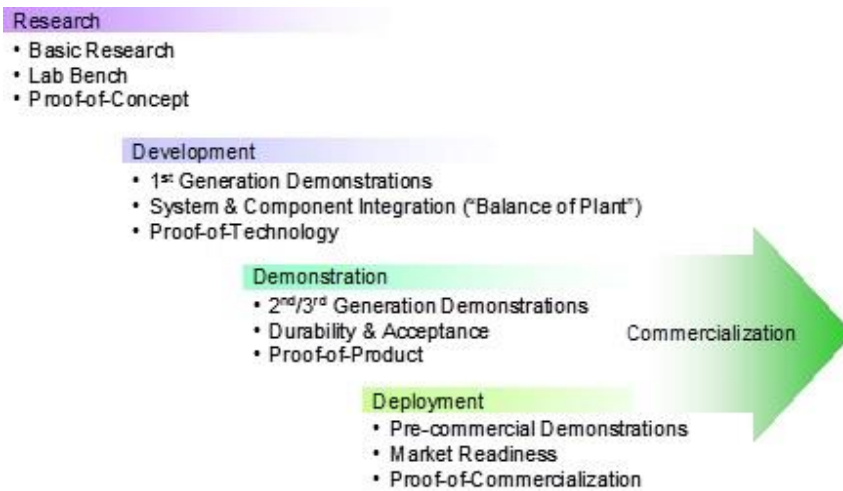

Figure 3: Stages of Clean Fuels Program Projects

Due to the nature of these advanced technology research, development, demonstration and deployment projects, the benefits are difficult to quantify since their full emission reduction potential may not be realized until sometime in the future, or perhaps not at all if displaced by superior technologies. Nevertheless, a good indication of the impact and benefits of the Clean Fuels Program overall is provided by this selective list of sponsored projects that have resulted in commercialized products or helped to advance the state-of-the-technology.

- CNG Engine Development for Heavy-Duty Vehicles
 - Emission Solutions: 7.6L (NG)
 - Cummins Westport: low-NOx natural gas ISL G 8.9L engines (0.2 & 0.02 g/bhp-hr)
 - Westport Power: ISX 15L (LNG), Westport GX 15 L (dual fuel)
 - Detroit Diesel: Series 60G (CNG/LNG), Series 50G (CNG/LNG);
 - John Deere: 6068 (CNG), 6081 (CNG);
 - Mack: E7-400G (LNG); and
 - Clean Air Partners/Power Systems (Caterpillar): 3126B (Dual Fuel), C-10 (Dual Fuel), C-12 (Dual Fuel).
- Fuel Cell Development and Demonstrations
 - Ballard Fuel Cell Bus (first of its kind);
 - Retail light-duty passenger fuel cell vehicles (Toyota Mirai, Hyundai Tucson, Honda Clarity);
 - SunLine Transit Agency Advanced Fuel Cell Bus projects;
 - Commercial stationary fuel cell demonstration with UTC and SoCalGas (first of its kind); and
 - Orange County Sanitation District hydrogen and combined heat and power generation from biogas using molten carbonate fuel cell technology (as well as their renewable hydrogen station).
 - New Flyer Transit Bus at OCTA
 - UPS demonstration of fuel cell delivery trucks

- Fuel cell Class 8 trucks under Zero Emission Cargo Transport (ZECT) II Program
- Electric and Hybrid Electric Vehicle Development and Demonstrations
 - EPRI hybrid vehicle evaluation study;
 - Hybrid electric vehicle demonstrations with SCE, UC Davis and AC Propulsion;
 - Plug-in Hybrid Electric Van with EPRI, DaimlerChrysler and SCE;
 - Hybrid electric delivery trucks with NREL, FedEx and UPS;
 - Proterra battery electric transit bus and fast charging system;
 - Municipal battery electric utility truck;
 - South Bay City Council of Governments' electric vehicle project;
 - EVI/UPS electric truck;
 - Plug-in hybrid work truck with Odyne Systems;
 - Plug-in hybrid van and pickup with VIA Motors;
 - BYD all-electric transit bus;
 - LACMTA battery electric buses;
 - Electric school buses with V2G capability; and
 - TransPower/US Hybrid battery electric heavy-duty truck and yard hostlers.
- Aftertreatment Technologies for Heavy-Duty Vehicles
 - Johnson Matthey and Engelhard trap demonstrations on buses and construction equipment; and
 - Johnson Matthey SCRT and SCCRT NO_x and PM reduction control devices on heavy-duty on-road trucks.

SCAQMD played a leading or major role in the development of these technologies, but their benefits could not have been achieved without all stakeholders (i.e., manufacturer, end-users and government) working collectively to overcome the technology, market and project-specific barriers encountered at every stage of the research, development, demonstration and deployment process.

Strategy and Impact

In addition to the feedback and input detailed in Program Review (pages 1-2), the SCAQMD actively seeks additional partners for its program through participation in various working groups, committees and task forces. This participation has resulted in coordination of the SCAQMD program with a number of state and federal government organizations, including CARB, CEC, EPA and U.S. DOE and several of its national laboratories. Coordination also includes the AB 2766 Discretionary Fund Program administered by the Mobile Source Air Pollution Reduction Review Committee (MSRC), various local air districts, National Association of Fleet Administrators (NAFA), major local transit districts and local gas and electric utilities. The list of organizations with which the SCAQMD coordinates research and development activities also includes organizations specified in H&SC Section 40448.5.1(a)(2).

In addition, the SCAQMD holds periodic meetings with several organizations specifically to review and coordinate program and project plans. For example, the SCAQMD staff meets with CARB staff to review research and development plans, discuss project areas of mutual interest, avoid duplicative efforts and identify potential opportunities for cost-sharing. Periodic meetings are also held with industry-oriented research and development organizations, including but not limited to the California Fuel Cell Partnership (CaFCP), the California Stationary Fuel Cell Collaborative, the California Natural Gas Vehicle Partnership (CNGVP), the California Plug-In Electric Vehicle (PEV) Collaborative, the California Hydrogen Business Council (CHBC) the Electric Power Research Institute (EPRI), the Electric Drive Transportation Association (EDTA), the SoCalEV Collaborative, the West Coast Collaborative, which is part of the National Clean Diesel Campaign, and the Transportation Research Board. The coordination efforts with these various stakeholders have resulted in a number of cosponsored projects.

Descriptions of some of the key contracts executed in CY 2016 are provided in the next section of this report. It is noteworthy that most of the projects are cosponsored by various funding organizations and include the active involvement of original equipment manufacturers. Such partnerships are essential to address commercialization barriers and to help expedite the implementation of advanced low emission technologies. Table 1 below lists the major funding agency partners and manufacturers actively involved in SCAQMD projects for this reporting period. It is important to note that, although not listed, there are many other technology developers, small manufacturers and project participants who make important contributions critical to the success of the SCAQMD program. These partners are identified in the more detailed 2016 Project Summaries (beginning page 43) contained within this report.

Table 1: SCAQMD Major Funding Partners in CY 2016

Research Funding Organizations	Major Manufacturers/Providers
California Air Resources Board	BYD North America
California Energy Commission	Cummins Inc.
National Renewable Energy Laboratory	Cummins Westport, Inc.
U.S. Department of Energy	Kenworth
U.S. Environmental Protection Agency	KORE Industries
MSRC/AB 2766 Discretionary Fund Program	Peterbilt
	Ports of Los Angeles & Long Beach
	Southern California Gas Company
	TransPower
	University of California Riverside/ CE-CERT
	Volvo

The following two subsections broadly address the SCAQMD’s impact and benefits by describing specific examples of accomplishments and commercial—or near-commercial— products supported by the Clean Fuels Program in CY 2016. Such examples are provided in the following sections on the Technology Advancement Office’s Research, Development and Demonstration projects and Technology Deployment and Commercialization efforts.

Research, Development and Demonstration

Important examples of the impact of the SCAQMD research and development coordination efforts include: (a) development and demonstration of zero emissions goods movement technologies; (b) development, integration and demonstration of ultra-low emission natural gas engines for heavy-duty vehicle applications; (c) development and demonstration of a Class 8 fuel cell range-extended electric drayage truck; and (d) develop and demonstrate fuel cell extended-range electric medium-duty truck and powertrain for parcel delivery trucks

Develop and Demonstrate Class 8 Zero Emission Drayage Truck Technologies

Heavy-duty diesel trucks in the South Coast Air Basin remain a significant source of emissions with adverse health impact, especially in the surrounding communities along the goods movement corridors near the Ports of Los Angeles and Long Beach (Ports), and next to major freeways. In order to mitigate

the impact and attain stringent national ambient air quality standards for the region, SCAQMD has been aggressively promoting and supporting development and demonstration of advanced zero emission cargo transport technologies, in partnership with the Southern California Regional Zero Emission Truck Collaborative, comprised of the Los Angeles Metropolitan Transportation Authority, the Ports of Los Angeles and Long Beach, the Southern California Association of Governments, and the Gateway Cities Council of Governments.

With two grants, totaling approximately \$14 million from the DOE's Zero Emission Cargo Transport (ZECT) Program, the SCAQMD has engaged leading EV integrators, including BAE Systems, Transportation Power (TransPower) and US Hybrid, as well as a major truck manufacturer, Kenworth, to develop and demonstrate a variety of Class 8 electric drayage trucks, consisting of eleven zero emission trucks – six battery electric and five fuel cell trucks – and seven hybrid electric trucks with extended range using CNG, LNG or diesel ICEs. These trucks

are deployed in real world drayage operations to evaluate the trucks' performance and capability as well as to identify limitations in supporting demanding drayage duty cycles. To date, five battery electric trucks (BETs) have been completed and deployed in field demonstration with drayage fleets at the Ports. With an estimated range of 80 to 100 miles per charge, these BETs are deployed in near-dock and local operations within a 20-mile radius from the Ports and have been providing dependable service with positive feedback from fleet drivers on its quiet and smooth operations with sufficient power and torque. In addition, one CNG plug-in hybrid electric truck (PHET), with 30-40 miles in all-electric range (AER) and 150-200 miles of total operating range, is currently undergoing final validation testing before deployment and four more trucks, including two fuel cell trucks with 150-200 miles of range, are expected to be completed in Q1 2017.



Figure 4: US Hybrid CNG PHET

Leveraging the technologies and expertise gained from the ZECT program, SCAQMD proposed and received a \$23.6 million grant from CARB under the Low Carbon Transportation Greenhouse Gas Reduction Fund (GGRF) Investment Program for a larger-scale demonstration of advanced electric drayage truck technologies in 2016. The project is to develop a portfolio of most commercially promising zero and near-zero emission drayage trucks for a statewide demonstration, across a variety of drayage applications in and around the Ports of Long Beach, Los Angeles, Oakland, Stockton and San Diego. SCAQMD has partnered with the four largest and most emission-impacted air districts in the state, namely Bay Area AQMD, Sacramento Metropolitan AQMD, San Joaquin Valley APCD and San Diego APCD, to build a comprehensive and coordinated approach to demonstrate the electric drayage trucks in diverse geographic and operational challenges across the state's interconnected goods movement system. For the project, the SCAQMD has successfully engaged three major truck OEMs – Kenworth, Peterbilt and Volvo, and an international OEM leader in heavy-duty electrification, BYD, to drive commercially-viable product development stages in a targeted portfolio of zero-emission and near-zero emission technologies and efficiency solutions, consisting of two battery-electric trucks, and two plug-in hybrid electric trucks with extended range capability, using natural gas or diesel ICEs, as follows:



Figure 5: TransPower Battery Electric Trucks



Figure 6: BYD T9 Prototype

BYD will develop 25 battery electric trucks based on their T9 prototype, which is optimized to serve near-dock and short regional drayage routes with a range of up to 100 miles. The truck is designed to provide similar operating experience compared to equivalent diesel and CNG trucks with matching or exceeding power and torque, using two 180 kW in-line traction motors.

Kenworth will develop four plug-in hybrid electric trucks with natural gas range extender, leveraging the prototype development under the ZECT program. These vehicles will target longer regional drayage routes, based a well-balanced blend of all electric and CNG-based hybrid operation to provide 250 miles in total operating range with a capability to operate 30-40 miles in zero emission mode in disadvantaged communities near ports, rail yards and distribution centers. The powertrain system includes a 200 kW genset using the recently certified 8.9L near-zero CNG engine and two AC traction motors, with comparable power output to Class 8 diesel trucks.

Peterbilt has partnered with TransPower to develop 12 battery electric drayage trucks, building on a platform developed under the ZECT program, incorporating lessons learned from ongoing demonstrations to further refine and optimize the electric drive system. Eight of the twelve trucks will be designed to provide up to 80-100 miles in range to support near-dock drayage routes, and four extended-range battery electric trucks will incorporate a new, higher energy density battery cells to provide up to 120-150 miles of operation to service regional drayage routes, such as from the San Pedro Bay Ports terminals to Inland Empire warehouses.

Volvo will build on the success of a past SCAQMD/DOE-funded project by focusing on efficiency and emission optimization of a commercially attractive, highly-flexible product, while ensuring zero emission miles for operations in the most heavily emissions-impacted communities. Furthermore, Volvo, in partnership with LA Metro, will also integrate ITS connectivity solutions, such as vehicle-to-infrastructure and vehicle-to-vehicle communications targeting dynamic speed harmonization and reduced idling, to reduce fuel use and emissions.



Figure 7: BYD T9 Prototype

This exceptional portfolio features demonstrations of truly commercial-pathway trucks. Highlighting the commercial path reality of this portfolio, the principal contractors are all major heavy-duty truck OEMs. This is significant because major OEMs can bring necessary engineering resources, manufacturing capability, and a distribution/service network to support the future commercialization of these demonstration vehicles. Our partnership also includes LA Metro's participation with ITS efficiency integration, electric utility participation, and 13 confirmed end-user fleets who are experienced with the specific challenges and opportunities associated with early technology integration efforts. The relationships and technologies in this project represent a culmination of years of experience: leading truck manufacturers, innovative large and medium suppliers, air quality management districts and industry groups all coordinated in a focused push to create OEM-quality, commercially-viable products that both reduce criteria and carbon emissions.

Develop, Integrate and Demonstrate Ultra-Low Emission Natural Gas Engines from On-Road Heavy-Duty Engines

Heavy-duty on-road diesel vehicles are currently one of the largest sources of NO_x emissions in the South Coast Air Basin. This source category is still projected to be one of the largest contributors to NO_x emissions, even as the legacy fleet of older and higher polluting vehicles are retired from operation and replaced by the vehicles meeting the most stringent emission levels required by 2010 emissions standards. NO_x reductions in excess of 50% will be needed from all source categories to meet future federal ambient air quality standards for ozone. Diesel engines have not achieved the necessary ultra-low emission levels. Natural gas engines, such as the Cummins Westport ISL-G NZ, have achieved a 90% reduction from the 2010 NO_x emission standard and are currently entering the market in new

transit buses, school buses, and medium-heavy duty trucks as an engine repower option for vehicles already equipped with 0.2 g/bhp-hr ISL-G engines. Near-zero NO_x emission engines are likely to be adopted sooner and at lower cost than possible with zero emission technologies since the near-zero engine technology is an evolution of existing natural gas engines that are in widespread use in many vehicle fleets.

SCAQMD, with funding from the California Energy Commission and the Southern California Gas Company, supported development of the 8.9-liter Cummins Westport engine and a new 15-liter natural gas engine from Cummins, Inc., that could meet a target of 0.02 g/bhp-hr NO_x. The engines cover a range of power and vehicle applications that represent a significant fraction of the on-road heavy duty vehicle population. In 2015, the Cummins Westport 8.9-liter ISL-G NZ (near zero) engine was certified by CARB as meeting the Optional 0.02 g/bhp-hr NO_x standard. The 15-liter Cummins engine also achieved the Optional 0.02 g/bhp-hr NO_x standard but it was not certified or introduced into commerce due to high capital cost of building a new engine and current limited demand. The technology, drawing from light duty natural gas engines, and optimized with extensive computer simulations and engine testing was shown to offer improved performance, fuel efficiency, and emissions compared to other heavy-duty natural gas engines that were derived from diesel engine platforms. The Cummins technology is scalable over an 8-15-liter engine size range and will be incorporated in any new natural gas engine introduced by Cummins.

In 2015, SCAQMD with funding from the Southern California Gas Company, awarded a contract for development of an 8.8-liter V-8 natural gas engine derived from a gasoline engine design. This engine was expected to be a better fit in light-heavy duty or medium duty conventional pick-up and van chassis than engines derived from diesel engines. The project team is led by the Gas Technology Institute and uses the Power Solutions International natural gas engine with ultra-low emission technology developed by Ricardo, Inc. Design work was completed in 2016. This project is now in the prototype fabrication stage with engine testing scheduled for 2017. At this time, the project does not include vehicle integration or an on-road demonstration.



Figure 8: Typical Heavy Duty Drayage Truck

In 2016 SCAQMD, with funding from the California Energy Commission, the Southern California Gas Company, and Clean Energy, Inc., awarded a contract to Cummins Westport to develop an ultra-low NO_x emission version of the 11.9-liter ISX12-G engine. This project will apply the engine and after-treatment technologies developed for the 8.9-liter ISL-G NZ engine to a larger engine better suited to drayage and regional goods movement than the ISL-G engine. Development is well underway with early Alpha prototype engines now entering the demonstration phase.



Figure 9: ISL-G Natural Gas Engine



Figure 10: 8.8-Liter PSI Natural Gas Engine

Develop and Demonstrate Class 8 Fuel Cell Range-Extended Electric Drayage Truck

The I-710 and CA-60 highways are key transportation corridors in the Southern California region that are heavily used on a daily basis by heavy duty drayage trucks that transport the cargo from the ports to the inland transportation terminals. These terminals, which include store/warehouses, inland-railways, are anywhere from 5 to 50 miles in distance from the ports. The concentrated operation of these drayage vehicles in these corridors has had and will continue to have a significant impact on the air quality in this region whereby significantly impacting the quality of life in the communities surrounding these corridors. To reduce these negative impacts, it is critical that zero and near-zero emission technologies be developed and deployed in the region. A potential local market size of up to 46,000 trucks exists in the South Coast Air Basin, based on near-dock drayage trucks and trucks operating on the I-710 freeway.

Under project management by CTE, BAE Systems and Kenworth Trucks, this effort will develop a



Figure 11: Los Angeles-Goods Movement and Industrial Corridor

battery electric truck with a hydrogen range extender. This project will leverage the expertise of BAE Systems and Ballard Power Systems to test their hybrid electric fuel cell propulsion system, currently used for transit buses, in drayage applications. The power output of the electric drive train is comparable to currently used Class 8 truck engines power output. The vehicle will operate primarily from the batteries, engaging the fuel cell system only when the batteries reach a specified state of charge; BAE anticipates that the truck will provide approximately 112 miles of range between re-fueling.



Figure 12: Proposed Kenworth Truck Chassis

The primary objective for this project is to reduce criteria pollutants in the South Coast Air Basin by reducing diesel emissions from the transportation and movement of goods from the ports to intermodal and warehousing facilities throughout Southern California. Our technical objective is to accelerate the introduction and penetration of fuel cell technologies into the cargo transport sector, which will help achieve our primary objective to substantially reduce criteria pollutants, and as a side benefit, reduce petroleum consumption and greenhouse gases. Fuel cell range extenders, however, faces many challenges in the process of commercialization: proper sizing of the fuel cell stack,

battery and fueling system; system integration and packaging of power train components and systems for safe, efficient and economical deployment of the technology are just a few of the challenges.

The proposed project area is known as the Los Angeles Goods Movement and Industrial Corridor. This area is adjacent to the Ports of Long Beach and Los Angeles, the busiest port complex in North America. The area is also a known Environmental Justice Community made up of predominantly low-income and minority populations.

Develop and Demonstrate Fuel Cell Extended-Range Electric Medium-Duty Truck and Powertrain for Parcel Delivery Trucks

Transitioning to zero and near-zero emission vehicles is one of the objectives of the Draft 2016 AQMP control strategies to attain Federal air quality standards for the South Coast Air Basin. According to UPS their parcel delivery Class 6 truck chassis go through several diesel repowers during its lifecycle which improves the return on assets for the company. In the transition to zero emission vehicles in the medium duty vehicle sector repowering to electric would make both economic and environmental sense for parcel delivery services like UPS.

UPS and CTE have joined together to develop an electric van with a fuel cell range extender. CTE sought and received funding from the DOE and CEC for the development of a fuel cell walk-in van. These vans will have a smaller battery and a small fuel cell with hydrogen storage to meet the majority of range needs for UPS and also the ability to refuel with hydrogen quickly for longer routes.



Figure 13: UPS Truck Chassis for Conversion

The Fuel Cell Hybrid Electric Medium-Duty Truck project offers substantial air quality and other environmental benefits. The project will help eliminate criteria pollutant and greenhouse gas emissions with fuel cell hybrid electric parcel delivery trucks. Unlike typical EV deployments, which usually displace cleaner current year diesel engines through annual retirement and purchasing plans, this proposed project will

immediately terminate the use of a pre-2006 diesel engine that would otherwise continue to operate for many more years. The repowered vehicles will eliminate PM_{2.5} emissions completely, and will result in significant healthcare cost savings due to the elimination of harmful emissions throughout California communities.

This project is proposed in two-phases. In Phase 1, a pre-2006 model diesel-powered walk-in van will be converted to electric drive and then integrated with the fuel cell, power electronics, hydrogen storage system and controls. If the performance specifications are met and DOE approves Phase 2 will commence. In Phase 2, additional fuel cell hybrid walk-in vans will be built for operation under real-world conditions at UPS's distribution facilities in Northern California and in the South Coast Air Basin for at least 5,000 hours of operation. At least four of the vehicles will be deployed in the South Coast Air Basin. Any design updates will be incorporated due to lessons learned from the demonstration and validation phase.



Figure 14: Phase 1 Vehicle Modeling

In addition to co-funding the Fuel Cell Hybrid Electric Medium-Duty Trucks project, SCAQMD is also co-funding a related project with UPS and Calstart. That project seeks to develop a medium-duty fuel cell extended-range delivery truck with the fuel cell provided by another OEM for demonstration in parcel delivery services at the UPS Ontario Regional Hub. The demonstration project will validate the performance and reliability of a fuel cell hybrid electric powertrain, as well as to assess its commercial viability in urban delivery operations.

Technology Deployment and Commercialization

One function of the Clean Fuels Program is to help expedite the deployment and commercialization of low and zero emission technologies and fuels needed to meet the requirements of the AQMP control measures. In many cases, new technologies, although considered “commercially available,” require assistance to fully demonstrate the technical viability to end-users and decision-makers.

The following projects contracted during the CY 2016 reporting period illustrate the impact of the SCAQMD's technology deployment and commercialization efforts and include: (a) construction of renewable natural gas production facilities and vehicle demonstrations; (b) hydrogen infrastructure rollout efforts throughout the year; and (c). electric/hybrid vehicle and infrastructure deployment and commercialization efforts in 2016.

Alternative Renewable Natural Gas (RNG) Fuel Development, Demonstration and Deployment

Air quality in the South Coast Air Basin (SCAB) is significantly impacted by emissions from on-road heavy-duty vehicles (HDVs). These vehicles consume significant amounts of fossil fuel which contribute to local NO_x and PM emissions as well as GHG emissions. Near-zero NO_x natural gas engines fueled with renewable natural gas (RNG) provide a commercially proven and cost effective strategy to reduce NO_x emissions in the near term as well as help reduce GHG emissions from U.S. on-road HDVs. The development and use of RNG as a transportation fuel also helps to solve additional California goals including the 50% Renewable Portfolio Standard, the Low Carbon Fuel Standard, and the 75% diversion of organics from landfills. Locally produced and consumed RNG helps to reduce emissions of methane associated with out-of-state natural gas, and its transportation and distribution. Finally, as a transportation fuel, RNG has the lowest carbon intensity of all the heavy-duty, internal combustion engine-driven truck pathways. Three contracts executed in 2016 are contributing to the local production and use of RNG as a transportation fuel, demonstrating the use of RNG in near-zero NO_x emission heavy-duty vehicles, and providing greater public awareness of CNG and RNG as a viable and cost effective transportation fuel.

CR&R Incorporated Environmental Services' (CR&R) Anaerobic Digestion and Biomethane Facility (ADBF) in Perris, CA is a large scale biomass to renewable natural gas (RNG) production project located in the South Coast Air Basin. The CR&R ADBF is designed to be constructed in four phases and has received financial support from the California Energy Commission and Cal Recycle to implement Phases 1 and 2. CR&R's ADBF is deemed a "zero-waste" operation by the waste collection industry as it produces no waste products. The anaerobic digesters convert the biomass feedstock into gases that are conditioned to pipeline quality methane, and the remaining solids and liquids are returned into the carbon cycle as compost, soil amendment and fertilizer to help promote new plant growth and animal feed, and other related organics that can result in new biomass feedstock. The vehicles used to collect the feedstock are powered with the RNG produced at the ADBF to collect additional feedstock, closing a renewable biofuel cycle and reducing or eliminating the use of fossil-based CNG in this cycle. Nationally and globally, using locally produced RNG as a transportation fuel displaces petroleum-based or fossil based transportation fuels, reduces GHGs, and helps address transmission-related emission impacts from out-of-state produced natural gas and its transportation and pipeline distribution.

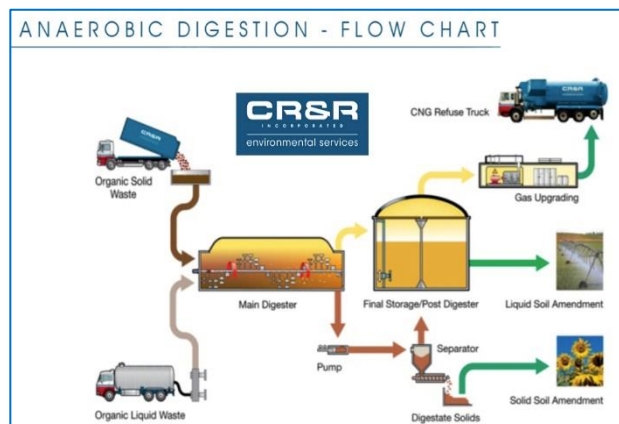

Figure 15: CR&R's Anaerobic Digestion Flow Chart

The contract with CR&R is to support the second phase of four phases of the ADBF, the production of RNG in excess of CR&R's fleet demand, the introduction of pipeline quality RNG into the Southern California Gas Company's natural gas grid, and the demonstration of RNG in near-zero NOx emission heavy-duty natural gas engines that meet or exceed CARB's Optional Low-NOx Standard. CR&R's ADBF will convert high solids organic waste from residential and commercial refuse and green wastes into RNG and soil amendments and fertilizers. The contract will also demonstrate the use of this local RNG in at least two different near-zero emission on-road heavy-duty solid waste collection type vehicles. The vehicles will be owned and operated by CR&R and will be powered by the 8.9L Cummins Westport (CW) ISL G NZ that is currently CARB certified to 0.02gNOX/bhp-hr. This engine is used in many curbside collection vehicles. The other engine is expected to be the CW 11.9L ISX12 G NZ that is being developed for CARB certification to same Optional Low NOx Standard as the ISL G NZ. The larger engine is used in transfer trucks. These "demonstration vehicles" will be deployed into CR&R's fleet and will perform routine solid waste collection services in the SCAB and provide reporting information on various performance parameters.

The CR&R ADBF project will help expand the production of locally produced RNG. Each phase of the ADBF is expected to produce 890,000 diesel gallon equivalents (DGE) of RNG annually. The expected goals of this project include the completion of Phase 2, the doubling of RNG production (from Phase 1), the demonstration of this fuel in a minimum of two near-zero emission heavy-duty natural gas powered refuse collection vehicles, and the successful introduction of RNG into the local natural gas pipeline grid.



Figure 16: CR&R's Anaerobic Digester

of the ADBF is expected to help State programs such as AB 32 by reducing an estimated 15,000 metric tons per year of greenhouse gases (GHGs) that can be attributed to decomposition of these organic

wastes in landfills and, recently adopted legislations, AB1826 and AB1594, which require diverting organic waste from landfills and directing this waste product to recycling operations.

KORE Infrastructure, LLC recently completed a six year pilot program with the Los Angeles County Sanitation District (LACSD) to develop a biosolids to renewable biofuels process. KORE's proprietary system uses pyrolysis to thermochemically decompose the organic materials from partially treated waste water it receives from public owned treatment works (POTW), into syngas and biochar. The syngas comprised of hydrogen, carbon monoxide, carbon dioxide, and methane is catalytically and chemically reformed into biofuel such as renewable natural gas (RNG) and the resulting solids, known as biochar (carbon), is used as a soil amendment.



Figure 17: KORE Pyrolysis Unit

This project supports the construction, operation, and production of a commercial scale Biosolids to Transportation Fuel (BTF) facility in the City of Rialto, CA. KORE will design, construct and operate the BTF based on the extensive work and data collected in the pilot program with LACSD. Due to its location, the feedstock will be transported by truck from the POTW to the BTF where it will be received in an odor controlled solids handling area. The feedstock will be partially heated to remove moisture prior to being transferred into the pyrolysis chamber where indirect heat at high temperature and low vacuum to produce the pyrogas and solid biochar. The pyrogas is cleaned and conditioned to remove contaminants, resulting in a cleaned syngas. The cleaned syngas is upgraded to RNG via a methanation process that combines the carbon monoxide, carbon dioxide, and hydrogen into CH₄ or RNG. The RNG is then compressed and stored or consumed as a transportation fuel or injected into the natural gas pipeline. Offtake agreements including injection into the pipeline grid and biochar distribution are to be defined under this contract. This project will also demonstrate the use of locally produced RNG as transportation fuel in conventional and near-zero NO_x CNG-powered vehicles. KORE will demonstrate the RNG in two of its natural gas-powered heavy-duty vehicles, each vehicle to have engines and exhaust system certified by the California Air Resources Board (CARB) to a NO_x emission standard equal to or less than 0.02gNO_x/bhp-hr. The KORE project is expected to produce up to 1,000 gasoline gallon equivalents (GGE) of RNG per day.



Figure 18: Methanation

Ontario CNG Station, Inc. (Ontario CNG) is a public access fueling facility located adjacent to the Ontario International Airport and the I-10 freeway corridor. The facility has all the appearances, amenities and visibility of a retail conventional fuel station. It is located at a well-travelled intersection and has driveway access from both from Vineyard Ave. and E. Holt Blvd. The facility sits on 53,000 square feet of property and has four fueling islands, a 24 hour per day / 7 day per week manned convenience store, restrooms, and a car wash giving consumers a conventional



Figure 19: Ontario CNG Station

fueling experience. Retail fuels that are sold at this facility include gasoline and diesel, renewable diesel, CNG/RNG (with RNG incorporated into the supply), hydrogen and electric vehicle charging ports. Two of the four fueling islands are dedicated to conventional fuels and renewable diesel. The other two islands have a total of four CNG dispensers and one hydrogen fuel dispenser. This project will also introduce RNG to Ontario CNG and requires a minimum of 240,000 GGE of renewable natural gas (RNG) annually for three years. The hydrogen fuel will be produced on-site by an electrolysis system funded through the CEC and the SCAQMD. Adjacent to the convenience store is one DC Fast charger and two Type 2 electric chargers. Funding support for the EV system is from the CEC. The 9,000 square feet of canopy covering the fueling islands will be equipped with electric photovoltaic solar panels to help offset electricity usage. The large area and multiple fueling island design of the station provide easy access to motorists, particularly long-haul tractor trailer rigs.

As a business model, Ontario CNG believes co-locating alternative fuels with conventional fuels in a conventional and familiar retail setting helps attract customers and also allows the business to be price competitive and profitable. In addition, co-locating alternative fuels with conventional fuels helps bring greater awareness of alternative fuels to the general public.

The objective of this contract is to successfully implement the expansion of CNG/RNG fueling at a public access, multi-fuel retail station in Ontario, California near the well-travelled Interstate 10 freeway and the Ontario International Airport. The location of this station will provide incentive for goods movement operators, municipal fleets, school districts and private fleet operators to adopt or expand the use of natural gas vehicle technology. This project will support increasing CNG/RNG fuel capabilities and fuel delivery systems, particularly for heavy duty Class 7 and 8 vehicles, and introduce the use and dispensing of renewable natural gas at this station.



Figure 20: Class 8 and MDV CNG Refueling

This contract will result in doubling on-site CNG/RNG compression to 972 cfm, doubling the number of dispensers to four and expanding on-site CNG/RNG storage by 36,000scf. The two new fast-fill dispensers each have two fuel hoses that dispense CNG/RNG at

3600

psig; two of the four CNG/RNG dispensers have one hose that employ a high flow Type 2 nozzle that is specifically designed to fuel heavy-duty long range tractor trailer vehicles which typically have 150 GGE of on-board storage. The expected result of this station design and equipment selection is a faster and more efficient refueling experience for all CNG vehicle operators.



Figure 21: CNG Storage Spheres

Hydrogen Infrastructure Rollout Efforts throughout 2016

For 2016, the SCAQMD continued to identify the development and deployment of hydrogen infrastructure as one of the agency's top priorities in order to attain federal air quality standards. Hydrogen infrastructure is consistent with the Passenger Transportation and Goods Movement White Papers developed for the Draft 2016 AQMP, which was adopted by the SCAQMD Governing Board on February 3, 2016; the goods movement strategy for zero emission trucks and infrastructure outlined in SCAG's 2016-2040 Transportation Systems/Goods Movement Appendix to the Regional Transportation Plan, and CARB's 2016 Mobile Source Strategy, adopted on May 16, 2016. Zero emission truck deployment is proposed through the year 2040 to meet goals outlined in SCAG's 2016-

2040 Regional Transportation Plan/Sustainable Communities Strategy, adopted in April 2016.

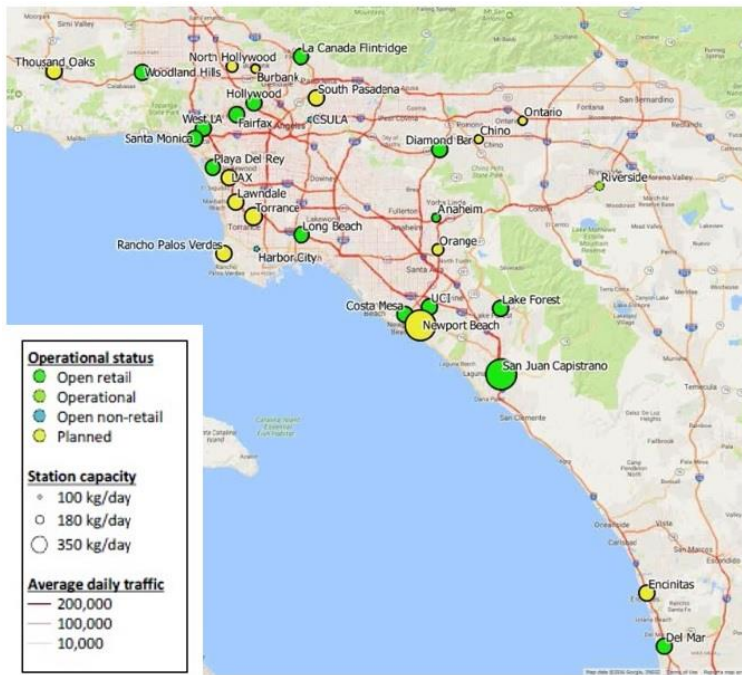

Figure 22: Hydrogen Infrastructure Rollout in the SCAQMD

Source: National Renewable Energy Laboratory

As part of the planned statewide rollout of new and upgraded hydrogen fueling stations, CEC and CARB released the annual Joint Agency Staff Report on Assembly Bill 8: 2016 Assessment of Time and Cost Needed to Attain 100 Hydrogen Refueling Stations in California (map above), describing 14 open retail stations, four open non-retail stations, and 14 stations and a temporary fueller in the process of being constructed and/or upgraded within the South Coast Air Quality Management District in the 2017-2018 timeframe. California as a whole has 25 retail hydrogen stations open from San Diego to San Francisco and Lake Tahoe. The newest rollout of hydrogen fueling stations are considered retail hydrogen stations because they are typically embedded within an existing gasoline station. Examples of recently opened retail hydrogen stations include Air Liquide system at the 76 station in Anaheim and the Linde system at the 76 station in San Juan Capistrano; retail stations to be opened in 2017-2018 include the Shell station in Torrance, 76 station in Ontario and Hyundai Chino station. Examples of retail hydrogen stations are shown in Figures 23–25. SCAQMD is cofunding, in conjunction with CEC (whose AB 118 dollars are the primary source of funding), most of the retail hydrogen stations under construction in our region, including FirstElement’s eight station contract and H2 Frontier’s temporary mobile fueller contract, both executed in 2016.



Figure 23: CDFA/DMS Testing Air Liquide System Co-located at Anaheim 76 station with NREL HyStEP Equipment



Figure 24: San Juan Capistrano Retail Hydrogen Station Co-located by Linde at 76 Gas Station

Linde delivers liquid hydrogen to the 350 kg/day hydrogen station in San Juan Capistrano, which is an example of the largest current capacity stations. SCAQMD cofunded the station development, originally to be located in Laguna Niguel. In early 2016, SCAQMD added cofunding to help address increased costs due to the site change.



Figure 25: FirstElement Retail Hydrogen Station Co-located at ARCO Gas Station in Long Beach

Following operation of the Burbank demonstration station through 2016 with SCAQMD funds as well as some financial assistance from CARB, which is described in more detail in the Key Projects Completed section, an upgrade of the Burbank station is planned as part of a larger \$6.69 million CEC grant for hydrogen upgrades including the upgrades of the Torrance and LAX stations to retail sales. As part of this CEC contract, funds for partial upgrade of the Mebtahi Chevron station in Harbor City were redirected to enable a more retail-oriented upgrade of the Burbank station, after Mebtahi was unable to execute their proposed upgrade contract.

Current retail hydrogen stations include point of sale (POS) dispensers capable of conducting retail transactions for the sale of hydrogen on a per kg basis using credit cards, and meet hydrogen quality, metrology and fueling protocols to ensure a safe, fast, full fill. Collectively, the stations would meet Renewable Portfolio Standard (RPS) requirements for providing hydrogen fuel with at least 33% renewable hydrogen. Some of the stations such as the Hyundai Chino station are designed to provide 100% renewable fuel. The renewable hydrogen requirement is fulfilled by solar, energy storage or renewable energy certificates, providing 100% renewable electricity to the station such as for local generation using an electrolyzer or reformer, or by the delivery of 33% or 100% renewable hydrogen produced by a central natural gas reformer, or by a mix of local generation and delivered hydrogen.

The California Department of Food and Agriculture, Division of Weights and Measures (DMS), must pre-certify POS dispensers so that stations can legally sell hydrogen by the kilogram to refuel fuel cell vehicles. DMS is continuing its metrology field testing effort on hydrogen dispensers in 2017.

Previously, U. S. DOE, along with automakers and other stakeholders, launched H2USA, a public-private partnership to address key challenges of hydrogen infrastructure. U. S. DOE, through H2First, a consortium of national labs, funded NREL to develop a new Hydrogen Station Equipment Performance (HyStEP) device to validate or audit fill performance of hydrogen stations to meet SAE J2601 light-duty fueling protocol using test method CSA HG V 4.3 under development. SCAQMD (with CARB, CEC, CaFCP and automakers) will be executing a contract in 2017 to support HyStEP to test stations in California.

Following completion of the 100% renewable non-retail hydrogen station at the Orange County Sanitation District facility in Fountain Valley which had been operated by Air Products and Chemicals,

Inc. from 2009 through 2015, SCAQMD is seeking partners and planning to support larger capacity hydrogen stations, including increasing production from renewable sources.

Previously, Energy Independence Now (EIN), in partnership with SCAQMD, completed a project to develop a Hydrogen Network Investment Plan (H2NIP) in order to examine market success factors relative to the looming launch of FCVs and support infrastructure.

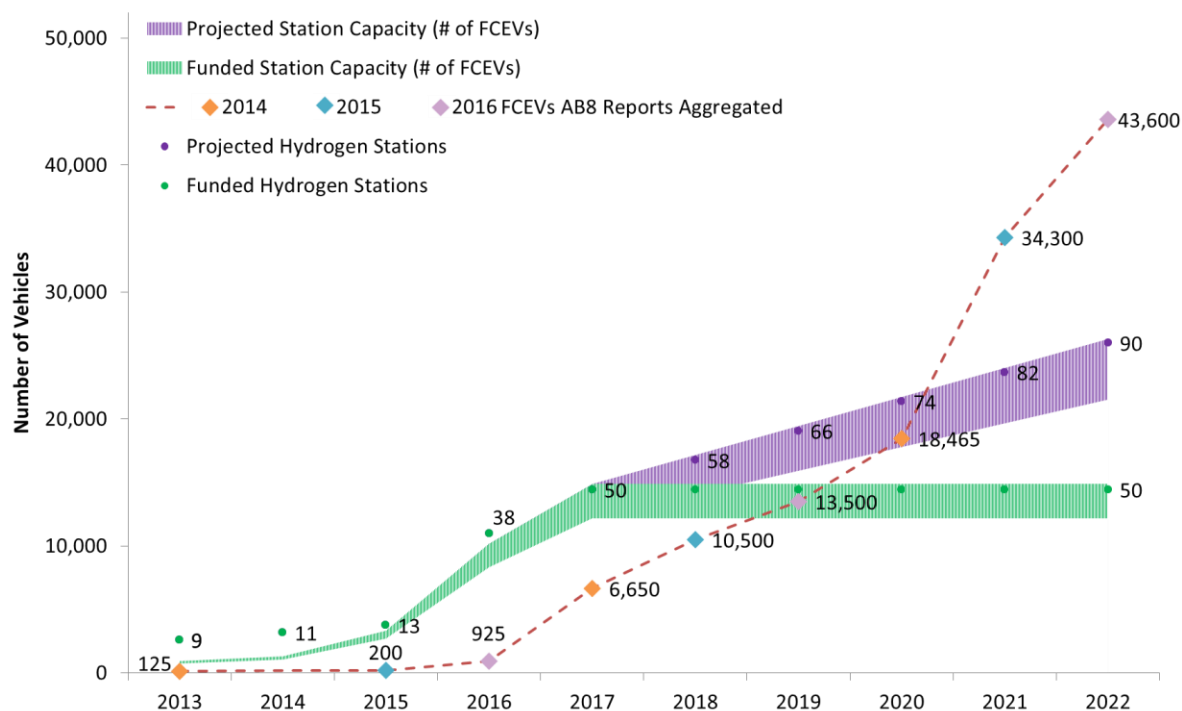

Figure 26: Station Shortfall Projection

Source: Joint Agency Staff Report on AB 8 released January 2017

Further research into renewable hydrogen pathways, economics and incentive structures is ongoing in order to establish and validate viable actions that stakeholders can take to ensure that the FCV community maximizes reductions in carbon emissions and other pollutants with adverse impacts to public well-being. This work is of critical importance in the developmental phase of support infrastructure.

Work conducted by EIN towards development of the H2NIP and effectiveness of incentives in the renewable hydrogen market was part of a larger hydrogen readiness project funded by CEC with the California Fuel Cell Partnership, “Hydrogen Readiness in Early Markets: Best Practices to Support the Introduction of Hydrogen Fuel Cell Vehicles in California”.

The hydrogen readiness project examined potential policy proposals, incentives and financing options, as well as looking at best practices, training to emergency responders, procurement strategies, education outreach and assessing hydrogen readiness in early market communities. The hydrogen readiness project was completed in 2016, and key recommendations included:

- Make hydrogen from renewable sources eligible for credits under California’s Low Carbon Fuel Standard. This will create an additional revenue stream to help producers cover costs.
- The average time to permit and build a hydrogen station has decreased significantly in just a few years. Shortening the process further is possible through improved understanding of codes and standards by authorities having jurisdiction.

- Station owners need succinct messaging about the benefits of adding a hydrogen fueling station and realistic information about the number of cars they can expect to fuel.
- For fire and safety training, train-the-trainer courses are vital for reaching all firefighters.
- Targeted messaging to ZEV buyers and fleet buyers will encourage increased adoption of FCEVs, and a wide-reaching awareness campaign will help other audiences select FCEVs for their future car purchase.
- Government and industry participation in stakeholder organizations is critical to reducing station costs and bringing more renewable hydrogen into the fuel supply.

The next couple of years should reveal huge strides in fuel cell vehicle technology and hydrogen infrastructure growth, and SCAQMD plans to continue to be a leader in this core technology.

Electric/Hybrid Vehicle and Infrastructure Deployment and Commercialization Efforts in 2016

The SCAQMD has identified the development and deployment of electric vehicle (EV) infrastructure as one of the agency’s top priorities in order to attain federal air quality standards. EV infrastructure is consistent with the goods movement strategy for zero-emission trucks and infrastructure proposed in SCAQMD’s 2017 *Air Quality Management Plan*, SCAG’s 2016 *Regional Transportation Plan* as well as the joint CARB, SCAQMD and SJVAPCD *Vision for Clean Air: A Framework for Air Quality and Climate Planning*. Zero-emission truck deployment is proposed through the year 2040 to meet goals outlined in the 2016 *Regional Transportation Plan/Sustainable Communities Strategy*.

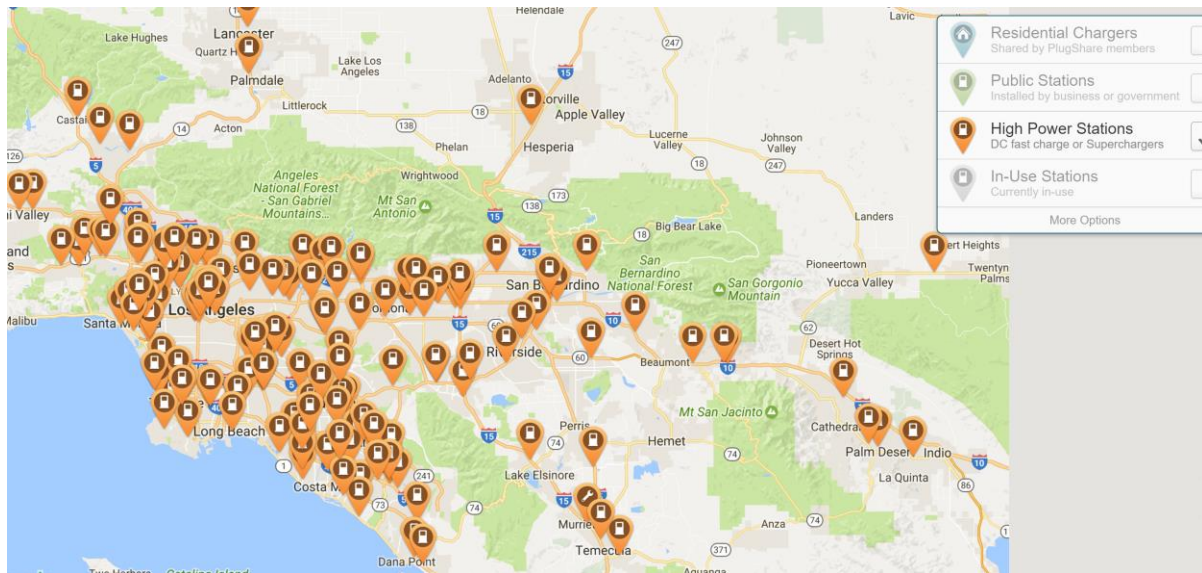

Figure 27: DC Fast Charging Station in SCAQMD

The California Public Utilities Commission has also recognized transportation electrification and recently permitted investor-owned utilities (e.g., Southern California Edison locally) to invest in charging infrastructure. California expects to be the largest U.S. market for Plug-In Electric Vehicles (PEVs), especially in the greater Los Angeles region with over 44% of the state’s population and a historic and ingrained car-centric culture. As part of the planned statewide rollout of new DC fast charging corridors funded by CEC (see Figure 28), there are 27 DC fast charging stations sited along major freeway corridors that have been completed or in the process of construction by CEC funded projects managed by SCAQMD in the 2017 timeframe. This will extend the growing DC fast charging corridor east and west to locations in the Coachella Valley, further connecting Los Angeles, San Diego, Santa Barbara and Palm Springs.



Figure 28: CEC Funded DC Fast Charging Corridors in SoCal

For this project SCAQMD is partnered with eVgo as the network provider who will own, operate and maintain the DC fast charging network; Clean Fuel Connection, Inc. as the installation partner; UCLA Luskin Center for Innovation who is responsible for site selection modeling; and Three Squares, Inc. who organizes press events and is designing an education outreach campaign targeted to EV drivers.

Site locations were selected using UCLA Luskin Center’s sophisticated PEV adoption modeling software that seeks to maximize charge station utilization by identifying travel patterns between census tracts where PEV drivers actually reside, work and shop. This is combined with land use data on local densities of workplaces, MUDs and retail establishments, data on pre-existing charging station locations. Finally, demographic data and the characteristics of the local transportation system are used as described in the *Southern California PEV Readiness Plan* (written by the UCLA Luskin Center and winner of the 2013 Planning Excellence Award by the Los Angeles section of the American Planning Association). Project partners also provided input on the site selection and site substitution process. The UCLA Luskin Center analyzed selected locations to maximize the effectiveness of the overall DCFC deployment.

Project sites were selected because these sites are situated alongside major freeways linking urban areas on heavily traveled routes and highly visible locations. The sites selected for the DC fast charging stations are in the parking lots of grocery stores or similar destinations. These are ideal locations for DC fast charging stations because the average consumer visiting a grocery store spends over 30 minutes shopping, which provides enough time for a complete charge. Chargers will provide 24-hour public access.

Examples of recently opened DC fast charging stations are located at the City of Calabasas City Hall (see Figure 29) and City of Palm Desert City Hall. An additional five DC fast charging stations will be installed by April 2017, and an additional 20 DC fast charging stations will be installed by December 2017. These DC fast charging stations are located throughout the four-county SCAQMD jurisdiction. Locations include the Cities of Moreno Valley, Palm Springs, Temecula, Monterey Park, and West Hollywood. Sites are part of the larger EVgo network and can be accessed using pay per use or subscription payment.



Figure 29: DC Fast Charging Station at City of Calabasas City Hall

Prior to each station opening, Three Squares will organize a custom press event to inform the public about the availability of a new DC fast charging station and educate consumers. Press events will take different formats based on the needs of each city. Below is a postcard advertising the grand opening of the DC fast charging station at the City of Calabasas City Hall, which took place in August 2016.

Figure 30: SoCalFast Education Outreach Campaign for PEV Drivers

Installation of EV Infrastructure at SCAQMD Headquarters

In September 2016, the Governing Board approved the execution of a contract with Clean Fuel Connection, Inc. to install Level 2 charging stations at the SCAQMD headquarters facility. Installation of charging stations took place in several phases.



Figure 31: Areas of EV Charger Installations at SCAQMD Headquarters

The first phase of installation of 36 Level 2 charging ports in the upper deck parking lot was completed in December 2016. An additional 25 level 2 charging ports were installed under the solar carport and upper deck in January 2017, to be followed by 15 charging ports in the CC8 parking lot and 12 charging ports in the front lobby/guest parking lot in spring 2017.



Figure 32: Installations in Progress

As part of this installation project, EV charger transactions and user notifications are managed through the Greenlots Sky networking software platform and data from the EV chargers are collected on the Greenlots network and will be shared with the future Siemens energy management system (EMS) that will be purchased and installed at SCAQMD headquarters. As part of the tie in with the building's EMS, electricity demand from the EV chargers can be ramped down or turned off in response to the building's overall demand and to avoid demand charges during peak hours in the summer months. The charging stations can be accessed through the Greenlots phone app or the RFID card and users will automatically be notified by text or email when a charging session starts, ends, is interrupted, ramped down, turned off, or subject to a different rate structure. Screens from the Greenlots phone app are shown below in Figure 33.

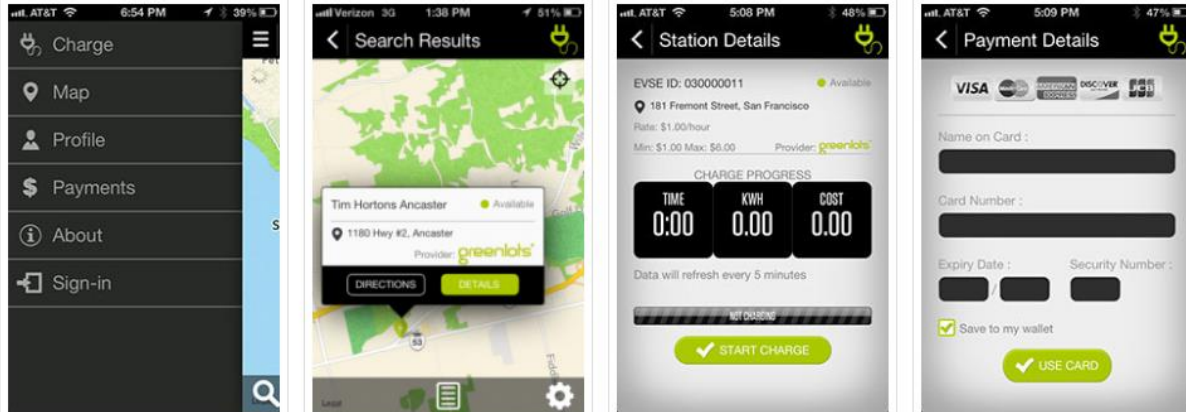

Figure 33: Greenlots Phone App and Networking Software

2016 FUNDING & FINANCIAL SUMMARY

The SCAQMD Clean Fuels Program supports clean fuels and technologies that appear to offer the most promise in reducing emissions, promoting energy diversity, and in the long-term, providing cost-effective alternatives to current technologies. In order to address the wide variety of pollution sources in the Basin and the need for reductions now and in the future, using revenue from a \$1 motor vehicle registration fee (see Program Funding on Page 5), the SCAQMD seeks to fund a wide variety of projects to establish a diversified technology portfolio to proliferate choices with the potential for different commercial maturity timing. Given the evolving nature of technology and changing market conditions, such a representation is only a “snapshot-in-time,” as reflected by the projects approved by the SCAQMD Governing Board.

As projects are approved by the SCAQMD Governing Board and executed into contracts throughout the year, the finances may change to reflect updated information provided during the contract negotiation process. As such, the following represents the status of the Clean Fuels Fund as of December 31, 2016.

Funding Commitments by Core Technologies

The SCAQMD continued its successful leveraging of public funds with outside investment to support the development of advanced clean air technologies. During the period from January 1 through December 31, 2016, a total of 66 contracts, projects or studies that support clean fuels were executed or amended, as shown in Table 2 (page 38). The major technology areas summarized are (listed in order of funding priority during the CY): engine systems, electric/hybrid technologies and infrastructure, fueling infrastructure and deployment, hydrogen and mobile fuel cell technology and infrastructure, engine systems, technology assessment/transfer and outreach, and fuels and emission studies. The distribution of funds based on technology area is shown graphically in Figure 34 (page 36). This wide array of technology support represents the SCAQMD’s commitment to researching, developing, demonstrating and deploying potential near-term and longer-term technology solutions.

The project commitments that were contracted or purchased for the 2016 reporting period are shown below with the total projected project costs:

• SCAQMD Clean Fuels Fund Contribution	\$21,760,365
• Total Cost of Clean Fuels Projects	\$198,190,157

Each year, the SCAQMD Governing Board approves funds to be transferred to the General Fund Budget for Clean Fuels administration. For 2016, the Board transferred \$1 million for workshops, conferences, cosponsorships and outreach activities as well as postage, supplies and miscellaneous costs for participation in special conferences. Only the funds committed by December 31, 2016, are included within this report. Any portion of the Clean Fuels Funds not spent by the end of Fiscal Year 2016-17 ending June 30, 2017, will be returned to the Clean Fuels Fund.

Partially included within the SCAQMD contribution are supplemental sponsorship revenues from various organizations that support these technology advancement projects. This supplemental revenue for pass-through contracts executed in 2015 totaling \$3.42 million is listed within Table 3 (page 41).

Appendix B lists the 93 Clean Fuels Fund contracts that were open and active as of January 1, 2017.

For Clean Fuels executed and amended contracts, projects and studies in 2016, the average SCAQMD contribution is approximately 11 percent of the total cost of the projects, identifying that each dollar from the SCAQMD was leveraged with more than \$9 of outside investment. The typical leverage amount is \$3-\$4 for every \$1 of SCAQMD Clean Fuels Funds, but 2016 notably had

several significant contracts, significant both in funding and in the impact they hopefully will make in strides toward developing and commercializing clean transportation technologies.

During 2016, the distribution of funds for SCAQMD executed contracts, purchases and contract amendments with additional funding for the Clean Fuels Program totaling approximately \$21.8 million are shown in Figure 34 below.

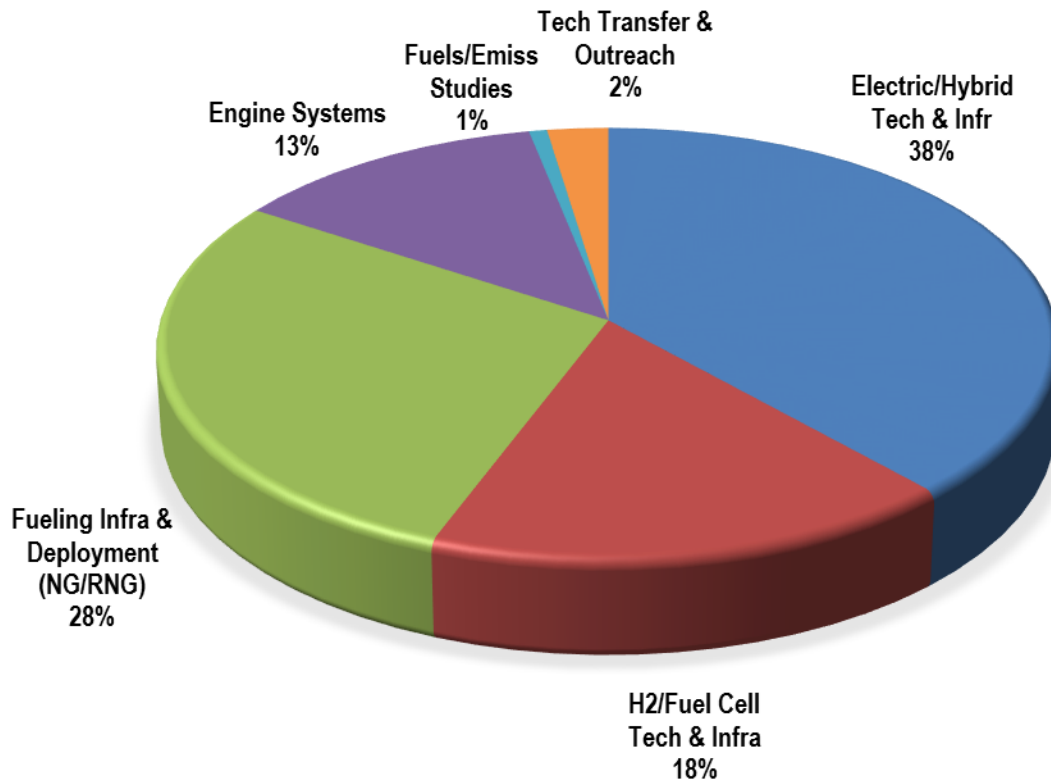

Figure 34: Distribution of Funds for Executed Clean Fuels Projects CY 2016 (\$21.8M)

Table 2 (page 38) provides a breakdown of this \$21.8 million in executed contracts. Table 3 (page 41) provides information on outside funding recognized and received into the Clean Fuels Fund (\$3.42 million) for contracts executed in CY 2016. Additionally, the SCAQMD continued to seek funding opportunities and Table 4 (page 41) lists the additional \$48.9 awarded in 2016 for projects that will be implemented as part of the Clean Fuels Program or which align well or will be complementary to the Clean Fuels Program.

Review of Audit Findings

State law requires an annual financial audit after the closing of each SCAQMD’s fiscal year. The financial audit is performed by an independent Certified Public Accountant selected through a competitive bid process. For the fiscal year ended June 30, 2016, the firm of Simpson and Simpson, CPAs conducted the financial audit. As a result of this financial audit, a Comprehensive Annual Financial Report (CAFR) was issued. There were no adverse internal control weaknesses with regard to SCAQMD financial statements, which include the Clean Fuels Program revenue and expenditures. Simpson and Simpson CPAs gave the SCAQMD an “unmodified opinion,” the highest obtainable. Notably, the SCAQMD has achieved this rating on all prior annual financial audits.

Project Funding Detail by Core Technologies

The 66 new and continuing contracts, projects and studies that received SCAQMD funding in 2016 are summarized in Table 2, together with the funding authorized by the SCAQMD and by the collaborating project partners.

Table 2: Contracts Executed or Amended (w/\$) between January 1 & December 31, 2016

Contract	Contractor	Project Title	Start Term	End Term	SCAQMD \$	Project Total \$
Hydrogen/Mobile Fuel Cell Technologies and Infrastructure						
12057	Linde, LLC	Expand Hydrogen Fueling Infrastructure	11/02/12	04/01/19	80,000	160,000
15618	FirstElement Fuel, Inc.	Installation of Eight Hydrogen Stations in Various Cities (two renewable, six delivered)	02/05/16	02/04/21	1,000,000	16,442,000
15635	Center for Transportation and Environment	ZECT II: Develop and Demonstrate One Class 8 Fuel Cell Range-Extended Electric Drayage Truck	04/27/16	10/26/20	821,198	7,109,384
16025	Center for Transportation and the Environment	Develop and Demonstrate Fuel Cell Hybrid Electric Medium-Duty Trucks	02/05/16	08/04/20	980,000	7,014,050
16251	H2 Frontier, Inc.	Develop and Demonstrate Commercial Mobile Hydrogen Fueler	05/06/16	05/05/21	200,000	1,665,654
17030	Bevilacqua-Knight, Inc.	Participate in California Fuel Cell Partnership for Calendar Year 2016 and Provide Support for Regional Coordinator	01/01/16	12/31/16	135,000	1,705,233
17059	Calstart Inc.	Develop and Demonstrate Fuel Cell Extended-Range Powertrain for Parcel Delivery Trucks	10/27/16	04/26/18	589,750	1,574,250

Electric/Hybrid Technologies and Infrastructure

13410	Selman Chevrolet Company	Lease Three 2013 Chevrolet Volt Extended-Range Electric Vehicles for Three Years Then Purchase Vehicles	04/03/13	04/02/16	84,450	84,450
13429	Longo Toyota	Lease One Toyota RAV4 Electric Vehicle for Three Years Then Purchase Vehicle	04/19/13	04/02/16	22,410	22,410
14184	Clean Fuel Connection, Inc.	DC Fast Charging Network Provider	04/04/14	06/30/20	920,000	1,153,880
16200	California State University Los Angeles	Cost-Share Regional Universities for U.S. DOE EcoCAR 3 Competition	04/14/16	04/15/20	100,000	800,000
16227	Selman Chevrolet Company	Lease One 2016 Chevrolet Volt Extended-Range Electric Vehicle for Three Years	02/01/16	01/31/19	15,677	15,677
16081	Broadband TelCom Power, Inc.	Provide EV Hardware and Control System at SCAQMD Headquarters including Installation Support, Warranty and Networking	04/27/16	04/26/22	367,425	367,425
17065	Clean Fuel Connection, Inc.	EV Infrastructure Installer	12/02/16	12/31/21	805,219	805,219

Table 2: Contracts Executed or Amended (w/\$) between January 1 & December 31, 2016

Contract	Contractor	Project Title	Start Term	End Term	SCAQMD \$	Project Total \$
----------	------------	---------------	------------	----------	-----------	------------------

Electric/Hybrid Technologies and Infrastructure (cont'd)

Transfer	Transfer from Clean Fuels	Zero Emission Drayage Truck Demonstration Project	03/04/16	03/04/16	6,001,531	40,122,470
Direct Pay	Clean Fuel Connection, Inc.	Electric Vehicle Supply Equipment Installation	01/01/16	02/29/16	20,677	20,677
Direct Pay	Southern California Edison	Short Circuit Study for Headquarters Electric Vehicle Infrastructure	01/01/16	01/01/16	400	400

Engine Systems

16205	Cummins Westport, Inc.	Develop, Integrate and Demonstrate Ultra-Low Emission 12-Liter Natural Gas Engines for On-Road Heavy-Duty Vehicles	06/03/16	06/30/18	2,750,000	6,250,000
-------	------------------------	--	----------	----------	-----------	-----------

Fueling Infrastructure and Deployment (NG/RNG)

16075	City of Desert Hot Springs	Purchase One Heavy-Duty CNG-Powered Truck	03/11/16	03/10/20	38,000	63,000
16244	CR&R, Inc.	Renewable Natural Gas Production and Vehicle Demonstration Project	09/03/16	03/02/20	900,000	55,000,000
16333	Ontario CNG Station, Inc.	Implement Alternative Fuel Station Expansion	05/13/16	11/12/19	200,000	798,535
17092	Kore Infrastructure, LLC	Construct RNG Production Facility and Demonstrate RNG with Next Generation Natural Gas Engine	10/14/16	10/13/21	2,500,000	25,500,000
Direct Pay	Varies	Cost-Share Local Match for 2015-16 Enhanced Fleet Modernization Program (EFMP) Plus-Up	01/08/16	01/08/16	1,033,500	8,100,500
Direct Pay	Varies	Purchase of Electric Leaf Blowers and Trimmers for Lawn and Garden Demonstration Program	03/31/16	03/31/16	4,195	4,195
Direct Pay	Varies	Cost-Share Local Match for 2016-17 Enhanced Fleet Modernization Program (EFMP) Plus-Up	09/02/16	09/02/16	1,503,000	18,209,000

Fuels/Emissions Studies

16198	Gladstein, Neandross & Associates, LLC	Study of Opportunities and Benefits of Deploying Next Generation Heavy-Duty Natural Gas Vehicles Operating on Renewable Natural Gas	09/02/16	09/02/16	50,000	250,000
16254	University of California Berkeley	Evaluate Ozone and Secondary Aerosol Formation from Diesel Fuels	10/25/16	08/31/17	106,361	106,361

Table 2: Contracts Executed or Amended (w/\$) between January 1 & December 31, 2016

Contract	Contractor	Project Title	Start Term	End Term	SCAQMD \$	Project Total \$
Fuels/Emissions Studies (cont'd)						
17060	University of California Riverside	Bailment Agreement for Equipment Use for In-Use Emissions Testing of Heavy-Duty Inspection and Maintenance Program	10/13/16	10/12/18	0	0
Technology Assessment/Transfer and Outreach						
08210	Sawyer Associates	Technical Assistance on Mobile Source Control Measures and Future Consultation on TAO Activities	02/22/08	02/28/18	10,000	10,000
17037	Clean Fuel Connection, Inc.	Technical Assistance with Alternative Fuels, Electric Vehicles, Charging and Fueling Infrastructure and Renewable Energy	11/18/16	11/17/18	50,000	50,000
17097	Gladstein, Neandross & Associates, LLC	Technical Assistance with Alternative Fuels and Fueling Infrastructure, Emissions Analysis and On-Road Sources	11/04/16	11/03/18	100,000	100,000
Direct Pay	Hartford/Alliant Insurance	Insurance for Alternative Fuel Vehicles in Technology Advancement Office's Fleet Demonstration Program	01/01/16	12/31/16	31,414	31,414
Transfer	Transfer from Clean Fuels	Participation in California Natural Gas Vehicle Partnership for Fiscal Year 2016-17 and 2017-18	07/08/16	07/08/16	25,000	236,872
Direct Pay	Transportation Research Board	Participation for Membership for July through December 2016	09/01/16	09/01/16	32,500	223,500
Direct Pay	Various	Cosponsor 24 Conferences, Workshops & Events plus 4 Memberships	01/01/16	12/31/16	282,658	4,300,523

Table 3: Supplemental Grants/Revenue Received into the Clean Fuels Fund (31) in CY 2016

Revenue Agreement #	Revenue Source	Project Title	Contractor	SCAQMD Contract #	Award Total \$
16217	Southern California Gas Company	Develop, Integrate and Demonstrate Ultra-Low Emission 12L Natural Gas Engines for On-Road Heavy-Duty Vehicles	Cummins Westport Inc.	16205	1,000,000
14051	California Energy Commission	DC Fast Charging Network	Clean Fuel Connection, Inc.	14184	420,000
15441	California Energy Commission	DC Fast Charging Network	Clean Fuel Connection, Inc.	14184	500,000
Transfer	BP ARCO Settlement Agreement Fund (46)	Construction of an RNG Production Facility in Rialto and Demonstration of RNG with Next Generation Natural Gas Engines	KORE Infrastructure, Inc.	17092	1,500,000
<i>Table 4 lists revenue recognized by SCAQMD into the Clean Fuels Fund (31) only if the pass-through contract was executed during the reporting CY (2016).</i>					3,420,000

Table 4: Summary of Federal, State and Local Funding Awarded or Recognized in CY 2016

Awarding Entity or Program	Award or Board Date	Purpose	Contractors	Award Total \$/Fund
CARB's Low Carbon Transportation GGRF	01/12/16	Zero Emission Drayage Truck Demonstration	BYD Motors, Kenworth Truck Company, Peterbilt Motors, & Volvo Technology of America	23,658,500 Fund 67
Bay Area AQMD	03/04/16	Zero Emission Drayage Truck Demonstration	BYD Motors, Kenworth Truck Company, Peterbilt Motors, & Volvo Technology of America	3,000,000 Fund 67
San Joaquin Valley APCD	03/04/16	Zero Emission Drayage Truck Demonstration	BYD Motors, Kenworth Truck Company, Peterbilt Motors, & Volvo Technology of America	1,000,000 Fund 67
San Diego APCD	03/04/16	Zero Emission Drayage Truck Demonstration	BYD Motors, Kenworth Truck Company, Peterbilt Motors, & Volvo Technology of America	200,000 Fund 67
San Diego Gas & Electric	03/04/16	Zero Emission Drayage Truck Demonstration	BYD Motors, Kenworth Truck Company, Peterbilt Motors, & Volvo Technology of America	200,000 Fund 67

**Table 2: Contracts Executed or Amended (w/\$) between January 1 & December 31, 2016
(cont'd)**

Awarding Entity or Program	Award or Board Date	Purpose	Contractors	Award Total \$/Fund
California Energy Commission	04/01/16	On-Road In-Use Emissions Testing and Usage Assessment	University of California Riverside & West Virginia University	2,000,000 Fund 31
Southern California Gas Company	04/01/16	On-Road In-Use Emissions Testing and Usage Assessment	University of California Riverside & West Virginia University	500,000 Fund 31
U.S. Environmental Protection Agency	06/03/16	Develop and Demonstrate Ultra-Low Emission Natural Gas Switcher Locomotive	VeRail	500,000 Fund 31
Southern California Gas Company	06/03/16	Develop and Demonstrate Ultra-Low Emission Natural Gas Switcher Locomotive	VeRail	500,000 Fund 31
CARB	09/02/16	On-Road In-Use Emissions Testing and Usage Assessment	University of California Riverside & West Virginia University	150,000 Fund 31
CARB/BAR	09/02/16	FY 2016-17 Implementation of the Retire and Replace Component of Enhanced Fleet Modernization Program	Various	3,700,000 Fund 56
CARB	09/02/16	FY 2016-17 Implementation of the Retire and Replace Component of Enhanced Fleet Modernization Program (EFMP) Plus-Up	Various	10,000,000 Fund 56
California Energy Commission	10/07/16	Develop, Integrate & Demo Ultra-Low Emission 12L NG Engines for On-Road Heavy-Duty Vehicles	Cummins Westport, Inc.	1,000,000 Fund 31
U.S. EPA 2016 Targeted Air Shed Grant	11/17/16	Battery Electric Yard Tractors Replacement Project	Westside Basin Container Terminal	2,477,250 Fund 17
<i>Table 5 provides a comprehensive summary of revenue awarded to SCAQMD during the reporting CY (2016) if it will be considered part of, or complementary to, the Clean Fuels Program, regardless of whether the pass-through contract has been executed.</i>				48,885,750

Project Summaries by Core Technologies

The following represents summaries of the contracts, projects and studies executed, or amended with additional dollars, in 2016. They are listed in the order found in Table 2 by category and contract number. The summaries provide the project title, contractors and subcontractors, SCAQMD cost-share, cosponsors and their respective contributions, contract term and a description of the projects as required by H&SC Section 40448.5.1(d).

Hydrogen and Mobile Fuel Cell Technologies and Infrastructure

12057: Expand Hydrogen Fueling Infrastructure

Contractor: Linde, LLC	SCAQMD Cost-Share	\$ 80,000
	Cosponsor	
	Linde	80,000
Term: 11/02/12 – 04/01/19	Total Cost:	\$ 160,000

Linde, LLC, was originally awarded funding to demonstrate that hydrogen fueling can be successfully integrated with retail gasoline fueling stations in Laguna Niguel, an area identified by the OEMs as an early adopter location. A new site in another city but still within Orange County had to be identified after negotiations with the original site owner fell through. An amendment was executed in early 2016 to address additional permitting and local jurisdictional requirements as well as higher project costs relating to the site location change. The project timeline was also modified to provide for three years of operational reporting. The SCAQMD and Linde, LLC, equally cost-shared the higher project costs and the hydrogen station is now commissioned and in operation.

15618: Installation of Eight Hydrogen Stations in Various Cities (two renewable, six delivered)

Contractor: FirstElement Fuel, Inc.	SCAQMD Cost-Share	\$ 1,000,000
	Cosponsor	
	California Energy Commission	11,608,000
	FirstElement Fuel, Inc.	3,834,000
Term: 02/05/16 – 02/04/21	Total Cost:	\$ 16,442,000

First Element submitted a proposal dated February 14, 2014 to CEC's PON-13-607. CEC is providing the majority of funding with co-funding from SCAQMD to install eight public access hydrogen fueling stations in the following cities: South Pasadena, Los Angeles (2 stations), Long Beach, Costa Mesa, La Canada Flintridge, Laguna Niguel and Lake Forest. Six of the stations shall have hydrogen delivered with 33% renewable content, and the remaining two stations shall have 100% renewable hydrogen delivered. The fueling stations shall be capable of delivering up to 100 kg of hydrogen per day nominal capacity, be able to fuel multiple vehicles back to back without delay to avoid congestion, and provide data according to the template in the NREL Data Collection Tool approved by CEC.

15635: ZECT II: Develop and Demonstrate One Class 8 Fuel Cell Range-Extended Electric Drayage Truck

Contractor: Center for Transportation and the Environment	SCAQMD Cost-Share	\$ 821,198
	Cosponsor	
	Department of Energy <i>(previously received as pass-through funds into Fund 61)</i>	3,554,691
	California Energy Commission <i>(previously received as pass-through funds into Fund 61)</i>	2,400,000
	Ports TAP Program <i>(previously received as pass-through funds into Fund 61)</i>	283,495
	Center for Transportation and the Environment	50,000
Term: 4/27/16 – 10/26/20	Total Cost:	\$ 7,109,384

Under project management by CTE, BAE Systems will develop a battery electric truck with a hydrogen range extender. This project will leverage the expertise of BAE Systems and Ballard Power Systems to test their hybrid electric fuel cell propulsion system, currently used for transit buses, in drayage applications. The power output of the electric drive train is comparable to currently used Class 8 truck engines power output. AC traction motors will be mounted one on each rear drive axle and the electric drive train in the architecture is set up to be fully redundant. The vehicle will operate primarily from the batteries, engaging the fuel cell system only when the batteries reach a specified state of charge. BAE anticipates that the 30 kg of hydrogen (25 kg usable) will provide approximately 112 miles of range between re-fueling.

16025: Develop and Demonstrate Fuel Cell Hybrid Electric Medium-Duty Trucks

Contractor: Center for Transportation and the Environment	SCAQMD Cost-Share	\$ 980,000
	Cosponsors	
	Department of Energy	2,857,560
	United Parcel Service	2,076,490
	California Energy Commission	1,100,000
Term: 02/05/16 – 08/04/20	Total Cost:	\$ 7,014,050

The Fuel Cell Hybrid Electric Walk-In Van Deployment Project is proposed in two phases. In Phase 1, CTE along with its vehicle integrators will demonstrate and validate lead final analysis and design for integration of the fuel cell power train into a base electric utility vehicle. A pre-2006 model diesel-powered walk-in van provided by UPS will be converted to electric drive by one of CTE's vehicle integrators, and this base electric vehicle will be shipped to their fuel cell system integrator who will integrate the Hydrogenics fuel cell, power electronics, hydrogen storage system and controls into the electric van. At the end of Phase 1, there will be a go/no-go decision made by the DOE. If the performance specifications have been proven, CTE will request approval from DOE to initiate Phase 2-Deployment. In Phase 2, up to 17 additional fuel cell hybrid walk-in vans will be built for operation

under real-world conditions at UPS distribution facilities in Sacramento and the South Coast Air Basin for at least 5,000 hours. Up to six of the vehicles will be deployed in the South Coast Air Basin. These vehicles will also be converted from pre-2006 model diesel-power UPS vans. Any design updates will be incorporated due to lessons learned from the demonstration and validation phase.

16251: Develop and Demonstrate Commercial Mobile Hydrogen Fueler

Contractor: H2 Frontier, Inc.	SCAQMD Cost-Share	\$ 200,000
	Cosponsors	
	California Energy Commission	999,677
	U.S. Hybrid	375,913
	H2 Frontier, Inc.	75,000
	Gas Technology Institute	15,064
Term: 05/06/16 – 05/05/21	Total Cost:	\$ 1,665,654

To ensure customers can continue to fuel at the hydrogen stations being upgraded in the Basin, CEC through PON 13-607 awarded Gas Technology Institute (GTI) \$999,677 to develop and demonstrate a commercial temporary hydrogen fueler, which would be used during upgrade transitions and temporary dispensing issues. GTI has partnered with U.S. Hybrid and H2 Frontier, Inc. The temporary fueler can be a stand-alone unit for remote filling or integrated into stations experiencing temporary dispensing issues during transition to upgraded equipment or repairs. The fueler will connect to the onsite hydrogen storage supply and have the ability to connect with existing hydrogen dispensers to fill onboard storage. It will use renewable fuel if possible and would be deployed at hydrogen stations as needed. SCAQMD is providing additional co funding to H2 Frontier, Inc.

17030: Participate in California Fuel Cell Partnership for Calendar Year 2016 and Provide Support for Regional Coordinator

Contractor: Bevilacqua-Knight, Inc.	SCAQMD Cost-Share	\$ 135,000
	Cosponsors	
	SCAQMD (in-kind)	10,440
	7 automakers, 6 public agencies, 2 industry stakeholders, 25 Full & Associate Members	1,559,793
Term: 01/01/16 – 12/31/16	Total Cost:	\$ 1,705,233

In April 1999, the California Fuel Cell Partnership (CaFCP) was formed with eight members; SCAQMD joined and has participated since 2000. The CaFCP and its members are demonstrating and deploying fuel cell passenger cars and transit buses with associated hydrogen fueling infrastructure in California. Since the CaFCP is a voluntary collaboration, each participant contracts with Bevilacqua-Knight, Inc. (BK) for their portion of the CaFCP's administration. In 2016, the SCAQMD Governing Board contributed \$85,000 for membership and up to \$50,000, along with four cubicles at SCAQMD Headquarters, to provide support for the CaFCP Regional Coordinator.

17059: Develop and Demonstrate Fuel Cell Extended-Range Powertrain for Parcel Delivery Trucks

Contractor: Calstart	SCAQMD Cost-Share	\$ 589,750
	Cosponsors	
	United Parcel Service	749,500
	Unique Electric Solutions, LLC	165,000
	Calstart	70,000
Term: 10/27/16 – 04/26/18	Total Cost:	\$ 1,574,250

UPS and CALSTART, together with engineering/technical lead UES and project team CCW, Nuvera and Nidec, will integrate, validate and demonstrate a commercial-path, optimized Fuel Cell Range Extended Electric Delivery Truck (FCXRDT) for demonstration out of the UPS Ontario Regional Hub and using hydrogen fueling available near the facility. The project team will integrate an electric driveline, consisting of a 120 kilowatt electric motor and 45-60 kWh battery pack together with a 30kW fuel cell and roughly 10kg of hydrogen storage onto an existing UPS Class 6 delivery truck. The resulting vehicle should demonstrate a daily guaranteed range of 125 miles, 65mph top speed and diesel-equivalent or better driving performance, all with zero emissions. The project leverages in excess of \$900,000 of UPS and partner investment and commitment to bring this complete driveline to the road.

Electric/Hybrid Technologies and Infrastructure

13410: Lease Three 2013 Chevrolet Volt Extended-Range Electric Vehicles for Three Years then Purchase Vehicles

Contractor: Selman Chevrolet Company	SCAQMD Cost-Share	\$ 84,450
Term: 04/03/13 – 04/02/16	Total Cost:	\$ 84,450

The SCAQMD operates a number of alternative fuel vehicles (AFVs) including electric vehicles (EVs), fuel cell vehicles (FCVs) and plug-in hybrid electric vehicles (PHEVs). The primary objective of having these vehicles as part of the SCAQMD's Fleet Demonstration Program is to continue to support the use of zero emission vehicles and bring awareness to the public of their viability. In 2016 this lease was modified to provide for the purchase of the three 2013 Chevrolet Volts, adding them permanently to the Fleet Demonstration Program and ensuring the green carpool stickers could continue to be utilized when out in the community.

13429: Lease One Toyota RAV4 Electric Vehicle for Three Years then Purchase Vehicle

Contractor: Longo Toyota	SCAQMD Cost-Share	\$ 22,410
Term: 04/03/13 – 04/02/16	Total Cost:	\$ 22,410

As noted, the SCAQMD operates a number of AFVs in its Fleet Demonstration Program to support the use of zero emission vehicles and bring awareness to the public of their viability. Toyota used 40 kWh Tesla battery packs for this 5-passenger mid-sized SUV, providing the second longest-range BEV in 2012 for a modest price. In 2016 this lease for one Toyota RAV4 EV was modified to provide for the purchase of the vehicle, adding it permanently to the Fleet Demonstration Program and ensuring the white carpool sticker could continue to be utilized when out in the community.

14184: DC Fast Charging Network Provider

Contractor: Clean Fuel Connection, Inc.	SCAQMD Cost-Share (received as pass-through funds)	\$ 920,000
	Cosponsor	
	eVgo	233,880
Term: 04/04/14 – 06/30/20	Total Cost:	\$ 1,153,880

Clean Fuel Connection, Inc. (CFCI) was previously selected as the network provider for the 27-site DC fast charging network. CFCI is working in partnership with EVgo to serve as the installer and network provider. CFCI has installed over 8,000 EVSE since 1999 and is one of the most experienced installers of EVSE in the U.S. These sites will be in addition to EVgo's CPUC settlement of installing 200 DC fast chargers in California and will be integrated into the EVgo network. CFCI and EVgo will operate the network for five years beyond the date of installation and will provide pay per use and subscription payment models to users. Two installations were completed in 2016 in the Cities of Calabasas and Palm Desert, with an additional five DC fast charging stations to be completed by April 2017 and an additional 20 DC fast charging stations to be completed by December 2017. CEC has awarded two revenue grants ARV-12-053 and ARV-13-026 of \$720,000 and \$500,000 respectively, with an additional \$883,800 in required cost sharing being provided by the project partners. DC fast chargers will be installed along major freeway corridors throughout the four-county SCAQMD jurisdiction to extend electric driving range throughout the region including to the Coachella Valley, San Diego, and Central Coast regions.

16200: Cost-Share Regional Universities for U.S. DOE EcoCAR 3 Competition

Contractor: California State University Los Angeles	SCAQMD Cost-Share	\$ 100,000
	Cosponsors	
	Competition Sponsors: DOE, GM, NSF, EPRI. Team Sponsors: CSULA, Xerox, Enerdel, Modern Kit Car	700,000
Term: 04/14/16 – 04/15/20	Total Cost:	\$ 800,000

EcoCAR 3 is an advanced plug-in hybrid passenger vehicle design-and-build competition sponsored by U.S. DOE and General Motors and managed by Argonne National Laboratory. California State University Los Angeles (CSULA) is the only competitor in California of 16 North American universities chosen to redesign a stock 2016 gasoline Chevrolet Camaro into a hybrid vehicle that will reduce the environmental impact of vehicles, minimize fuel consumption, retain performance, safety and consumer appeal, and provide research and innovation. For EcoCAR 3, the CSULA team has selected a police theme with pursuit capability. Switching to alternative fuels, enabling electric air conditioning, powering energy intensive loads from the battery pack and EV patrol modes will allow CSULA's vehicle to provide appreciable fuel economy along with substantial pollution and GHG reductions. Competition and Team Sponsors also contributed in-kind resources.

16227: Lease One 2016 Chevrolet Volt Extended-Range Electric Vehicle for Three Years

Contractor: Selman Chevrolet Company	SCAQMD Cost-Share	\$ 15,677
Term: 02/01/16 – 01/13/19	Total Cost:	\$ 15,677

As noted, the SCAQMD operates a number of AFVs in its Fleet Demonstration Program to support the use of zero emission vehicles and bring awareness to the public of their viability. In 2016 this lease for one 2016 Chevrolet Volt extended-range electric vehicle was executed, adding it to the Fleet Demonstration Program. The improved 2016 Volt offers many new features and up to 53 pure electric miles and up to 420 miles with a full charge and a full tank of gas and qualifies for incentives including green carpool stickers.

16081: Provide EV Hardware and Control System at SCAQMD Headquarters including Installation Support, Warranty and Networking

Contractor: Broadband TelCom Power, Inc.	SCAQMD Cost-Share	\$ 367,425
Term: 04/27/16 – 06/26/22	Total Cost:	\$ 367,425

A contract with Broadband TelCom Power, Inc. (BTC) was selected through an RFP process as the hardware provider for Level 2 charging stations to be installed at SCAQMD headquarters. BTC will provide up to 90 Level 2 charging ports in various areas of the parking lot, including the upper deck, solar carport, CC8, and front lobby. This contract was later modified to include additional funds for installation of Greenlots networking software and of a network of wifi gateways to enable EV charging stations to communicate with the Greenlots network. The Greenlots Sky networking software is able to handle EV charging sessions, provide user notifications on charging status and real-time availability, and data collection for analysis and sharing with the building’s energy management system to ramp down or turn off charging activity in response to overall building demand to minimize demand charges during peak hours in the summer months. The Sky platform is also capable of customizing charging rates per kWh, per hour, flat rate, time of day, duration of charging session, or other criteria and can provide customized messaging screens to inform EV drivers of fees to be charged and limitations on dwell time at charging stations.

17065: EV Infrastructure Installer

Contractor: Clean Fuel Connection, Inc.	SCAQMD Cost-Share	\$ 805,219
Term: 12/02/16 – 12/31/21	Total Cost:	\$ 805,219

SCAQMD had selected a contractor to install EV charging stations at SCAQMD headquarters in May 2016 but this contractor withdrew their bid. As a result, another installation contractor, Clean Fuel Connection, Inc. (CFCI) was selected to perform the installation work. Installation work commenced in October 2016 with the first phase of installation completed in January 2017. As part of this installation, there will be up to 90 new Level 2 charging ports (including up to six ADA accessible charging ports) completed in spring 2017. This project will include the replacement of existing Level 2 charging stations and upgrading of electrical infrastructure including transformers and electrical panels in multiple sections of the parking lot (upper deck, solar carport, CC8, front lobby).

Transfer: Zero Emission Drayage Truck Demonstration Project

Contractors: BYD Motors, Kenworth Truck Company, Peterbilt Motors and Volvo Technology of America	SCAQMD Cost-Share	\$ 6,001,531
	Cosponsors	
	California Air Resources Board	23,658,500
	Original Equipment Manufacturers	6,062,439
	Bay Area AQMD	3,000,000
	San Joaquin Valley APCD	1,000,000
	San Diego APCD	200,000
	San Diego Gas & Electric	200,000
Term: 03/04/16 – 03/04/16	Total Cost:	\$ 40,122,470

This project is to develop a portfolio of most commercially promising zero and near-zero emission drayage truck technologies for statewide demonstrations in and around the Ports of Los Angeles, Long Beach, Oakland, Stockton and San Diego, in collaboration with four other air districts: Bay Area AQMD, Sacramento Metropolitan AQMD, San Joaquin Valley APCD and San Diego APCD. For this project, SCAQMD has partnered with four major Original Equipment Manufacturers (OEMs) to build a total of 43 demonstration trucks, based on two BEV platforms by BYD and Peterbilt, that are well suited for local operations with approximately 100 miles in operating range, and two PHEV trucks, by Kenworth and Volvo respectively, to service a wider range of drayage operations with an operating range of 250 or higher miles. Participation of major OEMs with necessary technical and financial resources will not only ensure successful outcome of this demonstration, but will also lead to commercialization of these truck technologies, providing much needed air quality and public health benefits for the Basin, especially in the communities that are disproportionately exposed to harmful diesel emissions from cargo transport operations.

Direct Pay: Electric Vehicle Supply Equipment Installation

Contractor: Clean Fuel Connection, Inc.	SCAQMD Cost-Share	\$ 20,677
Term: 01/01/16 - 02/29/16	Total Cost:	\$ 20,677

This project provides funds for the demonstration of Level 2 electric vehicle charging stations from several manufacturers including ChargePoint, Clipper Creek, LiteOn, AeroVironment, and BTC Power, Inc. Clean Fuel Connection, Inc. purchased and installed Level 2 chargers at various locations. These chargers have been utilized extensively by SCAQMD Governing Board members, staff, and the general public.

Direct Pay: Short Circuit Study for Headquarters Electric Vehicle Infrastructure

Contractor: Southern California Edison	SCAQMD Cost-Share	\$ 400
Term: 01/01/16 – 01/01/16	Total Cost:	\$ 400

The City of Diamond Bar required a short circuit study as part of SCAQMD's upgrade of electric vehicle service equipment at SCAQMD's Headquarters. This was in conjunction with the work being

performed by Broadband TelCom Power, Inc. and Clean Fuel Connection, Inc.

Engine Systems

16205: Develop, Integrate and Demonstrate Ultra-Low Emission 12-Liter Natural Gas Engines for On-Road Heavy-Duty Vehicles

Contractor: Cummins Westport, Inc.	SCAQMD Cost-Share <i>(partially received as pass-through funds)</i>	\$ 2,750,000
	Cosponsors	
	California Energy Commission	2,000,000
	Cummins Westport, Inc. (in-kind)	1,000,000
	Clean Energy	500,000
Term: 06/03/16 – 06/30/18	Total Cost:	\$ 6,250,000

Heavy-duty on-road diesel vehicles are projected to be among the top sources of NO_x emissions in the South Coast Air Basin (SCAB) in 2023. Development of ultra-low emission engines that emit 90% lower NO_x than the 2010 0.2 g/bhp-hr NO_x standard would significantly reduce their emissions and assist the region in meeting federal ambient air quality standards in future years. The Cummins Westport ISL-G NZ 8.9-liter natural gas engines, developed with the funding from the SCAQMD, the California Energy Commission, and Southern California Gas Company, was certified by CARB to the Optional 0.02 g/bhp-hr NO_x standard and is now in production. However, the 8.9-liter engine is too small for heavy-heavy duty vehicles in Class 8. The objective of this project is to apply the ultra-low emission engine and after-treatment technologies developed for the 8.9-liter ISL-G Z engine to the 11.9-liter ISX12-G Cummins Westport engine. The project includes (1) engine and after-treatment system design, development, and emission testing (2) integration of the engine and after-treatment system into multiple vehicle chassis, and 3) on-road demonstrations including chassis dynamometer testing. Development targets are (1) power and torque suitable for heavy-heavy duty Class 80 vehicles, (2) commercially viable, (3) certification to the CARB Optional NO_x standard of 0.02 g/bhp-hr, and (ammonia emissions and fuel economy penalties as low as possible. Additionally, this contract will be modified in 2017 to add both the California Energy Commission's \$2,000,000 and Clean Energy's \$500,000 cost-share as pass-through funds.

Fueling Infrastructure and Deployment (NG/RNG)

16075: Purchase One Heavy-Duty CNG-Powered Truck

Contractor: City of Desert Hot Springs	SCAQMD Cost-Share	\$ 38,000
	Cosponsor	
	AB 2766 Discretionary Fund Program/MSRC	25,000
Term: 03/11/16 – 03/10/20	Total Cost:	\$ 63,000

Alternative fueled vehicles play an important role in Southern California's efforts to meet federally mandated fine particulate and ozone air quality standards. In July 2015 the Board approved co-funding of \$38,000 with the MSRC to purchase a heavy-duty CNG-powered stakebed truck for the City of Desert Hot Springs that was originally awarded in 2009. In 2016 the City purchased and immediately deployed a 12-foot stakebed truck built on a Ford F450 chassis. The base gasoline engine is the spark-ignited

6.8L Ford Triton V-10. The vehicle was converted to dedicated CNG fuel with a heavy-duty CNG system manufactured and CARB certified by IMPCO. The vehicle is fitted with 31 GGE of on-board CNG storage. The F450 replaced an older gasoline powered Ford F150 Pickup truck. The total cost of the vehicle was \$61,388.

16244: Renewable Natural Gas Production and Vehicle Demonstration Project

Contractor: CR&R, Inc.	SCAQMD Cost-Share	\$ 900,000
	Cosponsors	
	CR&R, Inc.	46,080,000
	California Energy Commission	4,520,000
	CalRecycle	3,000,000
	AB 2766 Discretionary Fund Program/MSRC	500,000
Term: 09/03/16 – 03/02/20	Total Cost:	\$ 55,000,000

Heavy-duty vehicles powered by conventional fossil fuels contribute significantly to local air pollution and contribute significantly to GHG emissions. The use of near-zero emission heavy-duty engine fueled with renewable natural gas can have a significant effect on addressing both of these air quality objectives. In October 2015 the Board approved \$900,000 to support the expansion (Phase 2) of CR&R's anaerobic digestion and biomethane production facility in Perris, CA. Anaerobic digestion uses microorganisms to convert organic matter into useable and renewable natural gas (RNG), and into soil amendments that enhance plant growth and soil cultivation. The organic matter or feedstock for this facility is municipal solid waste, such as food and green waste that is collected in residential and commercial trash collection. The RNG produced at this facility will fuel CR&R's fleet of CNG-powered heavy-duty refuse collection vehicles, and the soil amendment produced at this facility will be used to grow plants and animal feed that will make its way back into the food and green waste cycle. This project will also demonstrate near-zero emission heavy-duty refuse collection vehicles powered by the Cummins-Westport 8.9L and 12L engines certified to CARB's Optional Low NOx Standard. These vehicles will be fueled with RNG produced at this facility. Finally, the RNG produced at this facility that is not used by CR&R will be introduced into the gas pipeline grid in cooperation with the Southern California Gas Company. Each phase of this facility is expected to generate 890,000 DGE of RNG annually.

16333: Implement Alternative Fuel Station Expansion

Contractor: Ontario CNG Station, Inc.	SCAQMD Cost-Share	\$ 200,000
	Cosponsors	
	Ontario CNG Station, Inc.	448,535
	AB 2766 Discretionary Fund Program/MSRC	150,000
Term: 05/13/16 – 11/12/19	Total Cost:	\$ 798,535

Alternative fueled vehicles play an important role in Southern California's efforts to meet federally mandated fine particulate and ozone air quality standards. In March 2016 the Board approved \$200,000 to support the expansion of compressed natural gas (CNG) fueling at a public access, multi-fuel retail station positioned in a high vehicle volume area near the Interstate 10 freeway, the Ontario International Airport and Ontario Convention Center. OntarioCNG sells conventional gasoline and diesel fuels, biodiesel, and also hydrogen fuel. It has a car wash and a 24/7 manned convenience store with

restrooms. This project will increase CNG refueling capabilities and fuel delivery systems, with two high flow nozzles designed to reduce refueling time for heavy-duty Class 7-8 vehicles. The project will add one new 486 scfm CNG compressor, 36,000 scf of additional CNG fuel storage capacity, two new CNG dispensers and four fueling hoses, a second fueling island, and will introduce the marketing of RNG fuel. Overall, this project is expected to add greater visibility of alternative fuels to a conventional fuel consumer base as well as increase CNG fueling and the number of CNG fueled vehicles in this region.

17092: Construct RNG Production Facility and Demonstrate RNG with Next Generation Natural Gas Engine

Contractor: KORE Infrastructure, LLC	SCAQMD Cost-Share <i>(partially received as pass-through funds)</i>	\$ 2,500,000
	Cosponsors	
	KORE Infrastructure, LLC & Partners	23,000,000
Term: 03/11/16 – 03/10/20	Total Cost:	\$ 25,500,000

In order to increase supply of renewable natural gas (RNG), KORE Infrastructure is to construct a new full-scale modular biomethane production facility in Rialto, CA using a proprietary process developed and demonstrated over a six-year period at a local wastewater plant. The proposed facility will utilize a fully integrated system to process biosolids from wastewater treatment facilities into RNG that can be used locally as transportation fuel in the next generation natural gas engines that are certified to achieve 90 percent lower NOx emissions than the existing 2010 heavy-duty engine exhaust emissions standard. This project will utilize a thermochemical process to decompose the organic material into gases and a solid known as biochar. This thermochemical process is called pyrolysis and involves heating the almost dry organic materials to elevated temperatures in the absence of oxygen. The gases produced are primarily comprised of hydrogen, carbon monoxide, carbon dioxide, and methane. The components of this gas can then be reformed into other products including RNG. In September 2016 the Board approved \$1 million dollars from the Clean Fuels Fund and \$1.5 million from the BP ARCO Settlement Projects Fund (46). Kore’s patented process consists of five stages: (1) material handling, (2) drying, (3) pyrolysis, (4) methanation (pyrolysis gas conversion to RNG), and (5) compression. The facility is expected to process nearly 300 tons per day of biosolids and produce about 1,000 GGE of transportation fuel grade RNG. The RNG production and dispensing facility is anticipated to be fully operational in 2018. KORE will initially convert up to two diesel trucks from their fleet to operate on the RNG produced at the new facility and work with local fleets to provide RNG for fleet vehicles equipped with low-NOx technology engines.

Direct Pay: 2015-16 Enhanced Fleet Modernization Program (EFMP) Plus-Up

Contractor: various	SCAQMD Cost-Share	\$ 1,033,500
	Cosponsors	
	California Air Resources Board/Bureau of Automotive Repair	5,000,000
	MSRC/AB 2766 Discretionary Fund Program	1,550,250
	Special Revenue Fund/AB 923	516,750
Term: 01/08/16 – 01/08/16	Total Cost:	\$ 8,100,500

The Enhanced Fleet Modernization Program is a state-funded program which is branded as the “Replace Your Ride” program in the SCAQMD. Through this pilot program, low- and moderate-income participants are offered incentives to replace their existing vehicles with cleaner, more fuel-efficient vehicles, or alternatively, to obtain vouchers for alternative transportation such as transit passes and ridesharing. Additional incentives are available to participants who live in disadvantaged communities and obtain advanced technology replacement vehicles such hybrids, PHEVs, and ZEVs. The program has been well received in the SCAQMD. Local match funds were provided in FY 2015-16 by the Clean Fuels Fund, MSRC, and the Special Revenue Fund, which support SCAQMD’s high rate of program participation.

Direct Pay: Purchase of Electric Leaf Blowers and Trimmers for Lawn and Garden Demonstration Program

Contractor: Varies		\$ 4,195
Term: 03/31/16 – 03/31/16	Total Cost:	\$ 4,195

In 2014 SCAQMD launched a Commercial-Grade Electric Lawn and Garden Equipment Program to demonstrate commercial-grade electric lawn mowers and cordless electric hand-held lawn and garden equipment to promote and accelerate market penetration of such equipment in the South Coast Air Basin. The program was implemented with participating local gardening and landscape professionals as well as municipalities, universities and other eligible entities. The Program loans the equipment to participants on a rotating basis for 60-90 days and equipment contractors have been responsible for training users on safe and proper operation and maintenance of the equipment and providing necessary technical and logistical support. In 2016 additional equipment was purchased to continue the successful demonstration efforts.

Direct Pay: 2016-17 Enhanced Fleet Modernization Program (EFMP) Plus-Up

Contractor: various	SCAQMD Cost-Share	\$ 1,503,000
	Cosponsors	
	California Air Resources Board	13,700,000
	MSRC/AB 2766 Discretionary Fund Program	2,254,500
	Special Revenue Fund/AB 923	751,500
Term: 09/02/16 – 09/02/16	Total Cost:	\$18,209,000

Implementation of the Enhanced Fleet Modernization Program continues in FY 2016-17 with the support of local match funds from the Clean Fuels Fund, MSRC, and the Special Revenue Fund. The vast majority of funding has benefitted low-income participants who live in disadvantaged communities. Through this program, over 1,300 participants have scrapped their vehicles and replaced them with cleaner vehicles, primarily hybrids, PHEVs and BEVs.

Fuels/Emissions Studies

16198: Study of Opportunities and Benefits of Deploying Next Generation Heavy-Duty Natural Gas Vehicles Operating on Renewable Natural Gas

Contractor: Gladstein, Neandross & Associates, LLC	SCAQMD Cost-Share	\$ 50,000
--	-------------------	-----------

	Cosponsors	
	American Gas Association	50,000
	California Natural Gas Vehicle Partnership	50,000
	Clean Energy	50,000
	Southern California Gas Company	50,000
Term: 03/11/16 – 03/10/20	Total Cost:	\$ 250,000

The next generation of cleaner ultra-low-NOx on-road heavy-duty combustion engines that achieve a 90 percent reduction in NOx emissions compared to the current emissions standard are currently being developed. These “near-zero” emission engines will play a significant role for the region to attain federal ambient air quality standards. Given the focus on climate change, the natural gas industry has been expanding its efforts to provide biomethane or renewable natural gas (RNG) to the transportation fuels market. As RNG use continues to increase, there is interest in further understanding the opportunities to introduce RNG as a transportation fuel and how RNG can be introduced into the natural gas pipeline. In November 2015 the Board approved a cost share of \$50,000 to conduct a study on the opportunities and benefits of deploying next generation heavy-duty natural gas vehicles fueled by RNG. The resulting technical whitepaper, titled “Gamechanger – Next Generation Heavy-Duty Natural Gas Engines Fueled by Renewable Natural Gas”, considered criteria pollutant and greenhouse gas benefits of ultra-low-NOx natural gas engines, the opportunities and cost to deploy such engines, and an evaluation of the market successes of RNG, future opportunities and challenges of increasing the use of RNG as a transportation fuel, and expanding the commercial deployment of ultra-low NOx heavy-duty vehicles locally, and regionally.

16254: Evaluate Ozone and Secondary Aerosol Formation from Diesel Fuels

Contractor: University of California Berkeley	SCAQMD Cost-Share	\$ 106,361
Term: 10/25/16 – 08/31/17	Total Cost:	\$ 106,361

Diesel vehicle exhaust and unburned diesel fuel are major sources of intermediate volatile organic compounds (IVOCs) and may contribute to the formation of urban ozone and secondary organic aerosol (SOA), which is an important component of particulate matter 2.5 (PM2.5). The characterization of IVOC emissions is critical in assessing ozone and SOA precursor production rates. Traditionally, laboratory measurements of IVOCs have been prohibitively difficult. For this project, novel experimental measurements and emissions modeling of typical diesel blends under varying temperatures and wind speeds will be used to determine potential ozone and SOA yields in urban areas.

17060: Bailment Agreement for Equipment Use for In-Use Emissions Testing of Heavy-Duty Inspection and Maintenance Program

Contractor: University of California Riverside	SCAQMD Cost-Share	\$ 0
Term: 10/13/16 – 10/12/18	Total Cost:	\$ 0

The University of California, Riverside’s Bourn’s College of Engineering – Center for Environmental Research and Technology (UCR/CE-CERT) is currently initiating a program entitled “Heavy-Duty On-Road Vehicle Inspection and Maintenance (I/M) Program” that is being funded by the California Air Resources Board. This program is to provide important information that will be utilized in the enhancement of CARB’s Heavy-Duty I/M program. It is expected that any updates to CARB’s Heavy-Duty I/M program would be implemented throughout the state and would become a critical part of emission reduction strategies in future Air Quality Management Plans for the SCAQMD. An important element of this CARB study will be an extensive emissions evaluation of over 50 heavy-duty trucks before and after repairs. The CARB program covers the costs associated with the chassis dynamometer testing and repairs, but does not incorporate budget for the necessary emissions analyzers. This in-kind contribution from the SCAQMD would be a critical element in the success of this specific project. In exchange for the loan of the emissions analyzers for approximately a two-year period, UCR/CE-CERT will provide emissions analysis information that will be used to help the SCAQMD achieve its goals in improved air quality.

Technology Assessment/Transfer and Outreach

08210: Technical Assistance on Mobile Source Control Measures and Future Consultation on TAO Activities

Contractor: Sawyer Associates	SCAQMD Cost-Share	\$ 10,000
Term: 02/22/08 – 02/28/18	Total Cost:	\$ 10,000

The Office of Science and Technology Advancement (STA) augments in-house expertise with consultants who perform through level-of-effort technical assistance contracts. Under this contract executed in 2008, Dr. Robert F. Sawyer provides technical assistance to further develop and refine the mobile source control measures. In addition, he provides assistance in air toxics control measures, review of SCAQMD programs such as the Clean Fuels projects, input to greenhouse gas and energy diversity policies, and state regulatory activities, such as the ZEV and ZBus regulations. Dr. Sawyer is the former Chairman of the California Air Resources Board and has over 50 years of domestic and international experience specializing in automotive emissions, alternative fuels, air pollution and environmental issues. He has additional experience in air pollution regulatory policy advising. Dr. Sawyer is a Professor of the Graduate School and the Class of 1935 Professor of Energy Emeritus at the University of California at Berkeley and a Visiting Professor of Energy and Environment at University College London. Dr. Sawyer serves on the Clean Fuels Advisory Committee.

17037: Technical Assistance with Alternative Fuels, Electric Vehicles, Charging and Fueling Infrastructure and Renewable Energy

Contractor: Clean Fuel Connection, Inc.	SCAQMD Cost-Share	\$ 50,000
Term: 11/18/16 – 11/17/18	Total Cost:	\$ 50,000

SCAQMD relies on expert input, consultation and support to manage a number of programs

conducted under the Clean Fuels Program and incentive programs. Clean Fuel Connection, Inc. (CFCI), is providing technical assistance with alternative fuels, renewable energy and electric vehicles as well as outreach activities to promote, assess, expedite and deploy the development and demonstration of advanced, low and zero emissions mobile and stationary technologies. This contract is for technical and administrative support to enable the range of activities involved in implementing the Clean Fuels Program and associated complimentary programs as needed.

17097: Technical Assistance with Alternative Fuels and Fueling Infrastructure, Emissions Analysis and On-Road Sources

Contractor: Gladstein, Neandross & Associates LLC	SCAQMD Cost-Share	\$ 100,000
Term: 11/04/16 – 11/03/18	Total Cost:	\$ 100,000

This contract leverages staff resources with specialized outside expertise. Gladstein, Neandross & Associates LLC (GNA) has previously assisted SCAQMD with implementing a wide-array of incentive programs to deploy lower-emitting heavy-duty vehicles and advanced transportation technologies. Under this contract, GNA will provide technical expertise across a broad spectrum of emission reduction technologies, including alternative and renewable fuels and fueling infrastructure, emissions analysis and heavy-duty on-road sources on an-as-needed basis.

Direct Pay: Insurance for Alternative Fuel Vehicles in Technology Advancement Office's Fleet Demonstration Program

Contractor: Hartford/Alliant Insurance	SCAQMD Cost-Share	\$ 31,414
Term: 01/01/16 – 12/31/16	Total Cost:	\$ 31,414

In order to showcase and demonstrate advanced, low-emission technologies, the SCAQMD often leases and/or purchases clean alternative fuel vehicles to educate public and private organizations on the benefits of advanced technologies, as well as provide valuable in-use test data to the manufacturers. These vehicles are displayed at outreach events and conferences, used in Ride-and-Drive demonstrations, and are part of the SCAQMD carpool fleet. Private insurance is obtained for these advanced technology vehicles to ensure proper coverage.

Transfer: Participation in California Natural Gas Vehicle Partnership for Fiscal Year 2016-17 and 2017-18

Contractor: Transfer from Clean Fuels	SCAQMD Cost-Share	\$ 25,000
	Cosponsors	
	CNGVP Participating Members	130,000
Term: 07/08/16 – 07/08/16	Total Cost:	\$ 155,000

The California Natural Gas Vehicle Partnership (CNGVP) was formed to accelerate the development of advanced natural gas vehicle technologies to provide a benchmark for lowering emissions from petroleum-based engines and to provide a pathway to future fuel cell use in the next two decades. The SCAQMD spearheaded the formation of this strategic alliance, which comprises state and federal air quality, transportation and energy agencies, vehicle and engine manufacturers, fuel providers, and transit and refuse hauler organizations. Partnership Steering Committee members contribute monies to fund specific projects intended to achieve the goal of the Partnership. In July 2016 the SCAQMD approved \$25,000 for the SCAQMD's participation in the Steering Committee for the next two years.

Direct Pay: Participation for CY 2016 Membership in Transportation Research Board

Contractor: Transportation Research Board	SCAQMD Cost-Share	\$ 32,500
	Cosponsors	
	Core Program Participating Members	191,000
Term: 07/01/16 – 12/31/16	Total Cost	\$ 223,500

In 2016 the SCAQMD supported the Transportation Research Board (TRB) by participating as a member. The mission of the TRB is to promote innovation and progress in transportation through research. In an objective and interdisciplinary setting, TRB facilitates the sharing of information on transportation practice and policy by researchers and practitioners; stimulates research and offers research management services that promote technical excellence; provides expert advice on transportation policy and programs; and disseminates research results broadly and encourages their implementation. TRB's varied activities annually engage more than 7,000 engineers, scientists, and other transportation researchers and practitioners from the public and private sectors and academia, all of whom contribute their expertise in the public interest by participating on TRB committees, panels and task forces. TRB is one of six major divisions of the National Research Council (NRC) - a private, nonprofit institution that is jointly administered by the National Academy of Sciences, the National Academy of Engineering and the Institute of Medicine - and is the principal operating agency of the National Academies in providing services to the government, the public and the scientific and engineering communities. Sponsors and affiliates provide support for TRB core programs and activities. Sponsors are the major source of financial support for TRB's core technical activities. Federal, state, and local government agencies and professional societies and organizations that represent industry groups are eligible to be TRB sponsors. TRB's annual expenditures for program activities exceed \$90 million.

Direct Pay: Cosponsor 24 Conferences, Workshops & Events plus 4 Memberships

Contractor: Various	SCAQMD Cost-Share	\$ 282,658
	Cosponsors	
	Various	4,017,865
Term: 01/01/16 – 12/31/16	Total Cost	\$ 4,300,523

The SCAQMD regularly participates in and hosts or cosponsors conferences, workshops and events. These funds provide support for the 24 conferences, workshops and events sponsored throughout 2016 as follows: Calstart's Clean Low Carbon Fuels Summit in February; Linn-Benton Community College's Green Transportation Summit & Expo in February; UC Riverside's Solar Conference in February; UC Riverside's 2016 PEMS Conference in March; UCI's 2016 ICEPAG/MGS Conference in March; Coordinating Research Council's 2016 Real World Emissions Workshop in March; U.S. EPA's West Coast Collaborative Meeting in April; California Science Fair in May; GNA's 2016 ACT Expo in May; CleanTechOC's Advanced Transportation Symposium in June; GNA's 2016 Rethink Methane Symposium in June; 2016 Women in Green Forum in August; 2016 FuturePorts Annual Conference in June; SCCAA's LA Environmental Forum in August; JPL's 2016 Climate Day in September; Clean Fuels Advisory Group Retreats in January & September 2016; Adopt-A-Charger's 2016 National Drive Electric Week Event in September; Platia Productions' 2016 Santa Monica AltCar Expo & Conference in September; GNA's Ultra-Low NOx Heavy-Duty Engines Workshop in October; BRC's 2016 Southern California Energy Water + Green Living Summit in October; Energy Vision's Renewable Natural Gas for California Workshop in October; CalETC's 2016

Los Angeles Auto Show Events in November; CHBC's Hydrogen & Fuel Cells in the Ports Workshop in November; as well as GNA's upcoming 2017 Rethink Methane Symposium. Additionally, for 2016 four memberships were renewed for participation in the PEV Collaborative, the Fuel Cell & Hydrogen Energy Association, the California Hydrogen Business Council, and the Air & Waste Management Association.

PROGRESS AND RESULTS IN 2016

Key Projects Completed

A large number of emission sources contribute to the air quality problems in the South Coast Air Basin. Given the diversity of these sources, there is no single technology or “silver bullet” that can solve all of the region’s problems. Accordingly, the SCAQMD continues to support a wide range of advanced technologies, addressing not only the diversity of emissions sources, but also the time frame to commercialization of these technologies. Projects cofunded by the SCAQMD’s Clean Fuels Program include emission reduction demonstrations for both mobile and stationary sources, although legislative requirements limit the use of available funds primarily to on-road mobile sources.

Historically, mobile source projects have targeted low-emission technology developments in automobiles, transit buses, medium- and heavy-duty trucks and off-road applications. These vehicle-related efforts have focused on: 1) development, integration and demonstration of ultra-low emission natural gas engines for on-road heavy-duty engines; 2) Develop and Demonstrate Plug-In Hybrid Electric Drive System for Medium- and Heavy-Duty Vehicles; and 3) Operation & Maintenance of City of Burbank Hydrogen Fueling Station.

Table 6 (page 63) provides a list of 43 projects and contracts completed in 2016. Summaries of the completed technical projects are included in Appendix C. Selected projects which represent a range of key technologies from near-term to long-term are highlighted below.

Develop, Integrate and Demonstrate Ultra-Low Emission Natural Gas Engines for On-Road Heavy-Duty Engines

Heavy-duty on-road diesel vehicles are currently, and expected to remain, one of the largest contributors of NOx emissions, even as the legacy fleet of older vehicles are retired and replaced by vehicles meeting the 2010 emissions standards. Ultra-low NOx emission engines provide a path to significantly reduce NOx emissions from the heavy-duty vehicle source category and are the linchpin for achieving the federal ambient air quality standards in the future. SCAQMD staff has worked closely with the California Energy Commission, Southern California Gas Company, U.S. Department of Energy and others on developing a range of engine sizes (6-15 liter) that could be considered an ultra-low NOx emissions engine for heavy-duty vehicles, ranging from Class 4-8. Concurrently, CARB also adopted optional NOx emission standards, including 0.02 g/bhp-hr, to enable incentive funding for new vehicles equipped with certified ultra-low emission engines.

In late 2013, the Board awarded a contract to Cummins, Inc., to develop an ultra-low NOx emission 15-liter natural gas engine. The project included emission targets of 0.02 g/bhp-hr NOx, other 2010 criteria pollutant standards, and 10 ppm ammonia or as low as possible using EPA and CARB certification test procedures. In addition, other objectives affecting commercial viability of the engine included minimal energy efficiency loss compared to diesel and providing power, life cycle cost, performance, drive quality, and durability similar to diesel.

The project was completed in June 2016. The engine was derived from the Cummins 14.9-liter ISX15 diesel engine but had newly designed manifolds, heads, camshaft, piston, EGR, turbocharger and catalyst aftertreatment all specifically designed for optimal performance with natural gas. The final technology configuration consisted of:



Figure 36: ISX15-G Ultra Low NOx Test Engine

- Stoichiometric air-fuel ratio
- Port fuel injection
- Big intake - small exhaust valves
- Improved cooling of head and spark plugs
- Flow-optimized intake manifold
- Flow-optimized exhaust manifold
- High energy ignition system
- Cooled EGR
- Waste-gate turbocharger
- Close-coupled and main underbody three-way catalyst system

An engine containing the final internal and external engine hardware, optimized control software, and after treatment system was tested according to the cold/hot Heavy Duty Engine Federal Test Procedure (HD-FTP) and was operated without failure for more than 500

hours under a wide range of speed and load conditions. The engine and aftertreatment system achieved the near-zero emission targets, fuel consumption lower than current natural gas engines; and incorporated design changes to improve engine robustness and driving performance, particularly during transient operation, and reduce maintenance cost. Ammonia emissions, although not achieving the target, were substantially lower than current production natural gas engines. Further optimization of software controls and the aftertreatment system is expected to reduce ammonia below 20 ppm.

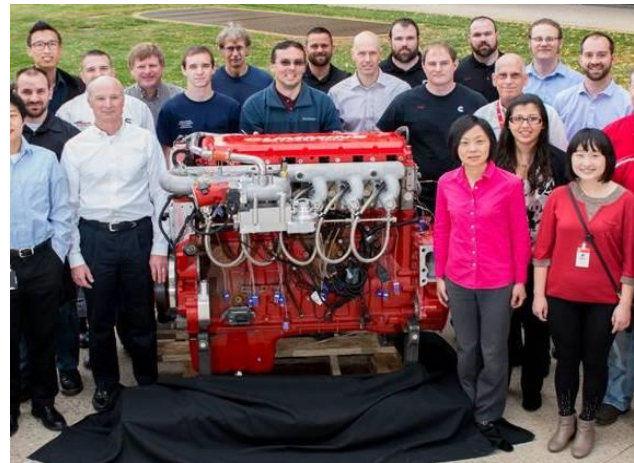

Figure 35: ISX15-G Ultra Low NOx Prototype Engine

Table 5: Emissions Testing Results

Parameter	Target	ISX15-G
NOx	0.02	0.003
PM	0.01	0.004
NMHC	0.14	0.010
CO	15.5	1.85
Ammonia	10 ppm	58 ppm
BTE loss*	minimal	1%

*Brake Thermal Efficiency Loss vs Diesel

This project demonstrated that a well-designed natural gas engine can achieve both ultra-low NOx emissions as well as thermal efficiency and performance equivalent to diesel engines. The project also provided a design pathway for developing other ultra-low NOx natural gas engines with performance

similar to a diesel engine which is described in the final report and two technical papers. Unfortunately, market demand for a 15-liter natural gas engine is currently insufficient to justify launching this new engine at this time. The technology is scalable over an 8- to 15-liter size range, and Cummins intends to incorporate this technology in the next natural gas engine which is expected to be released in the 2019-2020 timeframe.

In 2015, the 8.9L Cummins Westport was also certified to a 0.02 g/bhp-hr NO_x standard and has since been fully commercialized, with ongoing efforts to develop, certify and commercialize the 6.7L and 11.9L natural gas engines. Furthermore, CARB and SCAQMD are collectively working on parallel efforts to develop liquid-fueled, large displacement engines suitable for long-haul operations that can also meet the 0.02 g/bhp-hr for NO_x.

Based on the success of the engine development efforts, the SCAQMD, along with CARB and numerous other states, petitioned the U.S. EPA to establish a national near-zero NO_x heavy-duty engine standard. In November 2016, CARB initiated the California heavy-duty emission standard rule development effort, and subsequently, in December 2016, U.S. EPA informed the petitioners of their goal to evaluate and consider the national heavy-duty engine standard. If the federal or state standard is revised, a market for the 15-liter engine developed under this contract is expected to develop.

Develop and Demonstrate Plug-In Hybrid Electric Drive System for Medium- and Heavy-Duty Vehicles

The Odyne Systems' hybrids are in Class 6 to Class 8 trucks. These are parallel plug-in hybrid vehicles and can improve fuel economy by up to 50% and reduce emissions. The Odyne hybrids come equipped with 6 or 12 kW of export power. The hybrid system adapts to the traction and the aerial hydraulics of the vehicle. The Odyne equipped trucks were designed, developed, validated and produced within this SCAQMD program and a DOE ARRA funded program. Odyne now has the capability to produce more of these vehicles. Cost analysis has been done to understand future cost reduction.

The Odyne hybrid system is a simple, parallel hybrid system that allows the torque of the electric motor to augment the torque output of the diesel engine, thus saving fuel. The motor speed is synchronized with the engine speed through the power take-off (PTO) unit. The traction motor drives the PTO, adding torque to the rear axle, or converts torque from the PTO into power to charge the hybrid batteries. Six patents have been granted, and other patents are pending.

The motor can also drive the hydraulic pump that controls the aerial device. A clutch in the PTO allows the motor to drive the hydraulic pump for the aerial device. If the clutch is closed, the diesel engine torque drives the pump and concurrently charges the hybrid batteries through the traction motor.

The advantages of the electrically driven hydraulic pump are reduction in sound level at the job site, improved fuel consumption, and reduced emissions. The diesel engine need not idle during the hydraulic pump control. The pump is activated only when the operator provides the control to move the hydraulics. This feature saves energy when the aerial device is being used.

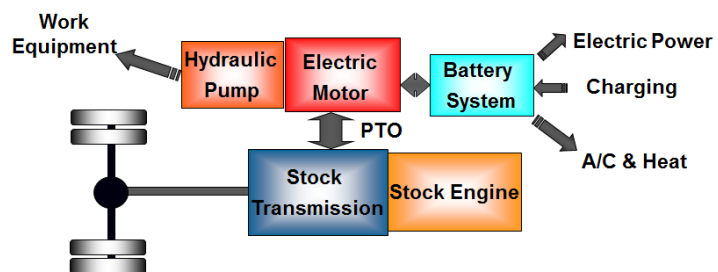

Figure 37: Odyne Plug In Hybrid System

Operation & Maintenance of City of Burbank Hydrogen Fueling Station

Steam methane reformation (SMR) is currently used to produce the majority of hydrogen in California, typically from a large central plant that primarily produces hydrogen for petroleum refining and other industrial uses, but a portion of which can be further purified and transported to light-duty hydrogen fueling stations. Onsite reformers can eliminate hydrogen transportation (reducing emissions), but smaller onsite reformers are not as cost-effective. This onsite reformer station was built in 2009 by British Petroleum, with funding and support provided by U.S. DOE and General Motors, following the completion of the original electrolysis-based hydrogen fueling station, which was part of the Five Cities Hydrogen Demonstration Program.



Figure 38: Odyne Utility Bucket Truck

In 2010, in order to support the continued and growing need for hydrogen fueling in the region, U. S. DOE, CARB, CEC, and SCAQMD contracted with Hydrogen Frontier, Inc. to repair equipment, restart, operate and maintain this hydrogen fueling station, train staff in use of equipment and procedures, and provide detailed vehicle fueling reports to NREL. SCAQMD added funds to continue operation and maintenance and pay for the increase in utility services (electricity and natural gas) for the onsite reformer and station.

Flexible fueling protocols satisfied a variety of automaker needs during development and demonstration of new fuel cell vehicles, but now, the need for longer range and fast refueling under a wide range of ambient conditions has resulted in a new standardized protocol. As with other non-retail hydrogen stations operating during this time period, access was controlled by PIN codes issued to drivers that completed hydrogen safety training. The SMR has nearly 19,000 runtime hours and demonstrates that operation and maintenance of on-site reformation can be a reasonable-cost option. New stations are increasing monitoring of hydrogen quality to protect the operation of fuel cell vehicles.

With the continued support of the City of Burbank, this location near the intersection of two major freeways remains desirable and has proven a viable asset to the infrastructure network. However, most new light-duty hydrogen stations are being co-located at gasoline stations in a retail environment. Continued operation and maintenance of hydrogen fueling at this site helped bridge the gap in preparation for additional upgrades commencing in 2017 to provide retail sale of hydrogen for light-duty vehicles using funding from a grant award under the CEC AB 118 Program.



Figure 39: Burbank Hydrogen Station

Table 6: Projects Completed between January 1 & December 31, 2016

Contract	Contractor	Project Title	Date
Hydrogen and Mobile Fuel Cell Technologies and Infrastructure			
11150	Hydrogen Frontier Inc.	Operation and Maintenance of City of Burbank Hydrogen Fueling Station	Jan-2016
16151†	Toyota Motor Sales USA	No Cost Loan of 2015 Toyota Mirai Fuel Cell Vehicle	Jan-2016
17030	Bevilacqua-Knight, Inc.	Participate in California Fuel Cell Partnership for Calendar Year 2016 and Provide Support for Regional Coordinator	Dec-2016
Electric/Hybrid Technologies and Infrastructure			
10659	Electric Power Research Institute	Data Collection to Further Evaluate Performance and Operational Benefits to Optimize Fleet of Medium-Duty Plug-In Hybrid Vehicles	Sep-2016
11606	Odyne Systems, LLC	Develop and Demonstrate Plug-In Hybrid Electric Drive System for Medium- and Heavy-Duty Vehicles	Nov-2016
11615	Parker Hannifin	Develop and Demonstrate Heavy-Duty Hydraulic Hybrid Vehicles	Aug-2016
13404†	Penske Honda of Ontario	Lease Two Honda Fit Electric Vehicles for Three Years	May 2016
13410†	Selman Chevrolet Company	Lease Three 2013 Chevrolet Volt Extended-Range Electric Vehicles for Three Years Then Purchase Vehicles	Apr-2016
13429†	Longo Toyota	Lease One Toyota RAV4 Electric Vehicle for Three Years Then Purchase Vehicle	Apr-2016
14202	Adopt-A-Charger	SoCalEV Infrastructure MOA to Install & Upgrade EV Charging Infrastructure	Apr-2016
14204	Associated of Los Angeles	SoCalEV Infrastructure MOA to Install & Upgrade EV Charging Infrastructure	Apr-2016
14336	Los Angeles Department of Water & Power	Install and Upgrade EV Charging Infrastructure (Administer SoCalEV Infrastructure Project)	Apr-2016
15021	Transportation Power, Inc. (TransPower)	Upgrade and Demonstrate Two Electric Yard Tractors	Dec-2016
17058†	Adopt-A-Charger	Cosponsor the Los Angeles National Drive Electric Week 2016	Sep-2016
Engine Systems			
14364	Cummins, Inc.	Develop, Integrate and Demonstrate Ultra-Low Emission Natural Gas Engines for On-Road Heavy-Duty Vehicles	Aug-2016

Table 6: Projects Completed between January 1 & December 31, 2016

Contract	Contractor	Project Title	Date
Fueling Infrastructure and Deployment (NG/RNG)			
05250	Downs Commercial Fueling, Inc.	Purchase & Install New L/CNG Fueling System at Commercial Fueling Station in Temecula	Apr-2016
06042	UCLA Fleet & Transit Services	Upgrade Existing CNG Public Access Station with Dispenser and Card Reader	Dec-2016
06084	Clean Energy	Upgrade Existing LNG Facility to L/CNG at Riverside County Waste Management Department's Aqua Mansa Facility	Feb-2016
06091	City of Whittier	Purchase and Install New Public Access CNG Fueling Station at City Yard	Dec-2016
07153	Foothill Transit	Purchase and Install New Public Access CNG Fueling Station in Irwindale	Jun-2016
07320	Orange County Transportation Authority	Install New CNG Refueling Station in the City of Santa Ana	Mar-2016
08043	University of California Los Angeles	Public Access CNG Fueling Station Upgrade for UCLA Transportation	Dec-2016
08044	Beaumont Unified School District	Install Limited Access CNG Refueling Station	Dec-2016
09218	Rim of the World Unified School District	Install Mountain Safety Equipment on CNG School Buses	Dec-2016
10067	Rim of the World Unified School District	Install Mountain Safety Equipment on CNG School Buses	Dec-2016
11548†	Clean Energy (novated from Mansfield Gas Equipment Systems)	Buydown Incentive Program for CNG Home Refueling Appliance "Phill"	Jan-2016
13401	Nite-Hawk Sweepers LLC	Demonstrate Natural Gas-Powered Parking Lot Sweepers	May-2016
Fuels/Emissions Studies			
13402	University of California Davis	Cost-Share Next Sustainable Transportation Energy Pathways (STEPS) Program	Jul-2016
Stationary Clean Fuel Technologies			
10723	Eastern Municipal Water District	Retrofit Digester as Engine with NOxTech Aftertreatment Emission Control Technology	Mar-2016
Health Impacts Studies			
12208	University of California Riverside/CE-CERT	Determine the Physical and Chemical Composition and Associated Health Effects of Tailpipe PM Emissions	Jan-2016
12865	University of California Los Angeles	Develop Quantitative Cellular Assays to Understand the Chemical Basis of Air Pollutant Toxicity	Jul-2016
14172	University of California Irvine	Study of Oxidative Stress in Relation to Particulate Air Pollution Exposures in Elderly	Aug-2016

Table 6: Projects Completed between January 1 & December 31, 2016

Contract	Contractor	Project Title	Date
Technology Assessment/Transfer and Outreach			
00069†	Walsh Consulting	Technical Assistance Relating to the Use of Alternative Fuels in Mobile Sources	Feb-2016
07062†	The Tioga Group, Inc.	Technical Assistance Related to Air Quality Impacts of Regional Goods	Nov-2016
12380†	The Tioga Group, Inc.	Technical Assistance Related to Emissions, Advanced Technologies and Goods Movement	Apr-2016
13198†	Gladstein, Neandross & Associates LLC	Technical Assistance with Alternative fuels, Emissions Analysis and On-Road Sources	Dec-2016
15344†	Clean Fuel Connection, Inc.	Technical Assistance with Alternative Fuels, Electric Vehicles, Charging and Fueling Infrastructure and Renewable Energy	Sep-2016
15415†	Gladstein, Neandross & Associates LLC	Technical Assistance with Alternative Fuels and Fueling Infrastructure, Emissions Analysis and On-Road Sources	Nov-2016
16055†	University of California Irvine	Cosponsor Solar Decathlon to Develop and Demonstrate Solar-Powered House at 2016	Feb-2016
16263†	Gladstein, Neandross & Associates LLC	Cosponsor ACT Expo 2016	Sep-2016
16388†	CleanTech OC	Cosponsor the 2016 Advanced Transportation Symposium & Expo	Aug-2016
17062†	Burke Rix Communications	Cosponsor the Southern California Energy Water & Green Living 2016 Summit	Dec-2016
17088†	Energy Vision	Cosponsor the Power of Waste: Renewable Natural Gas (RNG) for California Workshop	Dec-2016

†Two-page summary reports (as provided in Appendix C) are not required for level-of-effort technical assistance contracts, leases or cosponsorships; or it was unavailable at time of printing this report.

[This Page Intentionally Left Blank]

CLEAN FUELS PROGRAM

2017 Plan Update

The Clean Fuels Program (Program) was first created in 1988, along with the SCAQMD's Technology Advancement Office (TAO). Funding for the Program is received through a \$1 motor vehicle registration fee. The Clean Fuels Program continually seeks to support the development and deployment of zero and near-zero emission technologies over a broad array of applications and spanning near- and long-term implementation. Planning has been and remains an ongoing activity for the Program, which must remain flexible to address evolving technologies as well as the latest progress in the state-of-technologies, new research areas and data.

Every year the SCAQMD re-evaluates the Clean Fuels Program based on the region's ongoing need for emissions reductions and develops a Plan Update for the upcoming calendar year (CY) targeting near-term projects to help achieve those reductions. This document is for the upcoming calendar year 2017.

Overall Strategy

The overall strategy of the SCAQMD's Clean Fuels Program is based primarily on technology needs identified through the AQMP process and the SCAQMD Governing Board's directives to protect the health of residents in Southern California, which encompasses approximately 17 million people (nearly half the population of California). The AQMP is the long-term "blueprint" that defines:

- basin-wide emission reductions needed to achieve federal ambient air quality standards;
- regulatory measures to achieve those reductions;
- timeframes to implement these proposed measures; and
- technologies required to meet these future proposed regulations.

The emission control needs and measures identified in the Draft 2016 AQMP projects that an approximate 43 percent reduction in NO_x is required by 2023 and a 55 percent reduction by 2031, the majority of which must come from mobile sources. Notably, the SCAQMD is currently only one of two regions in the nation recognized as an extreme ozone nonattainment area (the other is San Joaquin Valley). Ground level ozone (a key component of smog) is created by a chemical reaction between NO_x and VOCs emissions. This is especially noteworthy because in the South Coast Air Basin the largest contributor to ozone is NO_x emissions, and mobile sources (on- and off-road as well as aircraft and ships) contribute to approximately 88 percent of the NO_x emissions in this region. Furthermore, NO_x and VOC emissions also lead to the formation of PM_{2.5}, particulate matter measuring 2.5 microns or less in size, expressed as micrograms per cubic meter ($\mu\text{g}/\text{m}^3$).

The Draft 2016 AQMP includes integrated strategies and measures to demonstrate attainment of the following National Ambient Air Quality Standards (NAAQS):

- 8-hour Ozone (75 parts per billion or ppb) by 2031
- Annual PM_{2.5} ($12 \mu\text{g}/\text{m}^3$) by 2025
- 24-hour PM_{2.5} ($35 \mu\text{g}/\text{m}^3$) by 2019
- 8-hour Ozone (80 ppb) by 2023 (updated from the 2012 AQMP)
- 1-hour Ozone (120 ppb) by 2022 (updated from the 2012 AQMP)

The Draft 2016 AQMP also takes an initial look at the emission reductions needed to meet the new federal 8-hour ozone air quality standard of 70 ppb and projects that an additional 25 tpd in NOx reductions between 2031 and 2037 will be needed for attainment by 2037.

The daunting challenge to reduce NOx and PM2.5 to meet increasingly stringent standards require the Clean Fuels Program to encourage and accelerate advancement of clean fuel and transportation technologies, leading the way to commercialization of progressively lower-emitting fuels and vehicles. The NOx and VOC emission sources of greatest concern to this region are heavy-duty on-road and off-road vehicles. To underscore this concern, the 2015 Vehicle Technologies Market Report⁴, summarizing national data, released in spring 2016 by the Oak Ridge National Laboratory for the Department of Energy, and corroborated by EMFAC 2014 projections, notes that Class 8 trucks comprise 41% of the medium- and heavy-duty truck fleet but consume 78% of the fuel use in this sector. This is especially significant since the report also notes that Class 8⁵ truck sales have increased 45% from 2011 to 2015; and Class 4-7 trucks, 49%. Given the relationship between NOx, ozone and PM2.5, the 2017 Plan Update must continue to emphasize emission reductions in all these areas.

Since development of the 2012 AQMP, it became clear that the effect of moving containers through the Ports of Los Angeles and Long Beach and the subsequent movement of goods throughout the region not only have a dramatic impact on air quality but also the quality of life in the communities along the major goods movement corridors. The findings from the MATES IV⁶, which included local scale studies near large sources such as ports and freeways, reinforce the importance of these impacts and the need for transformative transportation technologies, especially near the ports and goods movement corridor. In recognition of these impacts, the SCAQMD added as a key element to its strategy a concerted effort to develop and demonstrate zero and near-zero emissions' goods movement technologies, such as electric trucks, plug-in hybrid trucks with all-electric range, zero emission container transport technologies, trucks operating from wayside power including catenary technology and heavy-duty technologies.

For over 28 years, a key strategy of the Clean Fuels Program has been its public-private partnership with private industry, technology developers, academic institutions, research institutions and government agencies. This public-private partnership has allowed the Program to leverage its funding with \$3-\$4 of spending on R&D projects to every \$1 of SCAQMD funds. While the SCAQMD thus aggressively seeks leverage funds to accomplish more with every dollar, it also strives to act as a leader in technology development and commercialization to accelerate the reduction of criteria pollutants.

As the state and federal governments have been turning much of their attention to climate change (CO2 reductions), the SCAQMD remains committed to developing, demonstrating and commercializing zero and near-zero emission technologies. Fortunately the majority of technologies that address our need for NOx reductions also enable greenhouse gas (GHG) reductions. Because of these "co-benefits," we have successfully pursued partnering with the state and federally-funded projects that promise emission reductions.

Program and Funding Scope

This 2017 Plan Update includes projects to develop, demonstrate and commercialize a variety of technologies, from near-term to long-term, that are intended to provide solutions to the emission control

⁴ http://cta.ornl.gov/vtmarketreport/pdf/2015_vtmarketreport_full_doc.pdf

⁵ 33,001 pounds and greater (Class 4-7 trucks, 14,001-33,000 pounds)

⁶ <http://www.aqmd.gov/home/library/air-quality-data-studies/health-studies/mates-iv>

measures identified in the Draft 2016 AQMP to address the increasing challenges this region is facing to meet air quality standards, including:

- 1) implementation of new and changing federal requirements, such as the federal 8-hour ozone standard of 70 ppb promulgated by U.S. EPA in late 2015;
- 2) implementation of new technology measures by including accelerated development of technologies getting ready for commercialization and deploying ready technologies; and
- 3) continued development of cost-effective approaches.

The overall scope of projects in the 2017 Plan Update also needs to remain sufficiently flexible to address new challenges and measures that are identified in the Draft 2016 AQMP, consider dynamically evolving technologies, and take into account new research and data. The latter, for example, includes the findings from the MATES IV study, which was undertaken to update the emissions inventory of toxic air contaminants, measure the concentration of ultrafine particles and black carbon (an indicator of diesel particulate emissions), and conduct a regional modeling effort to characterize risk to health across the Basin.

The Clean Air Act, in addition to providing for specific control measures based on known technologies and control methods, has provisions for more general measures based on future, yet-to-be-developed technologies. These “black box” measures are identified under Section 182(e)(5) of the Clean Air Act for regions that are extreme non-attainment areas, such as the South Coast Basin. In the past, some of the technologies that have been developed and demonstrated in the Clean Fuels Program may have served as guidance for the “black box.” On a positive note, the Draft 2016 AQMP calls for elimination on the reliance of these “black box” (future technologies) to the maximum extent possible. In fact, the Draft 2016 AQMP for the first time envisions Southern California achieving attainment without a reliance on “black box” technology. This is due in large part to the progress in the development and commercialization of zero and near-zero technologies, albeit with pathways that still require more specificity and in part because of the emission reduction co-benefits from carbon dioxide (CO₂) reductions expected from pursuit of climate change goals. There are significant challenges to getting there, however, including EPA moving forward with changing the heavy-duty engine exhaust NO_x standard from 0.2 grams per break horsepower-hour (g/bhp-hr) to 0.02 g/bhp-hr as well as identifying financial incentives to offset the cost of cleaner technologies.

Within the core technology areas defined later in this section, project objectives range from near-term to long-term. However, the SCAQMD Clean Fuels Program concentrates on supporting development, demonstration and technology commercialization and deployment efforts rather than fundamental research. The nature and typical time-to-product for the Program’s projects is described below, from near-term to longer-term.

Deployment or technology commercialization efforts focus on increasing the utilization of clean technologies in conventional applications, promising immediate and growing emissions reduction benefits. However, it is often difficult to transition users to a non-traditional technology or fuel, even if such a technology or fuel offers significant societal benefits. As a result, in addition to government’s role to reduce risk by funding technology development and testing, one of government’s roles is to support and offset any incremental cost through incentives to help accelerate the transition and use of the cleaner technology. The increased use and proliferation of these cleaner technologies often depends on this initial support and funding as well as efforts intended to increase confidence of stakeholders that these technologies are real, cost-effective in the long term and will remain applicable.

Technologies ready to begin field *demonstration* in 2017, are expected to result in a commercial product in the 2018-2019 timeframe, and technologies being field demonstrated generally are in the process of being certified. The field demonstrations provide a controlled environment for

manufacturers to gain real-world experience and address any end-user issues that may arise prior to the commercial introduction of the technology. Field demonstrations provide real-world evidence of a technology's performance to help allay any concerns by potential early adopters.

Finally, successful technology *development* projects are expected to begin during 2017 with durations of at least two years. Additionally, field demonstrations to gain longer-term verification of performance may also be needed prior to commercialization. Certification and ultimate commercialization would be expected to follow. Thus, development projects identified in this plan may result in technologies ready for commercial introduction as soon as 2020-2021. Projects are also proposed that may involve the development of emerging technologies that are considered longer term and, perhaps higher risk, but with significant emission reduction potential. Commercial introduction of such long-term technologies would not be expected until 2021 or later.

Core Technologies

The following technologies have been identified as having the largest potential and best prospects to enable the emission reductions need to achieve NAAQS and thus form the core of the Program.

Not all project categories will be funded due to funding limitations, and focus will remain on control measures identified in the 2016, with consideration for availability of suitable projects. The technical areas identified below are clearly appropriate within the context of the current air quality challenges and opportunities for technology advancement. Within these areas there is significant opportunity for SCAQMD to leverage its funds with other funding agencies to expedite the implementation of cleaner alternative technologies in the Basin. A concerted effort is continually made to form private partnerships to leverage Clean Fuels funds. For example, in January 2016, the SCAQMD was awarded \$23.5 million from CARB's Low Carbon Transportation Greenhouse Gas Emission Reduction Fund for heavy-duty truck projects. Finally, several of the core technologies discussed below are synergistic. For example, a heavy-duty vehicle such as a transit bus or drayage truck, may utilize an electric drive train with a fuel cell operating on hydrogen fuel or an internal combustion engine operating on natural gas or another alternative fuel as a range extender.

These priorities may shift during the year in keeping with the diverse and flexible "technology portfolio" approach. Changes in priority may occur to leverage opportunities such as cost-sharing by the state government, the federal government, or other entities. Priorities may also shift to address specific technology issues which affect residents within the SCAQMD's jurisdiction.

The following nine core technology areas are listed by current SCAQMD priorities based on the goals for 2017.

Electric/Hybrid Technologies & Infrastructure

Growing awareness of the need for better air quality is leading to stricter emission targets for vehicles in the near future. If the region expects to meet the federal standards for PM2.5 and ozone, a primary focus must be on zero and near-zero emission technologies. A leading strategy to achieve these goals is the electrification of transportation technologies on a wide and large scale. With that in mind, the SCAQMD supports projects to address the main concerns regarding cost, battery lifetime, travel range, charging station infrastructure and original equipment manufacturer (OEM) commitment. Integrated transportation systems can encourage further reduction of emissions by matching the features of electric vehicles (zero emissions, zero start-up emissions, modest all electric range) to typical consumer demands for mobility by linking them to transit. Additionally, the impact of fast charging on battery life and infrastructure costs needs to be better understood. This is especially important today when every month roughly 10,000 new plug-in vehicles are sold or leased in the U.S., and this number may

increase significantly if the Chevy Bolt and Tesla Model 3 with anticipated 200+ mile ranges become widely available.

The development and deployment of zero emission goods movement systems remains one of the top priorities for the SCAQMD to support a balanced and sustainable growth in the port complex. The SCAQMD continues to work with our regional partners, in particular the Ports of Los Angeles and Long Beach, the Southern California Association of Governments (SCAG) and Los Angeles County Metropolitan Transportation Association (LACMTA) to identify technologies that could be beneficial to and garner support from all stakeholders. Specific technologies include zero emission trucks (using batteries and/or fuel cells), near-zero emission trucks with all-electric range using wayside power (catenary or roadbed electrification) or with plug-in hybrid powertrains, locomotives with near-zero emissions (e.g., 90% below Tier 4), electric locomotives using battery tender cars and catenary, and linear synchronous motors for locomotives and trucks. Additionally, just this past July, the California Sustainable Freight Action Plan was released, to transition the state's freight system to an environmentally cleaner, more efficient and more economical one than it is today, including a call for a zero and near-zero emissions vehicle pilot project in Southern California. The Port of Los Angeles's Sustainable City Plan corroborates this effort, setting a goal of 15 percent of zero emission goods movement trips by 2025 and 35 percent by 2035, along with initiative to develop a one megawatt grid capability to generate 100 percent renewable energy for emergency use.

There are now over 19 light-duty plug-in hybrid (PHEVs) and pure battery electric vehicles (BEVs) commercially available. All of these vehicles offer the benefits of higher fuel economy and range, as well as lower emissions. Continued advancements in the light-duty arena may have applications for medium- and heavy-duty vehicles.

Opportunities to develop and demonstrate technologies that could enable expedited widespread use of electric and hybrid-electric vehicles in the Basin include the following:

- demonstration of electric and hybrid technologies for cargo container transport operations, e.g., heavy-duty battery electric or plug-in electric drayage trucks with all electric range;
- demonstration of medium-duty electric and hybrid electric vehicles in package delivery operations, e.g., electric walk-in vans with fuel cell or CNG range extender ;
- development and demonstration of CNG hybrid vehicle technology;
- demonstration of niche application battery electric vehicles, including school and transit buses and refuse trucks with short-distance fixed service routes;
- demonstration of integrated programs that make best use of electric drive vehicles through interconnectivity between fleets of electric vehicles and mass transit, and web-based reservation systems that allow multiple users;
- development of eco-friendly intelligent transportation system (ITS) strategies, optimized load-balancing strategies for cargo freight and market analysis for zero emission heavy-duty trucks;
- and
- demonstration and installation of EV infrastructure to support the electric and hybrid-electric vehicle fleets currently on the roads or soon entering the market, and to reduce cost, improve convenience and integrate with renewable energy and building demand management strategies (e.g., vehicle-to-grid or vehicle-to-building functionality).

Hydrogen & Fuel Cell Technologies & Infrastructure

The SCAQMD supports hydrogen infrastructure and fuel cell technologies as one option in our technology portfolio and is dedicated to assisting federal and state government programs to deploy light-duty fuel cell vehicles (FCVs) by supporting the required refueling infrastructure.

Calendar Years 2015-2018 are a critical timeframe for the introduction of hydrogen fueling infrastructure. In 2015, Toyota commercialized the first FCV available to consumers for purchase, in

2014, Hyundai introduced the Tuscon FCV for lease, and Honda started delivering its 2017 Honda Clarity Fuel Cell in December 2016, and other OEMs have similarly disclosed plans to commercialize FCVs in 2017 and 2018. Since hydrogen refueling stations need 18-36 month lead times for permitting, construction and commissioning, plans for stations need to be implemented now. While coordination efforts with the Division of Measurement Standards to establish standardized measurements for hydrogen fueling started in 2014, additional efforts to offer hydrogen for sale to general consumers are still needed. In addition, SCAQMD continues to review the market to understand new business models and new sources of funding besides grants for construction necessary to enable the station operations to remain solvent during the early years until vehicle numbers ramp up. Lastly, a deliberate and coordinated effort is necessary to ensure that the retail hydrogen stations are developed with design flexibility to address specific location limitations, and with refueling reliability matching those of existing gasoline and diesel fueling stations.

Fuel cells can also play a role in medium- and heavy-duty applications where battery capacity is insufficient to meet range requirements. The CaFCP's Medium- and Heavy-Duty Fuel Cell Electric Truck Action Plan completed in October 2016 focuses on Class 4 parcel delivery trucks and Class 8 drayage trucks with infrastructure development and establishes metrics for measuring progress.

The 2017 Plan Update identifies key opportunities while clearly leading the way for pre-commercial demonstrations of OEM vehicles. Future projects may include the following:

- continued development and demonstration of distributed hydrogen production and fueling stations, including energy stations with electricity and hydrogen co-production and higher pressure (10,000 psi) hydrogen dispensing and scalable/higher throughput;
 - development and demonstration of cross-cutting fuel cell applications (e.g. plug-in hybrid fuel cell vehicles);
 - development and demonstration of fuel cells in off-road, locomotive and marine applications;
 - demonstration of fuel cell vehicles in controlled fleet applications in the Basin; and
 - development and implementation of strategies with government and industry to build participation in the hydrogen market including certification and testing of hydrogen as a commercial fuel to create a business case for investing as well as critical assessments of market risks to guide and protect this investment.
- coordinate with fuel cell vehicle OEMs to develop an understanding of their progress in overcoming the barriers to economically competitive fuel cell vehicles and develop realistic scenarios for their large scale introduction.

Engine Systems

Natural gas engines are experiencing huge market growth due to the low cost of fuel. In order to achieve the emission reductions required for the South Coast Air Basin, the internal combustion engines (ICEs) used in the heavy-duty sector will require emissions that are 90% lower than the 2010 standards. This year the commercialization of the Cummins 8.9-liter natural gas engine achieving 90% below the existing federal standard was a game changer. By 2018, Cummins Westport, with SCAQMD and others as project partners, hopes to certify and commercialize a near-zero emission version of its existing 12-liter natural gas engine. The Draft 2017 Plan Update continues to incorporate pursuit of cleaner engines for the heavy-duty sector. Future projects will support the development, demonstration and certification of engines that can achieve these massive emission reductions using an optimized systems approach. Specifically, these projects are expected to target the following:

- development of ultra-low emission, natural gas engines for heavy-duty vehicles and high horsepower applications;
- continued development and demonstration of gaseous- and liquid-fueled, advanced fuels or alternative fuel medium-duty and heavy-duty engines and vehicles;
- development and demonstration of alternative fuel engines for off-road applications;

evaluation of alternative engine systems such as hydraulic plug-in hybrid vehicles; and development and demonstration of engine systems that employ advanced engine design features, waste heat recovery, improved exhaust or recirculation systems, and aftertreatment devices.

Development of cold start technologies for hybrids and diesels where high level emissions occur

The National Highway Traffic Safety Administration's finalized standards to improve fuel efficiency of medium- and heavy-duty vehicles for model year 2018 and beyond should spur further interest by manufacturers to partner on engine system development. The EPA's recent initiation to create a rule for a national low NO_x standard for all on highway heavy duty engines will require all manufacturers to participate by 2024

Fueling Infrastructure and Deployment (NG/RNG)

The importance of natural gas, renewable natural gas (RNG) and related refueling infrastructure cannot be overemphasized for the realization of large deployment of alternative fuel technologies. Significant demonstration and commercialization efforts funded by the Clean Fuels Program as well as other local, state and federal agencies are underway to: 1) support the upgrade and buildup of public and private infrastructure projects, 2) expand the network of public-access and fleet fueling stations based on the population of existing and anticipated vehicles, and 3) put in place infrastructure that will ultimately be needed to accommodate transportation fuels with very low gaseous emissions.

Compressed and liquefied natural gas (CNG and LNG) refueling stations are being positioned to support both public and private fleet applications. Upgrades and expansions are also needed to refurbish or increase capacity for some of the stations installed five or more years ago as well as standardize fueling station design, especially to ensure growth of alternative fuels throughout the South Coast Air Basin and beyond, along with partial or complete transition to renewable natural gas delivered through the pipeline. Funding has been provided at key refueling points for light-, medium- and heavy-duty natural gas vehicle users traveling from the local ports, along I-15 and The Greater Interstate Clean Transportation Corridor (ICTC) Network. SB 350 (De León) further establishes a target to double the energy efficiency in electricity and natural gas end uses by 2030.

Active participation in the development of National Fire Protection Association (NFPA) fire and safety codes and standards, evaluation of the cost and economics of the new fuels, public education and training and emergency response capability are just a few areas of the funded efforts that have overcome public resistance to these new technologies. Some of the projects expected to be developed and cofunded for infrastructure development are:

- development and demonstration of renewable natural gas as a vehicle fuel from renewable feedstocks and biowaste;
- development and demonstration of advanced, cost effective methods for manufacturing synthesis gas for conversion to renewable natural gas;
- enhancement of safety and emissions reduction from natural gas refueling equipment;
- expansion of fuel infrastructure, fueling stations, and equipment; and
- expansion of infrastructure connected with existing fleets, public transit, and transportation corridors, including demonstration and deployment of closed loop systems for dispensing and storage.

Health Impacts, Emissions and Fuel Studies

The monitoring of pollutants in the Basin is extremely important, especially when focused on (1) a particular sector of the emissions inventory (to identify the responsible technology) or (2) exposure to pollution (to assess the potential health risks). In fact, studies indicate that smoggy areas can produce irreversible damage to children's lungs. This information highlights the need for further emissions and

health studies to identify the emissions from high polluting sectors as well as the health effects resulting from these technologies.

Over the past few years, the SCAQMD has funded emission studies to evaluate the impact of tailpipe emissions of biodiesel and ethanol fueled vehicles mainly focusing on criteria pollutants and greenhouse gas (GHG) emissions. These studies showed that biofuels, especially biodiesel, can contribute to higher NO_x emissions while reducing other criteria pollutant emissions. Furthermore, despite recent advancements in toxicological research related to air pollution, the relationship between particle chemical composition and health effects is still not completely understood, especially for biofuels. Therefore, a couple of years ago the SCAQMD funded studies to investigate the physical and chemical composition and toxicological potential of tailpipe PM emissions from biodiesel and ethanol fueled vehicles to better understand their impact on public health. Studies continued in 2015 to further investigate the toxicological potential of emissions, such as ultrafine particles and vapor phase substances, and to determine whether or not other substances such as volatile or semi-volatile organic compounds are being emitted in lower mass emissions that could pose harmful health effects. In addition, as the market share for gasoline direct injection (GDI) vehicles has rapidly increased from 4% of all vehicle sales in the U.S. in 2009 to 38% in 2014, with an expectation to top 60% by 2016, it is important to understand the impact on air quality from these vehicles. As such, SCAQMD has either funded or will be funding studies to investigate both physical and chemical composition of tailpipe emissions, focusing on PM from GDI vehicles.

In recent years, there has also been an increased interest both at the state and national level on the use of alternative fuels including biofuels to reduce petroleum oil dependency, GHG emissions and air pollution. In order to sustain and increase biofuel utilization, it is essential to identify feedstocks that can be processed in a more efficient, cost-effective and sustainable manner. One such fuel that the Clean Fuels Program is interested in pursuing is dimethyl ether (DME). This synthetic fuel can be made from renewable natural gas resources and has characteristics similar to gas-to-liquids fuels, i.e., high cetane, zero aromatics and negligible emissions of particulate matter. Volvo has considered commercializing Class 8 trucks using DME, and staff would like to ensure these trucks have lower NO_x than the existing standard.

Some areas of focus include:

- demonstration of remote sensing technologies to target different high emission applications and sources;
- studies to identify the health risks associated with ultrafine and ambient particulate matter including their composition to characterize their toxicity and determine specific combustion sources;
- in-use emissions studies using biofuels, including DME to evaluate in-use emission composition;
- in-use emissions studies to determine the impact of new technologies, in particular PEVs on local air quality as well as the benefit of telematics on emissions reduction strategies;

lifecycle energy and emissions analyses to evaluate conventional and alternative fuels; and analysis of fleet composition and its associated impacts on criteria pollutants.

Stationary Clean Fuel Technologies

Although stationary source emissions are small compared to mobile sources in the South Coast Air Basin, there are applications where cleaner fuel technology can be applied to reduce NO_x, VOC and PM emissions. For example, a recent demonstration project funded in part by the SCAQMD at a local sanitation district consisted of retrofitting an existing biogas engine with a digester gas cleanup system and catalytic exhaust emission control. The retrofit system resulted in significant reductions in NO_x, VOC and CO emissions. This project demonstrated that cleaner, more robust renewable distributed generation technologies exist that could be applied to not only improve air quality, but enhance power quality and reduce electricity distribution congestion.

The use of renewable feedstocks for energy production is a possible option to provide sustainable power for future needs while reducing greenhouse gas emissions and achieving domestic energy diversity. One of the projects that the SCAQMD recently supported in this effort was a bench scale demonstration project using a steam hydrogasification process to produce natural gas from biomass and biosolid (sewage sludge) feedstocks. Steam Hydrogasification Reaction (SHR) has been developed to produce various forms of energy products from carbonaceous resources. SHR is capable of handling wet feedstocks like sludge, does not require expensive oxygen plants and has been demonstrated to be most efficient and cost-effective compared to other conventional gasification technologies. This project successfully demonstrated that the SHR process coupled with a water-gas shift (WGS) reactor can produce gas containing up to 90% methane.

Additionally, alternative energy storage could be achieved through vehicle-to-grid or vehicle-to-building technologies. The University of California Riverside's Sustainable Integrated Grid Initiative, funded in part by the SCAQMD and launched in 2014, for example could assist in the evaluation of these technologies. Projects conducted under this category may include:

- development and demonstration of reliable, low emission stationary technologies (e.g., low NOx burners, fuel cells or microturbines);
- exploration of renewables as a source for cleaner stationary technologies;
- evaluation, development and demonstration of advanced control technologies for stationary sources; and
- vehicle-to-grid or vehicle-to-building demonstration projects to develop sustainable, low emission energy storage alternatives.

Emission Control Technologies

Although engine technology and engine systems research is required to reduce the emissions at the combustion source, dual fuel technologies and post-combustion cleanup methods are also needed to address the current installed base of on-road and off-road technologies. Existing diesel emissions can be greatly reduced with introduction of natural gas into the engine or via aftertreatment controls such as particulate matter (PM) traps and catalysts, as well as lowering the sulfur content or using additives with diesel fuel. Gas-to-Liquid (GTL) fuels, formed from natural gas or other hydrocarbons rather than petroleum feedstock and emulsified diesel, provide low emission fuels for use in diesel engines. As emissions from engines become lower and lower, the lubricant contributions to VOC and PM emissions become increasingly important. The most promising of these technologies will be considered for funding, specifically:

- evaluation and demonstration of new emerging liquid fuels, including alternative and renewable diesel and GTL fuels;
- development and demonstration of dual fuel engines and advanced aftertreatment technologies for mobile applications (including diesel particulate traps and selective catalytic reduction catalysts); and non thermal regen technology
- development and demonstration of low-VOC and PM lubricants for diesel and natural gas engines.

Technology Assessment/Transfer & Outreach

Since the value of the Clean Fuels Program depends on the deployment and adoption of the demonstrated technologies, outreach and technology transfer efforts are essential to its success. This core area encompasses assessment of advanced technologies, including retaining outside technical assistance as needed, efforts to expedite the implementation of low emission and clean fuels technologies, coordination of these activities with other organizations and information dissemination to educate the end user. Technology transfer efforts include support for various clean fuel vehicle incentive programs as well.

Target Allocations to Core Technology Areas

Figure 40 below presents the potential allocation of available funding, based on SCAQMD projected program costs of \$16.5 million for all potential projects. The expected actual project expenditures for 2017 will be less than the total SCAQMD projected program cost since not all projects will materialize. The target allocations are based on balancing technology priorities, technical challenges and opportunities discussed previously and near-term versus long-term benefits with the constraints on available SCAQMD funding. Specific contract awards throughout 2017 will be based on this proposed allocation, the quality of proposals received and evaluation of projects against standardized criteria and ultimately SCAQMD Governing Board approval.

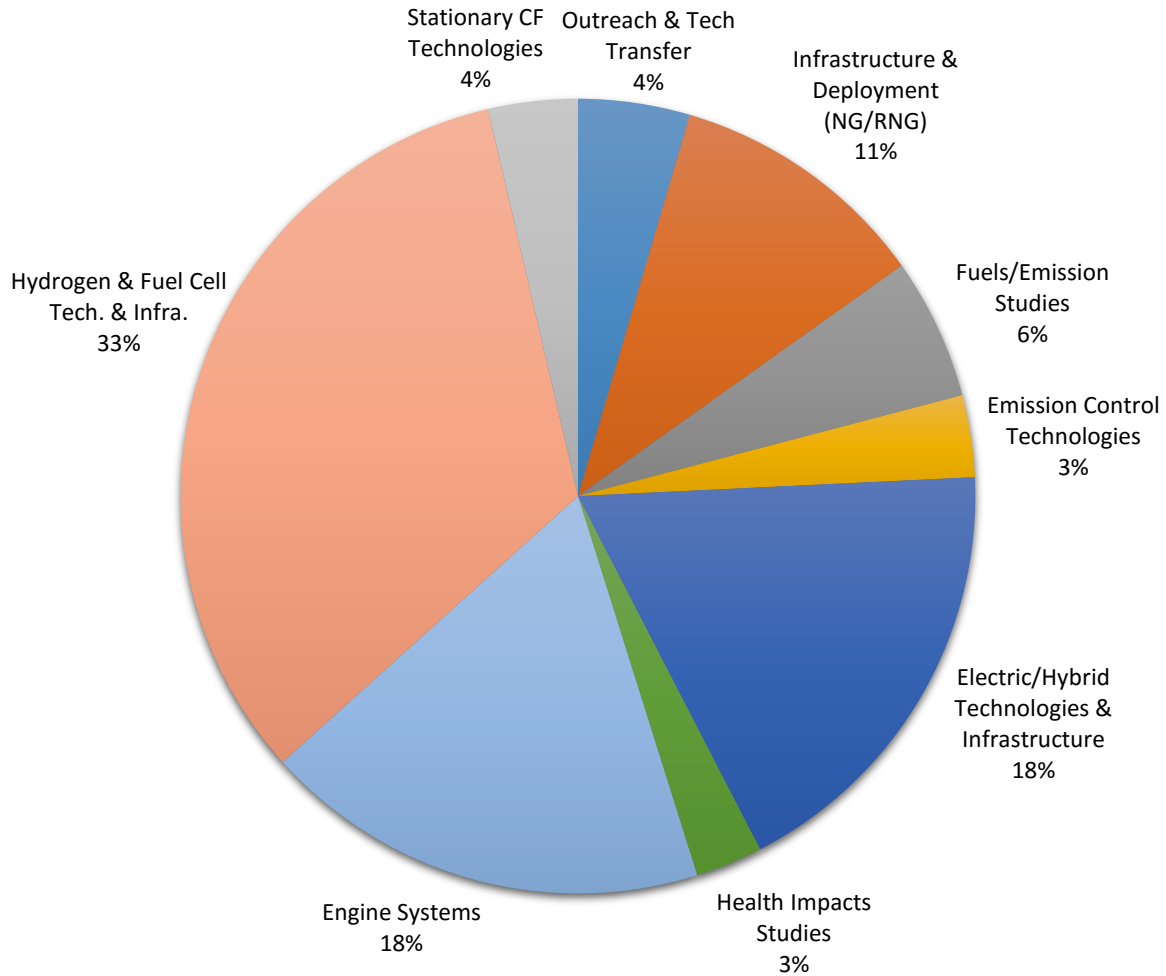

Figure 40: Projected Cost Distribution for Potential SCAQMD Projects in 2017 (\$16.5M)

Program Plan Update for 2017

This section presents the Clean Fuels Program Plan Update for 2017. The proposed projects are organized by program areas and described in further detail, consistent with the SCAQMD budget, priorities and the best available information on the state-of-the-technology. Although not required, this Plan also includes proposed projects that may be funded by revenue sources other than the Clean Fuels Program, specifically related to VOC and incentive projects.

Table 7 (page 79) summarizes potential projects for 2017 as well as the distribution of SCAQMD costs in some areas as compared to 2016. The funding allocation continues the focus toward development and demonstration of zero and near-zero emission technologies including the infrastructure for such technologies. For the 2017 Plan, the SCAQMD shifts some emphasis onto hydrogen and fuel cell technologies to incentivize large-scale hydrogen infrastructure projects at the Ports and in the Inland Empire and in light of current and projected roll out of fuel cell vehicles in 2016-2017, with a small decrease in electric and hybrid-electric technologies in light of the large award the SCAQMD received in early January 2016 from the Greenhouse Gas Reduction Fund Program. A small funding shift to Engine Systems and Fueling Infrastructure and Deployment (natural gas and renewable fuels) is also recommended for biogas production and to ensure continued development and deployment of near-zero natural gas engines and liquid-fueled high horsepower engines for long-haul trucks. The other areas will continue with similar allocations for 2017. As in prior years, the funding allocations again align well with the SCAQMD's FY 2016-17 Goals and Priority Objectives. Overall, the Program is designed to ensure a broad portfolio of technologies and leverage state and federal efforts, and maximize opportunities to leverage technologies in a synergistic manner.

Each of the proposed projects described in this Plan, once fully developed, will be presented to the SCAQMD Governing Board for approval prior to contract initiation. This development reflects the maturity of the proposed technology and identifies contractors to perform the projects, participating host sites, and securing sufficient cost-sharing needed to complete the project and other necessary factors. Recommendations to the SCAQMD Governing Board will include descriptions of the technology to be demonstrated and in what application, the proposed scope of work of the project and the capabilities of the selected contractor and project team, in addition to the expected costs and expected benefits of the projects as required by H&SC 40448.5.1.(a)(1). Based on communications with all of the organizations specified in H&SC 40448.5.1.(a)(2) and review of their programs, the projects proposed in this Plan do not appear to duplicate any past or present projects.

Funding Summary of Potential Projects

The remainder of this section contains the following information for each of the potential projects summarized in Table 7.

Proposed Project: A descriptive title and a designation for future reference.

Expected SCAQMD Cost: The estimated proposed SCAQMD cost share as required by H&SC 40448.5.1.(a)(1).

Expected Total Cost: The estimated total project cost including the SCAQMD cost share and the cost share of outside organizations expected to be required to complete the proposed project. This is an indication of how much SCAQMD public funds are leveraged through its cooperative efforts.

Description of Technology and Application: A brief summary of the proposed technology to be developed and demonstrated, including the expected vehicles, equipment, fuels, or processes that could benefit.

Potential Air Quality Benefits: A brief discussion of the expected benefits of the proposed project, including the expected contribution towards meeting the goals of the AQMP, as required by H&SC 40448.5.1.(a)(1). In general, the most important benefits of any technology research, development and demonstration program are not necessarily realized in the near-term. Demonstration projects are generally intended to be proof-of-concept for an advanced technology in a real-world application. While emission benefits, for example, will be achieved from the demonstration, the true benefits will be seen over a longer term, as a successfully demonstrated technology is eventually commercialized and implemented on a wide scale.

Table 7: Summary of Potential Projects for 2017

Proposed Project	Expected SCAQMD Cost \$	Expected Total Cost \$
Electric/Hybrid Technologies & Infrastructure		
Develop and Demonstrate Electric and Hybrid Vehicles	1,000,000	2,000,000
Develop and Demonstrate Infrastructure for Deployment of Plug-in Electric and Hybrid Electric Vehicles	700,000	3,000,000
Demonstrate Alternative Energy Storage	300,000	2,000,000
Develop and Demonstrate Electric Container Transport Technologies	1,000,000	4,000,000
Subtotal	\$3,000,000	\$11,000,000
Hydrogen and Fuel Cell Technologies and Infrastructure		
Develop and Demonstrate Operation and Maintenance Business Case Strategies for Hydrogen Stations	350,000	4,000,000
Develop and Demonstrate Hydrogen Production and Fueling Stations	2,000,000	6,000,000
Develop and Demonstrate Medium- and Heavy-Duty Fuel Cell Vehicles	3,000,000	10,000,000
Demonstrate Light-Duty Fuel Cell Vehicles	100,000	100,000
Subtotal	\$5,450,000	\$20,100,000
Engine Systems		
Develop and Demonstrate Advanced Gaseous- and Liquid-Fueled Medium- and Heavy-Duty Engines and Vehicle Technologies to Achieve Ultra-Low Emissions	2,300,000	5,600,000
Develop and Demonstrate Alternative Fuel and Clean Conventional Fueled Light-Duty Vehicles	200,000	1,500,000
Develop and Demonstrate Cold-Start Technologies	250,000	1,000,000
Develop and Demonstrate Waste-Heat Recovery on Heavy-Duty Diesel Engines	250,000	1,000,000
Subtotal	\$3,000,000	\$9,100,000
Fueling Infrastructure and Deployment (NG/RNG)		
Deploy Natural Gas Vehicles in Various Applications	500,000	2,000,000
Develop, Maintain & Expand Natural Gas Infrastructure	250,000	1,500,000
Demonstrate Natural Gas Manufacturing and Distribution Technologies Including Renewables	1,000,000	10,000,000
Subtotal	\$1,750,000	\$13,500,000
Fuels/Emission Studies		
Conduct In-Use Emissions Studies for Advanced Technology Vehicle Demonstrations	300,000	800,000
Conduct Emissions Studies on Biofuels and Alternative Fuels	400,000	1,000,000

Table 7: Summary of Potential Projects for 2017 (cont'd)

Proposed Project	Expected SCAQMD Cost \$	Expected Total Cost \$
Fuels/Emission Studies (cont'd)		
Identify and Demonstrate In-Use Fleet Emissions Reduction Technologies & Opportunities	250,000	2,000,000
Subtotal	\$950,000	\$3,800,000
Stationary Clean Fuel Technologies		
Develop and Demonstrate Reliable, Advanced Emission Control Technologies, and Low Emission Monitoring Systems and Test Methods	150,000	500,000
Develop and Demonstrate Clean Stationary Technologies	250,000	750,000
Develop and Demonstrate Renewables-Based Energy Generation Alternatives	200,000	1,000,000
Subtotal	\$600,000	\$2,250,000
Emission Control Technologies		
Develop and Demonstrate Advanced Aftertreatment Technologies	300,000	5,000,000
Demonstrate On-Road Technologies in Off-Road and Retrofit Applications	250,000	1,000,000
Subtotal	\$550,000	\$6,000,000
Health Impacts Studies		
Evaluate Ultrafine Particle Health Effects	150,000	2,000,000
Conduct Monitoring to Assess Environmental Impacts	150,000	500,000
Assess Sources and Health Impacts of Particulate Matter	150,000	300,000
Subtotal	\$450,000	\$2,800,000
Outreach and Technology Transfer		
Assess and Support Advanced Technologies and Disseminate Information	425,000	800,000
Support Implementation of Various Clean Fuels Vehicle Incentive Programs	325,000	400,000
Subtotal	\$750,000	\$1,200,000
TOTALS FOR POTENTIAL PROJECTS	\$16,500,000	\$ 69,750,000

Technical Summaries of Potential Projects

Electric/Hybrid Technologies & Infrastructure

Proposed Project: Develop and Demonstrate Electric and Alternative Fuel Transportation

Expected SCAQMD Cost: \$700,000

Expected Total Cost: \$2,000,000

Description of Technology and Application:

The significance of transportation in overall carbon emissions is increasing as energy utilities move toward cleaner and more sustainable ways to generate electricity. In the United States, the EPA estimated that in 2015, transportation was responsible for about 28% of the nation’s carbon emissions, second only to power plants at 31%.

The global light-duty vehicle market is changing rapidly on behalf of government-led initiatives to improve fuel economy and market demand for alternative transportation options. These changes are being driven primarily by the adoption of vehicles with various levels of drivetrain electrification. The SCAQMD has long supported the concept of using increased battery power to allow a portion of the driving cycle to occur in all-electric mode for true zero emission miles. This battery dominant strategy is accomplished by incorporating an advanced battery pack initially recharged from the household grid or EV chargers. This “plug-in” hybrid EV strategy allows reduced emissions and improved fuel economy. In 2009, CARB adopted Plug-In Hybrid Electric Vehicle Test Procedure Amendments and Aftermarket Parts Certification and several automobile manufacturers have announced demonstration or early production plans of “blended” plug-in hybrid electric, extended-range electric vehicles (E-rEV), or highway capable battery electric vehicles (BEVs). Electric utilities refer to PHEVs, E-rEVs and BEVs as plug-in electric drive vehicles (PEVs) and are working with automakers to support PEVs. Long-range BEVs are now competitive in price among economy brands after subsidies and the affordable 200+ mile BEV will have a big impact on the vehicle market. Plug-in hybrids (PHEVs) are also making significant advances. Continued market expansion is likely to result from expanding OEM applications of the powertrain in new, larger vehicle body types.

Recently, automakers have commercialized fuel cell vehicles, with some concepts with plug-in charge capability. Development and demonstration of dual fuel, zero emission vehicles could expand the acceptance of battery electric vehicles and accelerate the introduction of fuel cells in vehicle propulsion.

The SCAQMD has long been a leader in promoting early demonstrations of next generation light-duty vehicle propulsion technologies (and fuels). However, given the current and planned market offerings in this category, priorities have shifted. Nevertheless, the SCAQMD will continue to evaluate market offerings and proposed technologies in light-duty vehicles to determine if any future support is required.

Medium- and heavy-trucks make up 4.3% of vehicles in the United States and drive 9.3% of all miles driven each year, yet are responsible for more than 25% of all the fuel burned annually. However, hybrid technologies have gained momentum in the light-duty sector with commercial offerings by most of the automobile manufacturers. Unfortunately, the medium- and heavy-duty platforms are where most emissions reductions are required, especially for the in-use fleet due to low turnover.

Federal Recovery Act funding combined with state and local support, has accelerated the development and demonstration of medium-duty plug-in hybrid electric truck platforms. Analysis of project data and use profiles will help optimize drive systems, target applications for early commercialization and fill gaps in product offerings.

The SCAQMD has investigated the use of hybrid technologies to achieve similar performance as the conventional-fueled counterparts while achieving both reduced emissions and improved fuel economy. Development and validation of emission test procedures is needed, but is complicated due to the low volume and variety of medium- and heavy-duty vehicles.

Platforms to be considered include utility trucks, delivery vans, shuttle buses, transit buses, waste haulers, construction equipment, cranes and other off-road vehicles. Innovations that may be considered for demonstration include: advancements in the auxiliary power unit, either ICE or other heat engine; battery-dominant hybrid systems utilizing off-peak re-charging, with advanced battery technologies such as lithium-ion; and hydraulic energy storage technologies where applicable. Alternative fuels are preferred in these projects, e.g., natural gas, especially from renewable sources, LPG, hydrogen, GTL and hydrogen-natural gas blends, but conventional fuels such as gasoline, clean diesel, or even biodiesel may be considered if the emissions benefits can be demonstrated as equivalent or superior to alternative fuels. Both new designs and retrofit technologies and related charging infrastructure will be considered.

This project category is to develop and demonstrate:

- various PEV architectures;
- anticipated costs for such architectures;
- customer interest and preferences for each alternative;
- integration of the technologies into prototype vehicles and fleets;
- evaluation of any new promising light-duty vehicle propulsion technologies or fuels; and
- electric and hybrid-electric medium- and heavy-duty vehicles (e.g., utility trucks, delivery vans, shuttle buses, transit buses, waste haulers, construction equipment, cranes and other off-road vehicles)

Potential Air Quality Benefits:

The Draft 2016 AQMP identifies zero or near-zero emitting vehicles as a key attainment strategy. Plug-in HEV technologies have the potential to achieve near-zero emissions while retaining the range capabilities of a conventionally gasoline-fueled combustion engine vehicle, a key factor expected to enhance broad consumer acceptance. Given the variety of PEV systems under development, it is critical to determine the true emissions and performance utility compared to conventional vehicles. Successful demonstration of optimized prototypes would promise to enhance the deployment of near-ZEV and ZEV technologies.

Expected benefits include the establishment of criteria for emissions evaluations, performance requirements, and customer acceptability of the technology. This will help both regulatory agencies and OEMs to expedite introduction of zero and near-zero emitting vehicles in the South Coast Basin, which is a high priority of the AQMP.

Proposed Project: Develop and Demonstrate Infrastructure for Deployment of Plug-in Electric and Hybrid Electric Vehicles

Expected SCAQMD Cost: \$800,000

Expected Total Cost: \$3,000,000

Description of Technology and Application:

There is a critical need to address gaps in EV charging infrastructure which has resulted in a deficiency of EV charging infrastructure availability. Almost half (47%) of the 561,022 EVs sold in the U.S. were in California, and of those sales in California, it is estimated that almost half (45%) were in Southern California or the greater Los Angeles region. In addition, the California ZEV Action Plan, which was updated in 2016, calls for 1.5 million ZEVs by 2025, calling for an increase of about 200,000 ZEVs annually between now and 2025.

The recent adoption of revised recommended practice SAE J1772 enables passenger vehicles to charge from 110/120V AC (Level 1), 220/240V AC (Level 2), and faster 440/480V DC charging using a common conductive connector in 30 minutes or less in the U.S. and Europe. Together with the growing adoption of long range EVs, the technology and infrastructure of three fast DC charging systems (SAE combo, CHAdeMO and Tesla) are developing as well. Technological developments improving the driving range of EVs, as well as increasing availability and speed of charging infrastructure, could change the need for charging infrastructure in the future. SCAQMD is committed to continuing to support the successful deployment of EV charging infrastructure.

The SCAQMD is actively pursuing development of intelligent transportation systems to improve traffic efficiency of electric and hybrid cargo container trucks. This system provides truck drivers real-time vehicle operation advice based on changing traffic and road conditions where trucks can dynamically change their speed to better flow through intersections. A truck eco-routing system can provide the most eco-friendly travel route based on truck engine/emission control characteristics, loaded weight, road grade and real-time traffic conditions. Integrated programs can interconnect fleets of electric drive vehicles with mass transit via Web-based reservation systems that allow multiple users. These integrated programs can match the features of EVs (zero emissions, zero start-up emissions, short range) to typical consumer demands for mobility in a way that significantly reduces emissions of pollutants and greenhouse gases.

This project category is one of SCAQMD's continued efforts to:

- deploy a network of DC fast charging infrastructure and rapidly expand the existing network of public plug-in EV charging stations;
- develop intelligent transportation system strategies for cargo containers;
- develop freight load-balancing strategies as well as to conduct market analysis for zero emission heavy-duty trucks in goods movement; and
- support for local government outreach and charging installation permit streamlining.

Potential Air Quality Benefits:

The Draft 2016 AQMP identifies zero or near-zero emitting vehicles as a key attainment strategy. Hybrid technologies have the potential to redirect previously wasted kinetic energy into useable vehicle power. This proposed project category will reduce Particulate Matter (PM) pollution along major roadways through the expansion of the public plug-in EV charging infrastructure network by allowing drivers to shift away from petroleum-fueled vehicles to plug-in EVs. In addition, this project will assist in achieving improved fuel economy and lower tailpipe emissions, further helping the region to achieve federal ambient air quality standards and protect public health. Expected benefits include the establishment of criteria for emissions evaluations, performance requirements and customer acceptability of the technology. This will help both regulatory agencies and OEMs to expedite

introduction of near-zero emitting vehicles in the South Coast Basin, which is a high priority of the AQMP.

Proposed Project: Demonstrate Alternative Energy Storage

Expected SCAQMD Cost: \$300,000

Expected Total Cost: \$2,000,000

Description of Technology and Application:

The SCAQMD has been involved in the development and demonstration of energy storage systems for electric and hybrid-electric vehicles, mainly Lithium ion chemistry battery packs. Over the past few years, additional technology consisting of nickel sodium chloride, lithium-ion and lithium iron phosphate batteries have shown robust performance. Other technology manufacturers have also developed energy storage devices including beyond lithium-ion batteries, flywheels, hydraulic systems and ultracapacitors. Energy storage systems optimized to combine the advantages of ultracapacitors and high-energy but low-power advanced batteries could yield further benefits. Beyond lithium-ion batteries (e.g., lithium-sulfur, lithium-oxygen, sodium-ion, flow, and solid-state batteries) also have opportunities to achieve higher energy density, longer cycle life, and cheaper cost.

This project category is to apply these advanced storage technologies in vehicle platforms to identify best fit applications, demonstrate their viability (reliability, maintainability and durability), gauge market preparedness and provide a pathway to commercialization.

The long-term objective of this project is to decrease fuel consumption and resulting emissions without any changes in performance compared to conventional vehicles. This effort will support several projects for development and demonstration of different types of low emission hybrid vehicles using advanced energy strategies and conventional or alternative fuels. The overall net emissions and fuel consumption of these types of vehicles are expected to be much lower than traditional engine systems. Both new and retrofit technologies will be considered.

Potential Air Quality Benefits:

Certification of low emission vehicles and engines and their integration into the Basin's transportation sector is a high priority under the Draft 2016 AQMP. This project is expected to further efforts to develop alternative energy storage technologies that could be implemented in medium- and heavy-duty trucks, buses and other applications. Benefits will include proof of concept for the new technologies, diversification of transportation fuels and lower emissions of criteria, toxic pollutants and greenhouse gases.

Proposed Project: Develop and Demonstrate Electric Container Transport Technologies

Expected SCAQMD Cost: \$1,200,000

Expected Total Cost: \$4,000,000

Description of Technology and Application:

Advanced transportation systems can be used to transfer cargo containers from ports to both local and “distant” intermodal facilities, thereby significantly reducing emissions from on-road trucks and locomotives and also reducing traffic congestion in local transportation corridors. Such systems could be stand-alone systems that use magnetic levitation (maglev), linear synchronous motors or linear induction motors on dedicated guideways. A more near-term design could use existing roadways that are electrified with catenary electric lines or linear electric motors to move containers on modified trucks equipped to run on electricity. In both scenarios, containers are transported relatively quietly and without direct emissions. The footprints for such systems are similar to conventional rail systems but have reduced impact on adjacent property owners including noise and fugitive dust. These systems can even be built above or adjacent to freeways or on elevated guideways. These container freight systems are not designed to carry any operators on the guideways, where the over-the-roadway system may require the operator to actively control the transport of the containers.

One of the container transportation concepts the SCAQMD is actively pursuing is the eHighway catenary hybrid truck system by Siemens Mobility. Siemens and their partners have developed a catenary system and hybrid electric trucks to utilize the catenary for zero emission transport of containers. The hybrid drive system will extend the operating range of the truck beyond the all-electric range of the catenary system, thus enabling the truck to perform regional drayage operations and bridge gaps in catenary infrastructure as it is deployed on a regional level. The proposed Siemens pantograph system will allow for seamless connection and disconnection from the catenary wires. When entering the catenary system corridor, the pantograph system will verify the presence of catenary lines and allow the driver to raise the pantograph from within the cab of the truck. Upon leaving the catenary system, the pantograph automatically retracts and the truck switches to on-board power systems. The on-board power systems could be a range of technologies, including batteries, fuel cells, or internal combustion engines. In addition, SCAQMD is administering a project to develop and demonstrate zero emission drayage trucks for goods movement operations, consisting of three different battery electric truck technologies and a fuel cell hybrid electric truck platform. This project is funded by a \$4.2 million award from Department of Energy to promote the deployment of zero emission cargo transport technologies. These trucks can be also upfitted to connect to wayside power via a catenary or LSM system in the future. Recently, CARB awarded SCAQMD more than \$23 million towards the development, demonstration and deployment of up to 43 trucks for goods movement, either with all electric operation or all electric range within disadvantaged communities. The total project cost is approximately \$40 million, with the remainder funds cost-shared between five sister air quality agencies, OEMs and demonstration sites.

In addition to these technologies, there are other options for electric container applications such as dual-mode locomotives, hybrid electric technologies with battery storage, a battery tender car, magnetic levitation, fuel cell propulsion systems and other wayside power alternatives. This technical review will evaluate all available technology options to determine whether their systems can be successfully developed and deployed, financially viable, and reliably operated on a long-term basis.

Potential Air Quality Benefits:

On-road heavy-duty diesel truck travel is an integral part of operations at the ports moving cargo containers into the Basin and beyond. The Draft 2016 AQMP proposes to reduce emissions from this activity by modernizing the fleet and retrofitting NOx and PM emission controls on older trucks. An alternative approach, especially for local drayage to the nearby intermodal facilities, is to use advanced

container transport systems that use electric propulsion for the containers on fixed guideways or modified trucks able to operate on electricity which will eliminate local diesel truck emissions. The emission benefits have not yet been estimated because the fate of the displaced trucks has not been determined.

Hydrogen and Fuel Cell Technologies & Infrastructure

Proposed Project: Develop and Demonstrate Operation and Maintenance Business Case Strategies for Hydrogen Stations

Expected SCAQMD Cost: \$350,000

Expected Total Cost: \$4,000,000

Description of Technology and Application:

California regulations require automakers to place increasing numbers of zero emission vehicles into service every year. By 2050, CARB projects that 87% of light-duty vehicles on the road will be zero emission battery and fuel cell vehicles with fuel cell electric becoming the dominant powertrain.

In 2013, cash-flow analysis resulting in a Hydrogen Network Investment Plan and fuel cell vehicle development partnership announcements by major automakers enabled the passage of AB 8 which provides \$20 million per year for hydrogen infrastructure cofunding through the CEC. This resulted in limited fuel cell vehicle production announcements by Hyundai, Toyota and Honda in 2014-2015.

In mid-2014, the CaFCP published the *Hydrogen Progress, Priorities and Opportunities* (HyPPO) report, an update of their roadmap describing the first network of commercial hydrogen stations in California. In October 2016, the CaFCP released its Medium- and Heavy-Duty Fuel Cell Electric Truck Action Plan focusing on Class 4 parcel delivery trucks and Class 8 drayage trucks with infrastructure development and establishing metrics for measuring progress.

In 2015, Hyundai and Toyota commercialized fuel cell vehicles, with Honda initiating delivery in 2016 and others to follow soon.

Government actions over the last couple of years, coupled with early adopter response, is helping to establish demand and thus a business case model for hydrogen stations. Additional work in this project category includes developing a plan to secure long-term funding to complete the hydrogen fueling network build-out, provide details how funding can be invested, assess alternative revenue streams such as renewable incentives, propose alternative financing structures to leverage/extend CEC funding, and support station operation during the transition to commercial viability, including optimizing designs with flexibility to address individual site characteristics, as well as ensuring higher levels of dispensing availability and reliability. Furthermore, in the next couple of years an evaluation of actual market penetration of FCVs should be conducted to guide and protect local and state investments in the hydrogen market.

Potential Air Quality Benefits:

The Draft 2016 AQMP identifies the use of alternative fuels and zero emission transportation technologies as necessary to meet federal air quality standards. One of the major advantages of Fuel Cell vehicles (FCEVs) is the fact that they use hydrogen, a fuel that can be domestically produced from a variety of resources such as natural gas, electricity (stationary turbine technology, solar or wind) and biomass. The technology and means to produce hydrogen fuel to support FCEVs are available now. The deployment of large numbers of FCEVs, which is an important strategy to attain air quality goals, requires a well-planned and robust hydrogen fueling infrastructure. This SCAQMD project, with significant additional funding from other governmental and private entities, will provide the hydrogen fueling infrastructure that is necessary in the South Coast Air Basin. The deployment of FCEVs and the development of the necessary fueling infrastructure will lead to substantial reductions in NO_x, VOC, CO, PM and toxic air contaminants from vehicles.

Proposed Project: Develop and Demonstrate Distributed Hydrogen Production and Fueling Stations**Expected SCAQMD Cost:** \$2,000,000**Expected Total Cost:** \$6,000,000**Description of Technology and Application:**

Alternative fuels, such as hydrogen and the use of advanced technologies, such as fuel cell vehicles, are necessary to meet future clean air standards. A key element in the widespread acceptance and resulting increased use of alternative fuel vehicles is the development of a reliable and robust infrastructure to support the refueling of vehicles, cost-effective production and distribution and clean utilization of these new fuels.

A major challenge to the entry and acceptance of direct-hydrogen fuel cell vehicles is the limited number of hydrogen refueling sites. This project would support the development and demonstration of hydrogen refueling technologies. Proposed projects would address:

Fleet and Commercial Refueling Stations: Further expansion of the hydrogen fueling network based on retail models, providing renewable generation, adoption of standardized measurements for hydrogen refueling, other strategic refueling locations and increased dispensing pressure of 10,000 psi and compatibility with existing CNG stations may be considered.

Energy Stations: Multiple-use energy stations that can produce hydrogen for fuel cell vehicles or for stationary power generation are considered an enabling technology with the potential for costs competitive with large-scale reforming. System efficiency, emissions, hydrogen throughput, hydrogen purity and system economics will be monitored to determine the viability of this strategy for hydrogen fueling infrastructure deployment and as a means to produce power and hydrogen from renewable feedstocks (e.g., biomass, digester gas).

Home Refueling Appliances: Home refueling/recharging is an attractive advancement for alternative clean fuels due to the limited conventional refueling infrastructure. This project would evaluate a hydrogen home refueler for cost, compactness, performance, durability, emission characteristics, ease of assembly and disassembly, maintenance and operations. Other issues such as building permits, building code compliance and UL ratings for safety would also be evaluated.

It is estimated that approximately 13,500 fuel cell vehicles will be deployed by 2019 in California and the majority of these vehicles will be in the South Coast Air Basin. To provide fuel for these vehicles, the hydrogen fueling infrastructure needs to be significantly increased and become more reliable in terms of availability. SCAQMD will seek additional funding from CEC and CARB to construct and operate hydrogen fueling stations.

Potential Air Quality Benefits:

The Draft 2016 AQMP identifies the use of alternative clean fuels in mobile sources as a key attainment strategy. Pursuant to AQMP goals, the SCAQMD has in effect several fleet rules that require public and certain private fleets to purchase clean-burning alternative-fueled vehicles when adding or replacing vehicles to their vehicle fleets. Fuel cell vehicles constitute the cleanest alternative-fuel vehicles today. Since hydrogen is a key fuel for fuel cell vehicles, this project would address some of the barriers faced by hydrogen as a fuel and thus assist in accelerating its acceptance and ultimate commercialization. In addition to supporting the immediate deployment of the demonstration fleet, expanding the hydrogen fuel infrastructure should contribute to the market acceptance of fuel cell technologies in the long run, leading to substantial reductions in NO_x, VOC, CO, PM and toxic compound emissions from vehicles.

Proposed Project: Develop and Demonstrate Medium- and Heavy-Duty Fuel Cell Vehicles

Expected SCAQMD Cost: \$3,000,000

Expected Total Cost: \$10,000,000

Description of Technology and Application:

This proposed project would support evaluation including demonstration of promising fuel cell technologies for applications using direct hydrogen with proton exchange membrane (PEM) fuel cell technology. Battery dominant fuel cell hybrids are another potential technology being mentioned by battery experts as a way of reducing costs and enhancing performance of fuel cell vehicles.

The California ZEV Action Plan specifies actions to help deploy an increasing number of zero emission vehicles, including medium- and heavy-duty ZEVs. Fleets are useful demonstration sites because economies of scale exist in central refueling, in training skilled personnel to operate and maintain the vehicles, in the ability to monitor and collect data on vehicle performance and for manufacturer technical and customer support. In some cases, medium- and heavy-duty fuel cell vehicles could leverage the growing network of hydrogen stations, providing an early base load of fuel consumption until the number of passenger vehicles grows. These vehicles could include hybrid-electric vehicles powered by fuel cells and equipped with batteries capable of being charged from the grid and even supplying power to the grid.

In 2012, the DOE awarded SCAQMD funds to demonstrate Zero Emission Container Transport (ZECT) technologies. In 2015, the DOE awarded SCAQMD additional funds to develop and demonstrate additional fuel cell truck platforms and vehicles under ZECT II.

This category may include projects in the following applications:

On-Road:	Off-Road:
Transit Buses	Vehicle Auxiliary Power Units
Shuttle Buses	Construction Equipment
Medium- & Heavy-Duty Trucks	Lawn and Garden Equipment
	Cargo Handling Equipment

Potential Air Quality Benefits:

The Draft 2016 AQMP identifies the need to implement zero emission vehicles. SCAQMD adopted fleet regulations require public and some private fleets within the Basin to acquire alternatively fueled vehicles when making new purchases. In the future, such vehicles could be powered by zero emission fuel cells operating on hydrogen fuel. The proposed projects have the potential to accelerate the commercial viability of fuel cell vehicles. Expected immediate benefits include the establishment of zero- and near-zero emission proof-of-concept vehicles in numerous applications. Over the longer term, the proposed projects could help foster wide-scale implementation of zero emission fuel cell vehicles in the Basin. The proposed projects could also lead to significant fuel economy improvements, manufacturing innovations and the creation of high-tech jobs in Southern California, besides realizing the air quality benefits projected in the AQMP.

Proposed Project: Demonstrate Light-Duty Fuel Cell Vehicles

Expected SCAQMD Cost: \$100,000

Expected Total Cost: \$100,000

Description of Technology and Application:

This proposed project would support the demonstration of limited production and early commercial fuel cell passenger vehicles using gaseous hydrogen with proton exchange membrane (PEM) fuel cell technology, mainly through showcasing this technology. Recent designs of light-duty fuel cell vehicles include hybrid batteries to recapture regenerative braking and improve overall system efficiency.

With the implementation of the California ZEV Action Plan, supplemented by the existing and planned hydrogen refueling stations in the Southern California area, light-duty fuel cell limited-production vehicles are planned for retail deployment in early commercial markets near hydrogen stations by several automakers. Fleets are useful demonstration sites because economies of scale exist in central refueling, in training skilled personnel to operate and maintain the vehicles, in the ability to monitor and collect data on vehicle performance and for manufacturer technical and customer support. SCAQMD has included fuel cell vehicles as part of its demonstration fleet since our first hydrogen station began operation in 2005; strengthening support, education, and outreach regarding fuel cell vehicle technology on an on-going basis. In addition, demonstration vehicles could include hybrid-electric vehicles powered by fuel cells and equipped with larger batteries capable of being charged from the grid and even supplying power to the grid.

Recently, Hyundai, Toyota and Honda have commercialized fuel cell vehicles in California, with Mercedes-Benz announcing a plug-in fuel cell model for 2018. Innovative strategies and demonstration of dual fuel, zero emission vehicles could expand the acceptance of battery electric vehicles and accelerate the introduction of fuel cells in vehicle propulsion.

Potential Air Quality Benefits:

The Draft 2016 AQMP identifies the need to implement zero emission vehicles. SCAQMD adopted fleet regulations require public and some private fleets within the Basin to acquire alternatively fueled vehicles when making new purchases. In the future, such vehicles could be powered by zero emission fuel cells operating on hydrogen fuel. The proposed projects have the potential to accelerate the commercial viability of fuel cell vehicles. Expected immediate benefits include the deployment of zero-emission vehicles in SCAQMD's demonstration fleet. Over the longer term, the proposed projects could help foster wide-scale implementation of zero emission fuel cell vehicles in the Basin. The proposed projects could also lead to significant fuel economy improvements, manufacturing innovations and the creation of high-tech jobs in Southern California, besides realizing the air quality benefits projected in the AQMP.

Engine Systems

Proposed Project: Develop and Demonstrate Advanced Gaseous- and Liquid-Fueled Medium- and Heavy-Duty Engines and Vehicles

Expected SCAQMD Cost: \$2,800,000

Expected Total Cost: \$5,600,000

Description of Technology and Application:

The objective of this proposed project is to support development and certification of near commercial prototype low-emission medium- and heavy-duty gaseous- and liquid-fueled engine technologies and integration and demonstration of these technologies in on-road vehicles. The NO_x emissions target for this project area is 0.02 g/bhp-hr and lower and the PM emissions target is below 0.01 g/bhp-hr. To achieve these targets, an effective emission control strategy must employ advanced fuel system and engine design features, aggressive engine calibration and improved thermal management, improved exhaust gas recirculation systems, and aftertreatment devices that are optimized using a system approach. This effort is expected to result in several projects, including:

- Development and demonstration of advanced engines in medium- and heavy-duty vehicles and high horsepower applications;
- development of durable and reliable retrofit technologies to partially or fully convert engines and vehicles from petroleum fuels to alternative fuels; and
- anticipated fuels for these projects include but are not limited to alternative fuels (fossil fuel-based and renewable natural gas, propane, hydrogen blends, electric and hybrid), conventional and alternative diesel fuels, ultra-low sulfur diesel, emulsified diesel, dimethyl ether and gas-to-liquid fuels. The project proposes to expand field demonstration of these advanced technologies in various vehicle fleets operating with different classes of vehicles.

The use of alternative fuel in heavy-duty trucking applications has been demonstrated in certain local fleets within the Basin. These vehicles typically require 200-400 horsepower engines. Higher horsepower alternative fuel engines are beginning to be introduced. However, vehicle range, lack or limited accessible public infrastructure, lack of experience with alternative fuel engine technologies and limited selection of appropriate alternative fuel engine products have made it difficult for more firms to consider significant use of alternative fuel vehicles. For example, in recent years, several large trucking fleets have expressed interest in using alternative fuels. However, at this time the choice of engines over 400 HP or more is limited. Continued development of cleaner dedicated alternative gaseous- or diesel-fueled engines over 400 HP would increase availability to end-users and provide additional emission reductions.

Potential Air Quality Benefits:

This project is intended to expedite the commercialization of low-emission gaseous- liquid-fueled medium- and heavy-duty engine technology in California, both in the Basin and in intrastate operation. The emission reduction benefit of replacing one 4.0 g/bhp-hr heavy-duty engine with a 0.2 g/bhp-hr engine in a vehicle that consumes 10,000 gallons of fuel per year is about 1,400 lb/yr of NO_x. Clean neat or blended alternative fuels can also reduce heavy-duty engine particulate emissions by over 90 percent compared to current diesel technology. This project is expected to lead to increased availability of low-emission alternative fuel heavy-duty engines. Fleets can use the engines and vehicles emerging from this project to comply with SCAQMD fleet regulations.

Proposed Project: Develop and Demonstrate Alternative Fuel and Clean Conventional Fueled Light-Duty Vehicles

Expected SCAQMD Cost: \$200,000

Expected Total Cost: \$1,500,000

Description of Technology and Application:

Although new conventionally fueled vehicles are much cleaner than their predecessors, not all match the lowest emissions standards often achieved by alternative fuel vehicles. This project would assist in the development, demonstration and certification of both alternative-fueled and conventional-fueled vehicles to meet the strictest emissions requirements by the state, e.g., SULEV for light-duty vehicles. The candidate fuels include CNG, LPG, ethanol, GTL, clean diesel, bio-diesel and ultra low-sulfur diesel, and compressed air technologies. The potential vehicle projects may include:

- certification of CNG light-duty sedans and pickup trucks used in fleet services;
- assessment of “clean diesel” vehicles, including hybrids and their ability to attain SULEV standards; and
- assessment of compressed air technologies.

Other fuel and technology combinations may also be considered under this category.

Potential Air Quality Benefits:

The Draft 2016 AQMP identifies the use of alternative clean fuels in mobile sources as a key attainment strategy. Pursuant to AQMP goals, the SCAQMD has in effect several fleet rules that require public and certain private fleets to purchase clean-burning alternative-fueled vehicles when adding or replacing vehicles to their vehicle fleets. This project is expected to lead to increased availability of low emission alternative-and conventional-fueled vehicles for fleets as well as consumer purchase.

Fueling Infrastructure and Deployment (NG/RNG)

Proposed Project: Deploy Natural Gas Vehicles in Various Applications

Expected SCAQMD Cost: \$500,000

Expected Total Cost: \$2,000,000

Description of Technology and Application:

Natural gas vehicles (NGVs) have been very successful in reducing emissions in the South Coast Air Basin due to the deployment of fleets and heavy-duty vehicles utilizing this clean fuel. In order to maintain the throughput, utility and commercial potential of the natural gas infrastructure and the corresponding clean air benefits, deploying additional models of NGVs in existing applications are needed. This technology category seeks to support the implementation of early-commercial vehicles in a wide variety of applications, such as taxis, law enforcement vehicles, shuttle buses, delivery vans, transit buses, waste haulers, class 8 tractors and off-road equipment such as construction vehicles and yard hostlers. It also seeks to deploy low-emission natural gas vehicles using renewable fuels to achieve further emission reductions.

Potential Air Quality Benefits:

Natural gas vehicles have inherently lower engine criteria pollutant emissions than conventional vehicles, especially in the heavy-duty applications where older diesel engines are being replaced. Incentivizing these vehicles in city fleets, goods movement applications and transit bus routes help to reduce the local emissions and exposure to nearby residents. Natural gas vehicles also can have lower greenhouse gas emissions and increase energy diversity depending on the feedstock and vehicle class. Deployment of additional NGVs is in agreement with SCAQMD's AQMP as well as the state's Alternative Fuels Plan as part of AB 1007 (Pavley).

Proposed Project: Develop, Maintain & Expand Natural Gas Infrastructure

Expected SCAQMD Cost: \$250,000

Expected Total Cost: \$1,500,000

Description of Technology and Application:

This project supports the development, maintenance and expansion of natural gas fueling station technologies and incorporate advancing concepts to increase the overall number of such fueling stations in strategic locations throughout the Basin including the Ports, reduce the cost of natural gas equipment, develop and demonstrate closed loop systems for dispensing and storage, standardize fueling station design and construction and help with the implementation of SCAQMD's fleet rules. As natural gas fueling equipment begins to age or has been placed in demanding usage, components begin to age and deteriorate. This project offers an incentive to facilities to replace worn-out equipment or to upgrade existing fueling and/or garage and maintenance equipment to offer increased fueling capacity to public agencies, private fleets and school districts.

Potential Air Quality Benefits:

The AQMP identifies the use of alternative clean fuels in mobile sources as a key attainment strategy. NGVs have significantly lower emissions than gasoline vehicles and represent the cleanest internal combustion engine powered vehicles available today. The project has the potential to significantly reduce the installation and operating costs of NGV refueling stations, besides improving the refueling time. While new or improved NGV stations have an indirect emissions reduction benefit, they help facilitate the introduction of low emission, NGVs in private and public fleets in the area, which have a direct emissions reduction benefit. The increased exposure and fleet and consumer acceptance of NGVs would lead to significant and direct reductions in NO_x, VOC, CO, PM and toxic compound emissions from mobile sources. Such increased penetration of NGVs will provide direct emissions reductions of NO_x, VOC, CO, PM and air toxic compounds throughout the Basin.

Proposed Project: Demonstrate Natural Gas Manufacturing and Distribution Technologies Including Renewables

Expected SCAQMD Cost: \$1,000,000

Expected Total Cost: \$10,000,000

Description of Technology and Application:

Lack of sufficient statewide LNG production results in increased fuel costs and supply constraints. The cost of transporting LNG from production facilities out-of-state increases the fuel cost anywhere from 15 to 20 cents per gallon of LNG and subjects users to the reliability of a single supply source. High capital costs prevent construction of closer, large scale liquefaction facilities. Small-scale, distributed LNG liquefaction systems may provide 25 percent lower capital costs than conventional technology per gallon of LNG produced. Because these smaller plants can be sited near fleet customers, costs for transporting the LNG to end users are much lower than those for remote larger plants. Beyond these cost reductions, the smaller plants offer key benefits of much smaller initial capital investment and wider network of supply than the larger plant model. Renewable feed stocks including landfill gas, green waste and waste gases can be processed to yield LNG or CNG.

Industry and government agree that LNG promises to capture a significant share of the heavy-duty vehicle and engine market. LNG is preferred for long distance trucking as it provides twice the energy per unit volume as CNG. This translates to longer driving ranges and lower-weight vehicle fuel storage.

The main objectives of this project are to investigate, develop and demonstrate:

- commercially viable methods for converting renewable feed stocks into CNG or LNG (e.g., production from biomass);
- economic small-scale natural gas liquefaction technologies;
- utilization of various gaseous feed stocks locally available;
- commercialize incentives for fleets to site, install and use LNG and L/CNG refueling facilities; and
- strategic placement of LNG storage capacity sufficient to provide supply to users in the event of a production outage.

Potential Air Quality Benefits:

The SCAQMD relies on a significant increase in the penetration of zero- and low-emission vehicles in the South Coast Basin to attain federal clean air standards by 2014, 2023 and 2032. This project would help develop a number of small-scale liquefaction technologies that can reduce LNG costs to be competitive with diesel fuel. Such advances are expected to lead to greater infrastructure development. This would make LNG fueled heavy-duty vehicles more available to the commercial market leading to direct reductions in NOx, PM and toxic compound emissions.

Fuels/Emission Studies

Proposed Project: Conduct In-Use Emissions Studies for Advanced Technology Vehicle Demonstrations

Expected SCAQMD Cost: \$300,000

Expected Total Cost: \$800,000

Description of Technology and Application:

Hybrid electric, hybrid hydraulic, plug-in electric hybrid and pure EVs will all play a unique role in the future of transportation. Each of these transportation technologies has attributes that could provide unique benefits to different transportation sectors. Identifying the optimal placement of each transportation technology will provide the co-benefits of maximizing the environmental benefit and return on investment for the operator.

The environmental benefit for each technology class will be highly duty-cycle and application specific. Identifying the attributes of a specific application or drive cycle that would take best advantage of a specific transportation technology would speed the adoption and make optimal use of financial resources in the demonstration and deployment of a technology. The adoption rates would be accelerated since the intelligent deployment of a certain technology would ensure that a high percentage of the demonstration vehicles showed positive results. These positive results would spur the adoption of this technology in similar applications, as opposed to negative results derailing the further development or deployment of a certain technology.

The proposed project would review and potentially coordinate application specific drive cycles for specific applications. The potential emissions reductions and fossil fuel displacement for each technology in a specific application would be quantified on a full-cycle basis. This information could be used to develop a theoretical database of potential environmental benefits of different transportation technologies when deployed in specific applications.

Another proposed project would be the characterization of intermediate volatility organic compound (IVOC) emissions which is critical in assessing ozone and SOA precursor production rates. Diesel vehicle exhaust and unburned diesel fuel are major sources of and contribute to the formation of urban ozone and secondary organic aerosol (SOA), which is an important component of PM_{2.5}.

Finally, while early developments in autonomous and vehicle-to-vehicle controls are focused on light-duty passenger vehicles, the early application of this technology to heavy-duty, drayage and container transport technologies is more likely. The impact on efficiency and emissions could be substantial. A project to examine this technology to assess its effect on goods movement and emissions associated with goods movement could be beneficial at this time.

Potential Air Quality Benefits:

The development of an emissions reduction database, for various application specific transportation technologies, would assist in the targeted deployment of new transportation technologies. This database coupled with application specific vehicle miles traveled and population data would assist in intelligently deploying advanced technology vehicles to attain the maximum environmental benefit. These two data streams would allow vehicle technologies to be matched to an application that is best suited to the specific technology, as well as selecting applications that are substantial enough to provide a significant environmental benefit. The demonstration of a quantifiable reduction in operating cost through the intelligent deployment of vehicles will also accelerate the commercial adoption of the various technologies. The accelerated adoption of lower emitting vehicles will further assist in attaining SCAQMD's air quality goals.

Proposed Project: Conduct Emissions Studies on Biofuels and Alternative Fuels

Expected SCAQMD Cost: \$400,000

Expected Total Cost: \$1,000,000

Description of Technology and Application:

The use of biofuels can be an important strategy to reduce petroleum dependency, air pollution and greenhouse gas emissions. Biofuels are in fact receiving increased attention due to national support and state activities resulting from AB 32, AB 1007 and the Low-Carbon Fuel Standard. With an anticipated increase in biofuel use, it is the objective of this project to further analyze these fuels to better understand their benefits and impacts not only on greenhouse gases but also on air pollution and associated health effects.

In various diesel engine studies, replacement of petroleum diesel fuel with biodiesel fuel has demonstrated reduced PM, CO and air toxics emissions. Biodiesel also has the potential to reduce greenhouse gas emissions because it can be made from renewable feedstocks, such as soy and canola. However, certain blends of biodiesel have a tendency to increase NOx emissions, which exacerbates the ozone and PM2.5 challenges faced in the Basin. In addition, despite recent advancements in toxicological research in the air pollution field, the relationship between biodiesel particle composition and associated health effects is still not completely understood.

Ethanol is another biofuel that is gaining increased national media and state regulatory attention. CARB has recently amended the reformulated gasoline regulation to further increase the ethanol content to 10% as a means to increase the amount of renewable fuels in the state. It is projected that the state's ethanol use will increase from 900 million gallons in 2007 to 1.5 billion gallons by 2012 as a result. As in the case of biodiesel, ethanol has demonstrated in various emission studies to reduce PM, CO and toxic emissions; however, the relationship between particle composition and associated health effects from the combustion of ethanol is not well understood either.

DME is another fuel which requires evaluation of in-use emissions, especially NOx, in light of Volvo's announcement in 2015 that they will commercialize class 8 trucks using DME in the near future. Furthermore, CARB recently proposed a regulation on the commercialization of alternative diesel fuels, including biodiesel and renewable diesel, while noting that biodiesel in older heavy-duty vehicles can increase NOx and the need for emerging alternative diesel fuels to have clear ground rules for commercialization. The impact of natural gas fuel composition on emissions from heavy-duty trucks and transit buses is also being studied.

In order to address these concerns on potential health effects associated with biofuels, namely biodiesel and ethanol blends, this project will investigate the physical and chemical composition and associated health effects of tailpipe PM emissions from light- to heavy-duty vehicles burning biofuels in order to ensure public health is not adversely impacted by broader use of these fuels. This project also supports future studies to identify mitigation measures to reduce NOx emissions for biofuels. Additionally, a study of emissions from well-to-wheel for the extraction and use of shale gas might be considered.

Potential Air Quality Benefits:

If biodiesel and biodiesel blends can be demonstrated to reduce air pollutant emissions with the ability to mitigate any NOx impact, this technology will become a viable strategy to assist in meeting air pollutant standards as well as the goals of AB 32 and the Low-Carbon Fuel Standard. The use of biodiesel is an important effort for a sustainable energy future. Emission studies are critical to understanding the emission benefits and any tradeoffs (NOx impact) that may result from using this alternative fuel. With reliable information on the emissions from using biodiesel and biodiesel blends, the SCAQMD can take actions to ensure the use of biodiesel will obtain air pollutant reductions without creating additional NOx emissions that may exacerbate the Basin's ozone problem.

Proposed Project: Identify and Demonstrate In-Use Fleet Emissions Reduction Technologies and Opportunities

Expected SCAQMD Cost: \$250,000

Expected Total Cost: \$2,000,000

Description of Technology and Application:

New technologies, such as alternative fueled heavy-duty engines, are extremely effective at reducing emissions because they are designed to meet the most stringent emissions standards while maintaining vehicle performance. In addition, many new vehicles are now equipped with telematics enabling motorists to obtain transportation information such as road conditions to avoid excessive idling and track information about the vehicle maintenance needs, repair history, tire pressure and fuel economy. Telematics have been shown to reduce emissions from new vehicles. Unfortunately, the in-use fleet lacks telematic systems--particularly heavy-duty engines in trucks, buses, construction equipment, locomotives, marine vessels and cargo handling equipment--have fairly long working lifetimes (up to 20 years due to remanufacturing in some cases). Even light-duty vehicles routinely have lifetimes exceeding 200,000 miles and 10 years. And it is the in-use fleet, especially the oldest vehicles, which are responsible for the majority of emissions.

This project category is to investigate near-term emissions control technologies which can be economically applied to reduce emissions from the in-use fleet. The first part of the project is to identify and conduct proof-of-concept demonstrations of feasible candidate technologies, such as:

- remote sensing for heavy-duty vehicles;
- annual testing for high mileage vehicles (>100,000 miles);
- replace or upgrade emissions control systems at 100,000 mile intervals;
- on-board emission diagnostics with remote notification;
- low-cost test equipment for monitoring and identifying high emitters;
- test cycle development for different class vehicles (e.g. four wheel drive SUVs);
- electrical auxiliary power unit replacements; and
- development, deployment and demonstration of smart vehicle telematic systems

Potential Air Quality Benefits:

Many of the technologies identified can be applied to light-duty and heavy-duty vehicles to identify and subsequently remedy high-emitting vehicles in the current fleet inventory. Estimates suggest that 5 percent of existing fleets account for up to 80 percent of the emissions. Identification of higher emitting vehicles would assist with demand-side strategies, where higher emitting vehicles have correspondingly higher registration charges.

Stationary Clean Fuel Technologies

Proposed Project: Develop and Demonstrate Reliable, Advanced Emission Control Technologies, and Low-Emission Monitoring Systems and Test Methods

Expected SCAQMD Cost: \$150,000

Expected Total Cost: \$500,000

Description of Technology and Application:

Currently, the inability of air/fuel ratio control (AFRC) systems to keep rich-burn engines in compliance contributes significantly to air pollution in the basin. Reliable, low-cost emission monitoring systems are needed for small-to-intermediate size combustion devices, including stationary engines, boilers, heaters, furnaces and ovens that are not large enough to justify a continuous emission monitoring system (CEMS). This class of combustion device is often permitted on the basis of a single demonstration or periodic demonstrations of NO_x and CO emissions meeting SCAQMD rule requirements or a RECLAIM concentration limit. However, SCAQMD-unannounced tests on engines and boilers have found that in many cases NO_x and/or CO levels have increased significantly above levels that have been initially or periodically demonstrated due to equipment malfunction and/or inadequate operator attention. It is suspected that the same may be true of heaters, furnaces and ovens.

A recent demonstration project funded in part by the SCAQMD consisted of retrofitting a biogas engine with a digester gas clean up system and catalytic oxidizer at the exhaust followed by SCR which resulted in significant reductions of NO_x, VOC and CO. Based on the successful deployment of this project, further emission reductions may be achieved by other biogas combustion sources such as gas turbines and boilers by the continued development of specialized low cost biogas clean up systems that will allow for the use of catalytic after control systems.

Demonstrations of newer technologies in recent years could result in a commercially viable alternative to CEMS that is both reliable and feasible in terms of lower costs. For example, manufacturers of flue gas analyzers have, in recent years, developed low-cost multi-gas analyzers suitable for portable or stack-mounted use. Some preliminary testing of a new type of AFRC, which uses a different type of O₂ sensor known as a wide-band O₂ sensor, is another alternative that can be analyzed. Another technical approach might be to deploy technology utilizing the O₂ signature of a post-catalyst O₂ sensor and additional control concepts being developed by manufacturers. Since an underlying problem has been that engine, catalyst and AFRC manufacturers have developed systems independently, a system being co-developed to perform continuous diagnostics to assist operators in keeping rich-burn engines in compliance is possibly another alternative for demonstration.

Potential Air Quality Benefits:

Stationary engines, boilers, heaters, furnaces and ovens account for approximately 11 percent of total NO_x emissions and about 6 percent of total CO emissions. There has been a long-standing compliance problem with rich-burn IC engines in the basin and evidence indicates that many of these devices are operating with NO_x and/or CO emissions above levels required in their permits. Projects could potentially reduce a significant class of NO_x and CO emissions that are in excess of the assumptions in the AQMP and further enhance SCAQMD's ability to enforce full-time compliance.

Proposed Project: Develop and Demonstrate Clean Stationary Technologies

Expected SCAQMD Cost: \$250,000

Expected Total Cost: \$750,000

Description of Technology and Application:

Stationary sources, including VOC sources such as large printing facilities and furniture manufacturers, have become cleaner and cleaner due to the regulatory requirements for low emissions and the advancements in technology to meet those requirements. Best Available Control Technology (BACT) regulations, however, are only required for new, modified, or relocated sources. This project category is to develop and demonstrate new technologies that can provide emissions reductions in new installations or as retrofit modifications. Possible technology examples include:

- low NO_x technologies (burners and ICEs);
- low-Btu gas technologies (e.g., digester, landfill, or dairy gases);
- alternative fuels and hydrogen blends;
- alternative diesel fuels (emulsified, gas-to-liquids, biodiesel with aftertreatment);
- low emission refinery flares;
- catalytic combustion;
- cost-effective fuel cell and fuel cell hybrid distributed generation;
- fumes-to-fuel technology to replace thermal oxidizers and capture VOC emissions for electricity generation while ensuring no emission of air toxics; and
- boiler optimization design and strategies to improve efficiencies.

Depending on the technology, a proof-of-concept project, demonstration, or pre-commercial deployment would be considered to garner further information on the technology. Issues to investigate include viability (reliability, maintainability and durability) of the technology, cost-effectiveness and operator ease-of-use in order to assess commercialization.

Potential Air Quality Benefits:

The SCAQMD has a substantial number of older, small, stationary source technologies within its jurisdiction. Since these devices are not subject to continuous emissions monitoring system requirements, evidence suggests that these devices may not be operating at their permitted NO_x, CO, hydrocarbon and PM emissions levels. Replacing these devices with cleaner and more reliable technologies or technology/fuel combinations can have dramatic reductions in all of these criteria pollutants. VOC emission reductions may also be achieved at larger stationary VOC sources to achieve the new federal ozone and PM_{2.5} standards.

Proposed Project: Develop and Demonstrate Renewables-Based Energy Generation Alternatives

Expected SCAQMD Cost: \$200,000

Expected Total Cost: \$1,000,000

Description of Technology and Application:

The objective of this proposed project is to support the development and demonstration of clean energy, renewable alternatives in stationary and mobile applications. The technologies to be considered include thermal, photovoltaic and other solar energy technologies; wind energy systems; energy storage and conservation potentially including vehicle to grid or vehicle to building functionalities for alternative energy storage; biomass conversion; and other renewable energy and recycling technologies. Innovative solar technologies, such as solar thermal air conditioning and photovoltaic-integrated roof shingles, are of particular interest. Also, in the agricultural sections of the Basin, wind technologies could potentially be applied to drive large electric motor-driven pumps to replace highly polluting diesel-fired pumps. Besides renewable technologies, electrolyzer technology could be used to generate hydrogen, a clean fuel. Hydrogen, when used in regular engines, can substantially reduce tail-pipe emissions, while in fuel cells the emissions are reduced to zero.

The project is expected to result in pilot-scale production demonstrations, scale-up process design and cost analysis, overall environmental impact analysis and projections for ultimate clean fuel costs and availability. This project is expected to result in several projects addressing technological advancements in these technologies that may improve performance and efficiency, potentially reduce capital and operating costs, enhance the quality of natural gas generated from renewable sources for injection into natural gas pipelines, improve reliability and user friendliness and identify markets that could expedite the implementation of successful technologies.

Potential Air Quality Benefits:

The Draft 2016 AQMP identifies the development and ultimately the implementation of non-polluting power generation. To gain the maximum air quality benefit, polluting fossil fuel-fired electric power generation needs to be replaced with clean renewable energy resources or other advanced zero emission technologies, such as hydrogen fuel cells, particularly in a distributed generation context.

The proposed project is expected to accelerate the implementation of advanced zero emission energy sources. Expected benefits include directly reducing the emissions by the displacement of fossil generation; proof-of-concept and potential viability for such zero emission power generation systems; increased exposure and user acceptance of the new technology; reduced fossil fuel usage; and the potential for increased use, once successfully demonstrated, with resulting emission benefits, through expedited implementation. These technologies would also have a substantial influence in reducing global warming emissions.

Emission Control Technologies

Proposed Project: Develop and Demonstrate Advanced Aftertreatment Technologies

Expected SCAQMD Cost: \$300,000

Expected Total Cost: \$5,000,000

Description of Technology and Application:

There are a number of aftertreatment technologies which have shown substantial emission reductions in diesel engines. These technologies include diesel particulate filters (DPFs), oxidation catalysts, selective catalytic reduction (SCR) systems and NO_x adsorbers. This project category is to develop and demonstrate these aftertreatment technologies alone or in tandem with an alternative fuel to produce the lowest possible PM, ultrafine particles, nanoparticles, NO_x, CO, carbonyl and hydrocarbon emissions in retrofit and new applications. With the increasing focus on zero- and near-zero emission goods movement technologies, this category should examine idle reduction concepts and technologies that can be employed at ports and airports.

Possible projects include advancing the technologies for on-road retrofit applications such as heavy-duty line-haul diesel engines, street sweepers, waste haulers and transit buses. Applications for non-road may include construction equipment, yard hostlers, gantry cranes, locomotives, marine vessels, ground support equipment and other similar industrial applications. Potential fuels to be considered in tandem are low-sulfur diesel, emulsified diesel, biodiesel, gas-to-liquids, hydrogen and natural gas. This project category will also explore the performance, economic feasibility, viability (reliability, maintainability and durability) and ease-of-use to ensure a pathway to commercialization.

Potential Air Quality Benefits:

The transfer of mature emission control technologies, such as DPFs and oxidation catalysts, to the off-road sector is a potentially low-risk endeavor that can have immediate emissions reductions. Further development and demonstration of other technologies, such as SCR and NO_x adsorbers, could also have NO_x reductions of up to 90%.

Proposed Project: Demonstrate On-Road Technologies in Off-Road and Retrofit Applications

Expected SCAQMD Cost: \$200,000

Expected Total Cost: \$1,000,000

Description of Technology and Application:

Heavy-duty on-road engines have demonstrated progress in meeting increasingly stringent Federal and state requirements. New heavy-duty engines have progressed from 2 g/bhp-hr NO_x in 2004 to 0.2 g/bhp-hr NO_x in 2010, which is an order of magnitude decrease in just six years. Off-road engines, however, have considerably higher emissions limits depending on the engine size. For example, Tier-3 standards for heavy-duty engines require only 3 g/bhp-hr NO_x. There are apparent opportunities to implement cleaner on-road technologies in off-road applications. There is also an opportunity to replace existing engines in both on-road and off-road applications with the cleanest available technology. Current regulations require a repower (engine exchange) to only meet the same emissions standards as the engine being retired. Unfortunately, this does not take advantage of recently developed clean technologies.

Exhaust gas cleanup strategies, such as SCR, electrostatic precipitators, baghouses and scrubbers, have been used successfully for many years on stationary sources. The exhaust from the combustion source is routed to the cleaning technology, which typically requires a large footprint for implementation. This large footprint has made installation of such technologies on some mobile sources prohibitive. However, in cases where the mobile source is required to idle for long periods of time, it may be more effective to route the emissions from the mobile source to a stationary device to clean the exhaust stream.

Projects in this category will include utilizing proven clean technologies in novel applications, such as:

- demonstrating certified LNG and CNG on-road engines in off-road applications including yard hostlers, switcher locomotives, gantry cranes, waste haulers and construction equipment;
- implementing lower emission engines in repower applications for both on-road and off-road applications; and
- applying stationary best available control technologies, such as SCR, scrubbers, baghouses and electrostatic precipitators, to appropriate on- and off-road applications, such as idling locomotives, marine vessels at dock and heavy-duty line-haul trucks at weigh stations.

Potential Air Quality Benefits:

The transfer of mature emission control technologies, such as certified engines and SCR, to the non-road and retrofit sectors offers high potential for immediate emissions reductions. Further development and demonstration of these technologies will assist in the regulatory efforts which could require such technologies and retrofits.

Health Impacts Studies

Proposed Project: Evaluate Ultrafine Particle Health Effects

Expected SCAQMD Cost: \$150,000

Expected Total Cost: \$2,000,000

Description of Technology and Application:

Reducing diesel exhaust from vehicles has become a high priority in the South Coast Air Basin since CARB identified the particulate phase of diesel exhaust as a surrogate for all of the toxic air contaminant emitted from diesel exhaust. Additionally, health studies indicate that the ultrafine portion of particulate matter may be more toxic on a per-mass basis than other fractions. Several technologies have been introduced and others are under development to reduce diesel emissions. These include among others low-sulfur diesel fuel, particulate matter traps and heavy-duty engines operating on alternative fuel such as CNG and LNG. Recent studies have shown that control technologies applied to mobile sources have been effective in reducing the mass of particulates emitted. However, there is also evidence that the number of ultrafine particles on and near roadways has increased, even while the mass of particulates has decreased. To have a better understanding of changes in ultrafine particulate emissions from the application of the new technologies and the health effects of these emissions, an evaluation and comparison of ultrafine particulate matter and the potential impacts on community exposures are necessary.

In this project, measurements and chemical composition of ultrafine particulates will be done, as well as studies conducted to characterize their toxicity. The composition of the particulates can further be used to determine the contribution from specific combustion sources. Additionally, engine or chassis dynamometer testing may be conducted on heavy-duty vehicles to measure, evaluate and compare ultrafine particulate matter, PAH and other relevant toxic emissions from different types of fuels such as CNG, low-sulfur diesel, biofuels and others. This project needs to be closely coordinated with the development of technologies for alternative fuels, aftertreatment and new engines in order to determine the health benefits of such technologies.

Furthermore, gasoline direct injection (GDI) vehicles are known for higher efficiency and power output but the PM emissions profile is not well understood especially on secondary organic aerosol (SOA) formation potential. As manufacturers introduce more GDI models in the market to meet new fuel economy standards, it is important to understand the SOA potential from these vehicles as it could lead to further impact on the ambient PM concentration in our region. Consequently, in 2015 a project was initiated with UCR/CE-CERT to investigate the physical and chemical composition of aerosols from GDI vehicles using a mobile environmental chamber that has been designed and constructed to characterize secondary emissions. Based on this initial results indicating an increase in particle numbers, follow-up in-use studies to assess PM emissions including with and without particle filters will be beneficial.

Potential Air Quality Benefits:

The AQMP for the South Coast Basin relies on significant penetration of low emission vehicles to attain federal clean air standards. Reduction of particulate emissions from the combustion of diesel and other fuels is a major priority in achieving these standards. This project would help to better understand the nature and amount of ultrafine particulates generated by different types of fuels and advanced control technologies as well as provide information on potential health effects of ultrafine particles. Such an understanding is important to assess the emission reduction potentials and health benefits of these technologies. In turn, this will have a direct effect on the policy and regulatory actions for commercial implementation of alternative fuel vehicles in the Basin.

Proposed Project: Conduct Monitoring to Assess Environmental Impacts

Expected SCAQMD Cost: \$150,000

Expected Total Cost: \$500,000

Description of Technology and Application:

Facilities, buildings, structures, or highways which attract mobile sources of pollution are considered “indirect” sources. Ambient and saturation air monitoring near sources such as ports, airports, rail yards, distribution centers and freeways is important to identify the emissions exposure to the surrounding communities and provide the data to then conduct the health impacts due to these sources. This project category would identify areas of interest and conduct ambient air monitoring, conduct emissions monitoring, analyze the data and assess the potential health impacts from mobile sources. The projects would need to be at least one year in duration in order to properly assess the air quality impacts in the area.

Potential Air Quality Benefits:

The proposed project will assist in the evaluation of adverse public health impacts associated with mobile sources. The information will be useful in (a) determining whether indirect sources have a relatively higher impact on residents living in close proximity; and (b) providing guidance to develop some area-specific control strategies in the future should it be necessary.

Proposed Project: Assess Sources and Health Impacts of Particulate Matter

Expected SCAQMD Cost: \$150,000

Expected Total Cost: \$300,000

Description of Technology and Application:

Previous studies of ambient levels of toxic air contaminants, such as the MATES series of studies, have found that diesel exhaust is the major contributor to health risk from air toxics. Analyses of diesel particulate matter in ambient samples have been based on measurements of elemental carbon. While the bulk of particulate elemental carbon in the South Coast Air Basin is thought to be from combustion of diesel fuels, it is not a unique tracer for diesel exhaust.

The MATES III study collected particulate samples at ten locations in the South Coast Air Basin. Analysis of particulate bound organic compounds was utilized as tracers to estimate levels of ambient diesel particulate matter as well as estimate levels of particulate matter from other major sources. Other major sources that were taken into consideration include automobile exhaust, meat charbroiling, road dust, wood smoke and fuel oil combustion. Analyzing for organic compounds and metals in conjunction with elemental carbon upon collected particulate samples was used to determine contributing sources.

MATES IV, initiated in mid-2012, included an air monitoring program, an updated emissions inventory of toxic air contaminants and a regional modeling effort to characterize risk across the Basin. In addition to air toxics, MATES IV also measured ultrafine particle concentrations and black carbon at the monitoring sites as well as near sources such as airports, freeways, rail yards, busy intersections and warehouse operations.

This project category would include other related factors, such as toxicity assessment based on age, source (heavy-duty, light-duty engines) and composition (semi-volatile or non-volatile fractions) to better understand the health effects and potential community exposures. Additionally, early identification of new health issues could be of considerable value and could be undertaken in this project category.

Potential Air Quality Benefits:

Results of this work will provide a more robust, scientifically sound estimate of ambient levels of diesel particulate matter as well as levels of particulate matter from other significant combustion sources, including gasoline and diesel generated VOCs. This will allow a better estimation of potential exposures to and health effects from toxic air contaminants from diesel exhaust in the South Coast Air Basin. This information in turn can be used to determine the health benefits of promoting clean fuel technologies.

Technology Assessment/Transfer & Outreach

Proposed Project: Assess and Support Advanced Technologies and Disseminate Information

Expected SCAQMD Cost: \$425,000

Expected Total Cost: \$800,000

Description of Project:

This project supports the assessment of clean fuels and advanced technologies, their progress towards commercialization and the dissemination of information on demonstrated technologies. The objective of this project is to expedite the transfer of technology developed as a result of Technology Advancement Office projects to the public domain, industry, regulatory agencies and the scientific community. This project is a fundamental element in the SCAQMD's outreach efforts to expedite the implementation of low emission and clean fuels technologies and to coordinate these activities with other organizations.

This project may include the following:

- technical review and assessment of technologies, projects and proposals;
- support for alternative fuel refueling and infrastructure;
- advanced technology curriculum development, mentoring and outreach to local schools;
- emissions studies and assessments of zero emission alternatives;
- advanced technology vehicle demonstrations;
- preparation of reports, presentations at conferences, improved public relations and public communications of successful demonstrations of clean technologies;
- participation in and coordination of workshops and various meetings;
- support for training programs related to fleet operation, maintenance and refueling of alternative fuel vehicles;
- publication of technical papers, reports and bulletins; and
- production and dissemination of information, including web sites.

These objectives will be achieved by consulting with industry, scientific, health, medical and regulatory experts and co-sponsoring related conferences and organizations, resulting in multiple contracts. In addition, an ongoing outreach campaign will be conducted to encourage decision-makers to voluntarily switch to alternatively fueled vehicles and train operators to purchase, operate and maintain these vehicles and associated infrastructure.

Potential Air Quality Benefits:

SCAQMD adopted fleet regulations requiring public and private fleets within the Basin to acquire alternatively fueled vehicles when making new purchases. Expected benefits of highlighting success stories in the use of advanced alternatively fueled vehicles could potentially expedite the acceptance and commercialization of advanced technologies by operators seeking to comply with the provisions of the recently adopted SCAQMD fleet rules. The resulting future emissions benefits will contribute to the goals of the AQMP.

Proposed Project: Support Implementation of Various Clean Fuels Vehicle Incentive Programs

Expected SCAQMD Cost: \$325,000

Expected Total Cost: \$400,000

Description of Project:

This project supports the implementation of zero emission vehicle incentive programs, the Carl Moyer incentives program and the school bus incentives program. Implementation support includes application approval, grant allocation, documentation to the CARB, verification of vehicle registration and other support as needed. Information dissemination is critical to successful implementation of a coordinated and comprehensive package of incentives. Outreach will be directed to vehicle dealers, individuals and fleets.

Potential Air Quality Benefits:

As described earlier, the SCAQMD will provide matching funds to implement several key incentives programs to reduce diesel emissions in the Basin. Furthermore, the SCAQMD recently adopted fleet regulations requiring public and private fleets within the Basin to acquire alternatively fueled vehicles when making new purchases. Expected benefits of highlighting zero emission vehicle incentives could potentially expedite the acceptance and commercialization of advanced technologies by operators seeking to comply with the provisions of the recently adopted SCAQMD fleet rules. The resulting future emissions benefits will contribute to the goals of the AQMP. The school bus program and the Carl Moyer incentives program will also reduce large amounts of NO_x and PM emissions in the basin in addition to reducing toxic air contaminants.

Appendix A
SCAQMD Advisory Groups

[This Page Intentionally Left Blank]

Technology Advancement Advisory Group

Dr. Matt Miyasato, Chair	SCAQMD
<i>Pending</i>	Non-Governmental Organization
Dr. Alberto Ayala.....	California Air Resources Board
<i>Pending</i>	U.S. Department of Energy
Dr. John Froines.....	Professor Emeritus University of California, Los Angeles
Gretchen Hardison	Los Angeles Department of Water and Power; Chair of Technical Advisory Committee of the Mobile Source Air Pollution Reduction Review Committee
*Dawn Wilson	Southern California Edison
*David Pettit	Natural Resources Defense Council
Randall Lewis	Lewis Group of Companies
Tim Olson	California Energy Commission
*Nick Economides	Western States Petroleum Association
Cherif Youssef	Southern California Gas Company

*Newly appointed members

SB 98 Clean Fuels Advisory Group

Dr. Matt Miyasato, Chair	SCAQMD
Robert Bienenfeld	American Honda Motor Company Inc
<i>Pending</i>	Independent Consultant in Combustion Technology
Dr. Mridul Gautam.....	West Virginia University, Adjunct Professor, & University of Nevada-Reno
Dr. Fritz Kalhammer	Independent Consultant in Energy and Process Technology
*John Faust	California Environmental Protection Agency, Office of Environmental Health Hazard Assessment
Dr. Wayne Miller	University of California, Riverside, College of Engineering, Center for Environmental Research and Technology
Dr. Vernon Roan.....	University of Florida, Professor Emeritus
Dr. Scott Samuelson.....	University of California, Irvine, Combustion Laboratory/National Fuel Cell Research Center
Dr. Robert Sawyer	Sawyer Associates
Kevin Walkowicz.....	National Renewable Energy Laboratory
<i>Pending</i>	Independent Consultant in Fuel Cell Technologies
Michael Walsh	Independent Consultant in Motor Vehicle Pollution Control

*Newly appointed members

Appendix B

Open Clean Fuels Contracts as of January 1, 2017

[This Page Intentionally Left Blank]

Contract	Contractor	Project Title	Start Term	End Term	SCAQMD \$	Project Total \$
Hydrogen and Mobile Fuel Cell Technologies and Infrastructure						
10482	California State University Los Angeles	Install and Demonstrate PEM Electrolyzer, Providing Hydrogen Fueling for Vehicles and Utilizing the Technology in the Engineering Technology Curriculum at the University	03/04/11	10/03/17	250,000	1,662,000
11555	University of California Los Angeles	Construct Hydrogen Fueling Infrastructure	12/07/12	12/31/19	400,000	2,589,990
12057	Linde, LLC	Expand Hydrogen Fueling Infrastructure	11/02/12	04/01/19	80,000	160,000
13155	Fletcher Jones Motor Cars (Mercedes-Benz)	Lease Two F-Cell Fuel Cell Vehicles for Two Years	02/08/13	02/08/17	44,995	44,995
14139	Hyundai America Technical Center Inc.	No-Cost Lease of Fuel Cell Vehicle for Two Years	12/13/13	12/31/17	0	0
14684	California Department of Food and Agriculture, Division of Measurement Standards	Conduct Hydrogen Station Site Evaluations for Site Certifications for Commercial Sale of Hydrogen	12/11/15	08/31/17	100,000	100,000
15150	Air Products and Chemicals Inc.	Install and Upgrade Eight Hydrogen Fueling Stations Throughout SCAB (including SCAQMD's Diamond Bar Hydrogen Station)	10/10/14	04/09/19	1,000,000	17,335,439
15366	EPC LLC	Operate and Maintain Publicly Accessible Hydrogen Fueling Station at SCAQMD's Headquarters	10/10/14	09/14/17	0	0
15609	ITM Power, Inc.	Installation of Riverside Renewable Hydrogen Fueling Station	10/06/15	10/05/19	200,000	2,325,000
15611	Ontario CNG Station, Inc.	Installation of Ontario Renewable Hydrogen Fueling Station	07/10/15	07/09/20	200,000	2,325,000
15618	FirstElement Fuel, Inc.	Installation of Eight Hydrogen Stations in Various Cities (two renewable, six delivered)	02/05/16	02/04/21	1,000,000	16,442,000
15619	H2 Frontier Inc.	Installation of Chino Renewable Hydrogen Station	12/04/15	12/03/20	200,000	4,558,274
15635	Center for Transportation and Environment	ZECT II: Develop and Demonstrate One Class 8 Fuel Cell Range-Extended Electric Drayage Truck	04/27/16	10/26/20	821,198	7,109,384
15641	Hardin Hyundai	Three-Year Lease of 2015 Tucson Fuel Cell Vehicle	06/15/15	06/14/18	22,862	22,862
16025	Center for Transportation and Environment	Develop and Demonstrate Fuel Cell Hybrid Electric Medium-Duty Trucks	02/05/16	08/04/20	980,000	7,014,000
16039	Lawrence Livermore National Laboratory	Demonstrate Prototype Hydrogen Sensor and Electronics Package	12/10/15	02/09/17	175,000	350,000
16171	Longo Toyota	Three-Year Lease of 2015 Toyota Mirai Fuel Cell Vehicle	12/15/15	12/14/18	24,567	24,567
16251	H2 Frontier, Inc.	Develop and Demonstrate Commercial Mobile Hydrogen Fueler	05/06/16	05/05/21	200,000	1,665,654

Contract	Contractor	Project Title	Start Term	End Term	SCAQMD \$	Project Total \$
----------	------------	---------------	------------	----------	-----------	------------------

Hydrogen and Mobile Fuel Cell Technologies and Infrastructure (cont.)

17030	Bevilacqua-Knight, Inc.	Participate in California Fuel Cell Partnership for Calendar Year 2016 and Provide Support for Regional Coordinator	01/01/16	12/31/16	135,000	1,694,793
17059	Calstart Inc.	Develop and Demonstrate Fuel Cell Extended-Range Powertrain for Parcel Delivery Trucks	10/27/16	04/26/18	589,750	1,574,250

Electric/Hybrid Technologies and Infrastructure

08063	Quantum Fuel Systems Technologies Worldwide, Inc.	Develop & Demonstrate 20 Plug-In Hybrid Electric Vehicles	01/22/08	01/31/18	2,165,613	2,899,057
12028	Electric Vehicle International, Inc.	Demonstrate and Replace UPS Diesel Delivery Trucks with Zero-Emission Medium-Duty Trucks	09/09/11	09/08/17	1,400,000	4,872,000
13058	Capstone Turbine Corporation	Develop Microturbine Series Hybrid System for Class 7 Heavy-Duty Vehicle Applications	08/12/13	12/31/17	360,000	1,210,000
13396	Transportation Power Inc.	Develop and Demonstrate Seven Class 8 Zero Emission Electric Trucks	04/19/13	09/30/17	375,000	2,285,368
13426	Transportation Power, Inc.	Develop & Demonstrate Catenary Class 8 Trucks (1 Electric & 1 CNG Platform)	06/07/13	07/31/18	2,617,887	3,182,795
13433	U.S. Hybrid Corporation	Develop and Demonstrate Two Class 8 Zero-Emission Electric Trucks	06/26/13	09/30/17	75,000	150,000
13439	City of Carson	MOU for Catenary Zero Emission Goods Movement Project	10/01/13	07/31/18	0	0
14052	Altec Capital Services, LLC	Lease of Two Plug-In Hybrid Electric Vehicles	01/02/15	01/01/20	61,302	61,302
14062	Siemens Industry Inc.	Develop and Demonstrate Catenary Zero Emissions Goods Movement System and Develop and Demonstrate Diesel Catenary Hybrid Electric Trucks	07/14/14	07/13/18	5,500,000	14,780,000
14156	Galpin Motors Inc. (Galpin Ford)	Lease of Two Fusion Energi and One C-Max Energi PHEVs for a Three-Year Period	01/28/14	01/27/17	49,298	49,298
14184	Clean Fuel Connection Inc.	DC Fast Charging Network Provider	04/04/14	06/30/20	920,000	1,220,000
14222	Odyne Systems, LLC	Develop and Demonstrate Plug-In Hybrid Electric Retrofit System for Class 6 to 78 Trucks	04/24/14	05/31/17	389,000	2,226,571
14224	Complete Coach Works	Develop and Test Retrofit All Electric Transit Bus	04/24/14	02/28/17	395,000	867,182
14256	National Strategies LLC	Develop and Demonstrate Vehicle-2-Grid Technology	09/05/14	03/04/18	250,000	3,377,689
14323	Selman Chevrolet Company	Lease Two 2014 Chevrolet Volt Extended-Range Electric Vehicles for Three Years	03/28/14	03/27/17	30,932	30,932
15382	ChargePoint, Inc.	Install Electric Charging Infrastructure	01/23/15	01/22/17	162,000	162,000

Contract	Contractor	Project Title	Start Term	End Term	SCAQMD \$	Project Total \$
----------	------------	---------------	------------	----------	-----------	------------------

Electric/Hybrid Technologies and Infrastructure (cont.)

15448	University of California Los Angeles	Site Selection for DC Fast Charge Network	04/21/15	04/30/17	10,000	10,000
15650	University of California San Diego	Develop and Demonstrate Solar Forecasting for Larger Solar Arrays with Storage and EV Charging	07/17/15	01/16/18	98,908	1,655,278
15680	National Renewable Energy Laboratory	ComZEV – Develop Detailed Technology and Economics-Based Assessment for Heavy-Duty Advanced Technology Development	08/28/15	04/14/17	500,000	500,000
16022	Gas Technology Institute	ZECT II: Develop and Demonstrate One Class 8 CNG Hybrid Electric Drayage Truck	12/04/15	06/30/20	1,578,802	5,627,319
16046	Transportation Power, Inc.	ZECT: Develop and Demonstrate Two Class 8 CNG Plug-In Hybrid Electric Drayage Trucks	12/04/15	09/30/17	195,326	2,103,446
16047	U.S. Hybrid Corporation	ZECT: Develop and Demonstrate Three Class 8 LNG Plug-In Hybrid Electric Drayage Trucks	11/06/15	09/30/17	22,896	1,996,675
16081	Broadband TelCom Power, Inc.	Provide EV Hardware and Control System at SCAQMD Headquarters including Installation Support, Warranty and Networking	04/27/16	04/26/22	367,425	367,425
16200	California State University Los Angeles	Cost-Share Regional Universities for U.S. DOE EcoCAR 3 Competition	04/14/16	04/15/20	100,000	300,000
16227	Selman Chevrolet Company	Lease One 2016 Chevrolet Volt Extended-Range Electric Vehicle for Three Years	02/01/16	01/31/19	15,677	15,677
17065	Clean Fuel Connection, Inc.	EV Infrastructure Installer	12/02/16	12/31/21	805,219	805,219

Engine Systems

15626	Cummins Westport, Inc.	Develop, Integrate and Demonstrate Ultra Low-Emission Natural Gas Engines for On-Road Heavy-Duty Vehicles	07/10/15	07/30/17	3,500,000	7,233,000
15632	Gas Technology Institute	Develop Ultra Low-Emission Natural Gas Engine for On-Road Medium-Duty Vehicles	09/01/15	06/30/17	750,000	1,800,0000
16205	Cummins Westport, Inc.	Develop, Integrate and Demonstrate Ultra-Low Emission 12-Liter Natural Gas Engines for On-Road Heavy-Duty Vehicles	06/03/16	06/30/18	2,750,000	6,307,000

Fueling Infrastructure and Deployment (NG/RNG)

07246	USA Waste of California, Inc., dba L.A. Metro	Purchase & Install New LNG Storage Tank at Long Beach LNG Refueling Station	12/24/08	06/30/17	200,000	440,000
08098	Redlands Unified School District	Purchase & Install New CNG Refueling Station	01/25/08	12/31/17	525,000	700,000
09364	Rim of the World Unified School District	Construct & Install a CNG Fueling Station	12/30/10	10/31/18	257,000	425,000

Contract	Contractor	Project Title	Start Term	End Term	SCAQMD \$	Project Total \$
Fueling Infrastructure and Deployment (NG/RNG) (cont.)						
12135	Placentia-Yorba Linda Unified School District	Upgrade CNG Fueling Station	11/18/11	11/30/17	60,000	60,000
12667	West Covina Unified School District	Upgrade CNG Fueling Facility	10/12/12	12/31/17	60,000	60,000
12851	Clean Energy	Install, Operate and Maintain Three LNG Fueling Stations (Fontana, Coachella and Perris)	10/05/12	12/31/18	1,400,000	4,277,323
12852	City of Covina	Construct Public Access CNG Fueling Stations	10/12/12	12/31/18	200,000	618,429
12853	Rainbow Disposal Co. Inc.	Upgrade CNG Fueling Station	03/08/13	12/31/18	200,000	400,000
12854	Waste Management, Inc.	Upgrade LNG Fueling Station at Baldwin Park Facility	08/17/12	12/31/18	300,000	1,588,100
14219	City of West Covina	Upgrade CNG Station at City Yard	05/15/14	06/15/17	200,000	618,429
14311	Southern California Gas Company	Install and Maintain CNG Fueling Station in Murrieta for SoCalGas	07/11/14	12/31/17	217,000	1,385,000
15438	United Parcel Service, Inc.	Refurbish/Upgrade Ontario UPS LCNG Infrastructure	12/31/14	06/30/18	246,707	484,535
16075	City of Desert Hot Springs	Purchase One Heavy-Duty CNG-Powered Truck	03/11/16	03/10/20	38,000	63,000
16076	Coachella Valley Association of Governments	Purchase and Deploy One Heavy-Duty CNG Paratransit Vehicle	12/01/15	11/20/19	140,000	140,000
16244	CR&R, Inc.	Renewable Natural Gas Production and Vehicle Demonstration Project	09/03/16	03/02/20	900,000	55,000,000
16333	Ontario CNG Station, Inc.	Implement Alternative Fuel Station Expansion	05/13/16	11/12/19	200,000	798,535
17092	Kore Infrastructure, LLC	Construct RNG Production Facility and Demonstrate RNG with Next Generation Natural Gas Engine	10/14/16	10/13/21	2,500,000	25,500,000

Fuels/Emission Studies

10722	University of California Riverside/CE-CERT	Re-Establish Testing Facility & Quantify PM Emission Reductions from Charbroiling Operations	08/06/10	06/30/17	60,000	321,700
14162	National Renewable Energy Laboratory	Utilization of Fleet DNA Approach and Capabilities to Provide Vehicle Vocational Analysis in SCAQMD	02/26/14	06/30/17	174,985	199,985
15607	University of California Riverside/CE-CERT	Innovative Transportation System Solutions for NOx Reductions in Heavy-Duty Fleets	12/19/15	05/30/17	79,980	139,980
15623	University of California Riverside/CE-CERT	Ozone and SOA Formation from Gasoline and Diesel Compounds	10/02/15	03/31/17	75,000	480,338
15625	University of California Riverside/CE-CERT	Evaluate SOA Formation Potential from Light-Duty GDI Vehicles	10/02/15	06/30/17	149,972	224,972
15636	University of California Riverside/CE-CERT	Evaluate PEV Utilization Through Advanced Charging Strategies in a Smart Grid System	12/15/15	08/31/17	170,000	270,000

Contract	Contractor	Project Title	Start Term	End Term	SCAQMD \$	Project Total \$
----------	------------	---------------	------------	----------	-----------	------------------

Fuels/Emission Studies (cont.)

16198	Gladstein, Neandross & Associates, LLC	Study of Opportunities and Benefits of Deploying Next Generation Heavy-Duty Natural Gas Vehicles Operating on Renewable Natural Gas	09/02/16	09/02/16	50,000	250,000
16254	University of California Berkeley	Evaluate Ozone and Secondary Aerosol Formation from Diesel Fuels	10/25/16	08/31/17	106,361	106,361
17060	University of California Riverside	Bailment Agreement for Equipment Use for In-Use Emissions Testing of Heavy-Duty Inspection and Maintenance Program	10/13/16	10/12/18	0	0

Stationary Clean Fuels Technology

13045	ClearEdge (novated from UTC Power Corp.)	Energy Supply and Services Agreement to Install One 400 kW Phosphoric Acid Fuel Cell at SCAQMD Headquarters	09/28/12	09/27/22	450,000	4,252,680
13408	University of California Irvine	Demonstrate Building Integration of Electric Vehicles, Photovoltaics and Stationary Fuel Cells	09/30/13	09/01/17	150,000	270,000

Health Impacts Studies

14171	Southern California Research Center/Allergy & Asthma Associates of Southern California	Risk of Incident Asthma Among Children from In-Utero Exposures to Traffic Related Pollutants	09/22/14	03/21/16	99,670	317,119
-------	--	--	----------	----------	--------	---------

Technology Assessment/Transfer & Outreach

05128	Mid-Atlantic Research Institute LLC	Development, Outreach and Commercialization of Advanced Heavy-Duty and Off-Road Technologies	08/08/05	03/31/17	70,000	70,000
08210	Sawyer Associates	Technical Assistance on Mobile Source Control Measures and Future Consultation on TAO Activities	02/22/08	02/28/18	10,000	10,000
09252	JWM Consulting Services	Technical Assistance with Review and Assessment of Advanced Technologies, Heavy-Duty Engines, and Conventional and Alternative Fuels	12/20/08	06/30/18	30,000	30,000
12376	University of California Riverside	Technical Assistance with Alternative Fuels, Biofuels, Emissions Testing and Zero-Emission Transportation Technology	06/13/14	05/31/18	75,000	75,000
12381	Integra Environmental Consulting Inc.	Technical Assistance Related to Emission Inventories, Goods Movement and Off-Road Sources	04/06/12	04/30/18	110,000	110,000

Contract	Contractor	Project Title	Start Term	End Term	SCAQMD \$	Project Total \$
Technology Assessment/Transfer & Outreach (cont.)						
12453	Tech Compass	Technical Assistance with Alternative Fuels, Fuel Cells, Emissions Analysis and Aftertreatment Technologies	06/21/12	05/30/18	75,000	75,000
13194	Clean Fuel Connection Inc.	Technical Assistance with Alternative Fuels, Renewable Energy and Electric Vehicles	12/07/12	03/31/17	140,000	140,000
14185	Three Squares Inc.	Conduct Education Outreach for the Basin DC Fast Charging Network Project	04/11/15	04/30/17	89,183	89,183
15369	Breakthrough Technologies Institute, Inc.	Technical Assistance with Low- and Zero-Emission Vehicles, Fuel Cells, Stationary Applications and Emissions Analysis	11/07/14	12/31/17	30,000	30,000
15380	ICF Resources LLC	Technical Assistance with Goods Movement, Alternative Fuels and Zero-Emission Transportation Technologies	12/12/14	12/11/18	30,000	30,000
15507	Jerald Cole	Technical Assistance with Alternative Fuels, Emissions Analysis, and Combustion Technologies	01/09/15	01/08/17	30,000	30,000
15516	Cordoba Corporation	Technical Assistance with Construction of Zero Emissions Goods Movement Demonstration Project	03/27/15	03/31/18	74,500	74,500
15610	Goss Engineering, Inc.	Conduct Engineering Services at SCAQMD Headquarters	06/02/15	12/31/17	50,000	50,000
17037	Clean Fuel Connection, Inc.	Technical Assistance with Alternative Fuels, Electric Vehicles, Charging and Fueling Infrastructure and Renewable Energy	11/18/16	11/17/18	50,000	50,000
17097	Gladstein, Neandross & Associates, LLC	Technical Assistance with Alternative Fuels and Fueling Infrastructure, Emissions Analysis and On-Road Sources	11/04/16	11/03/18	100,000	100,000

Appendix C

Final Reports for 2016

[This Page Intentionally Left Blank]

Operation & Maintenance of City of Burbank Hydrogen Fueling Station

Contractor

Hydrogen Frontier, Inc.

Cosponsors

California Energy Commission (CEC)
California Air Resources Board (CARB)
U. S. Department of Energy (DOE)
SCAQMD

Project Officer

Larry Watkins/Lisa Mirisola

Background

The City of Burbank has hosted a hydrogen fueling station since 2006, starting with hydrogen generated by electrolysis as part of the Five Cities Hydrogen Demonstration Program under Contract #05165 with Air Products and Chemicals, Inc. This onsite reformer station was built in 2009 by BP, with funding and support provided by U.S. DOE and GM.

Project Objective

In 2010, the project plan was to provide hydrogen to the Burbank station via a tube trailer that would off-load into existing storage containers, and the steam methane reformer would be restored for use when fueling demand increased. SCAQMD approved a contract with Hydrogen Frontier, Inc. to repair unsafe or inoperable equipment, and for restarting, operation and maintenance, training of staff in use of equipment and procedures, and providing detailed vehicle fueling reports. Funds for utilities were not included in the budget.

Due to increased need for hydrogen fueling services, and in order to continue operation and maintenance and pay for the increase in utility services (electricity and natural gas) for the onsite reformer and station, an amendment to the contract with Hydrogen Frontiers, Inc., was required to add funding and expand the scope.

Technology Description

This hydrogen fueling facility consists primarily of a 108 kg/day steam methane reformer (SMR), 240 kg of ground storage at 430 bar, with vehicle

dispensing at both 350 & 700 bar refueling with associated supporting equipment.

This station is unique in its ability to use a compress-to-car top-off fueling profile, allowing more back-to-back fills without waiting for the station to replenish high pressure storage. As more zero emission cars are put on the road, it will be important to provide the customer a positive fueling experience.

Status

When Hydrogen Frontier took over the station from BP, it was a nonfunctioning 700 bar -20C and poor performing 350 bar delivery. With no support from prior companies, Hydrogen Frontier had to dissect all systems and review and rewrite operating codes for full functioning, achieving the best operating uptime of all stations in California for a period between 2011 & 2014. The SMR has nearly 19,000 runtime hours and still produces a kg of hydrogen for \$3.86. The station while almost ten years old is showing its age; maintenance schedules & mean time between failures are shorter. However, this location remains desirable and has proven a viable asset to the infrastructure network.



Figure 1: Burbank H2 Station

Results

This station recorded 11 consecutive back-to-back fills all to 98% SOC (state of charge). No other station to date has yet to meet or exceed this achievement.

During operation and maintenance it was imperative all data be collected to substantiate

performance and maintenance schedules for reliable uptime and cost forecasting. Hydrogen Frontier designed and implemented a comprehensive data collection system that could be accessible through any internet connection. All captured data was then able to be exported into NREL (National Renewable Energy Laboratory) format for ease of reporting.

Monitoring and recording over 152 different parameters allowed management and technicians to effectively and safely operate equipment remotely. This data allowed diagnosing potential failures before they happened and summon the proper experienced technician to respond. This reduced overall operating costs and the need to be onsite or travel to site to diagnose problems after events happened.

Measured performance was interesting compared to other stations. With the ability to produce hydrogen onsite even initially with a low throughput, emissions from delivered hydrogen operations were reduced. As the throughput increased, station efficiency increased and it became economically viable at 12 cars a day. The production of hydrogen was adjusted to 55 kg/day to meet actual dispensing demand.

Achieving operational efficiency with the highest uptime with the limited funds available in less than a year is a significant accomplishment.

While this station was a compress-to-car fueling profile, all automakers brought fuel cell vehicles to fill and were happy with its reliability and performance. There has been a movement to only favor SAE J2601-2014 cascade-fill profiles. This protocol is very conservative; one disadvantage is that “state of charge” (SOC) will drop as more cars are waiting in line for the station to replenish the cascade pressure. Total hydrogen produced over four years was 162,000 kilograms.

Benefits

The project benefits are directly reduced emissions, increased hydrogen production/dispensing, energy efficiency and reduced global warming gases. This project provided important lessons learned on station operation and maintenance, which can be applied to subsequent hydrogen stations.

Project Costs

Original project costs were \$1,060,000, as follows: U. S. DOE, \$360,000; CARB, \$300,000 (pass-through to SCAQMD); CEC, \$200,000; and SCAQMD \$200,000. However, SCAQMD

augmented this funding with an additional \$275,000 to continue station operation and maintenance through January 2016 under this contract.

The project costs were relatively low since all the major equipment was already paid for and this project mainly focused on evaluations of go or no-go decisions. All subsystems were evaluated for current operational status and then matrixes of additional elements were defined to ensure proper cost evaluations for operational status. Evaluation of critical spare components helped to achieve an operational goal of 99% uptime. These two models were used to reduce potential overspending for equipment that would not meet performance specifications. After initial funding sources were exhausted, additional funds were available to continue the operational and maintenance program based on past success.

Hydrogen cost at the dispenser was just under \$5/kg and sold for \$15/kg. With the small volume of cars during this period, actual costs varied by volume of throughput. Sometimes all the hydrogen produced was used, and at other times, only 20%. This made a baseline cost difficult to predict.

Commercialization and Applications

This type of operation and maintenance practice with this type of fill profile have provided valuable insights for the commercialization market. Energy efficiencies are better than conventional stations and back-to-back performance is virtually limited only by hydrogen production or delivery. Unfortunately, the SAE J2601 fueling profile will not be met 100% of the time without more funding for research and testing.

The station has become an important connector station for fuel cell vehicles in Southern California and provided up to 60 kg per day. Continued operation and maintenance of hydrogen fueling at this site helped bridge the gap in preparation for additional upgrade to provide retail sale of hydrogen for light-duty vehicles to be funded by a grant award under the CEC AB 118 program.

As the number of hydrogen vehicles on the road increases, different products with larger capacities, such as liquid hydrogen or pipeline supply and larger compressors, would need to be installed. Consideration should also be given to the use of renewable electricity generation, such as solar for the electrolyzers, due to the significant impact on operational costs and greenhouse gas emissions.

Participate in California Fuel Cell Partnership for CY 2016 & Provide Support for Regional Coordinator

Contractor

Bevilacqua-Knight, Inc. (BKl)

Cosponsors

7 Automakers
6 Public agencies
1 Technology provider
12 Associate members
14 Affiliate members

Project Officer

Lisa Mirisola

Background

Established with eight members in 1999, the California Fuel Cell Partnership (CaFCP) is a collaboration in which private and public entities are independent participants. It is not a joint venture, legal partnership or unincorporated association. Therefore, each participant contracts with Bevilacqua-Knight, Inc. (BKl) for their portion of CaFCP administration. SCAQMD joined the CaFCP in April 2000, and the CaFCP currently includes a total of 40 organizations interested in demonstrating fuel cell vehicle and fueling infrastructure technology.

Project Objectives

Several key goals for 2016:

- Develop the necessary infrastructure and processes to support early commercial launch and expanded vehicle rollout.
- Provide forums and opportunities for members to advance group collaboration and progress within CaFCP and among stakeholders.
- Reach target markets and communities to educate, inform and promote hydrogen and FCEVs.
- Restructure CaFCP to be more inclusive and capable of meeting the expanding commercial market needs and opportunities, broadening the member base, and being the voice of all stakeholder participants.

Status

The members of the CaFCP intend to continue their cooperative demonstration efforts and have set goals through 2016, subject to a budget approved annually. This final report covers the SCAQMD Contract #17030 for 2016

membership. This contract was completed on schedule.



Figure 1: CaFCP participated with SCAQMD in the annual Glendale Cruise Night in July, educating attendees about fuel cell vehicles, such as the Toyota Mirai.

Technology Description

The CaFCP members together or individually are demonstrating fuel cell passenger cars and transit buses and associated fueling infrastructure in California. The passenger cars include Daimler's B Class F-CELL, Honda's Clarity, Hyundai's Tucson, and Toyota's Mirai. The fuel cell transit buses include 13 placed at AC Transit (Van Hool buses with US Hybrid and Ballard fuel cells) and five placed at Sunline Transit (1 Ballard/New Flyer and 3 Ballard/BAE/EIDorado), one placed with Orange County Transportation Authority and one placed with UC Irvine Student Transportation..

Results

Specific accomplishments include:

- More than 1,000 consumers and fleets have purchased or leased FCEVs since FCEVs entered the commercial market in 2015;
- Transit agency members have demonstrated 28 fuel cell buses since 1999, with 20 currently in operation and more than 30 funded in 2016 (see Technology Description section);
- There are 25 retail and six other non-retail hydrogen fueling stations in operation in California and 26 in development.

- CaFCP staff and members continue to conduct outreach and education in communities throughout California;
- CaFCP, the Governor's Office of Business and Economic Development and the California Energy Commission, continue advising and responding to city staff across the state of California to optimize station permitting.
- CaFCP created and maintain the Station Operational Status System (SOSS) that more than 30 hydrogen stations in the U.S. use to report status to seven front-end systems.

Benefits

Compared to conventional vehicles, fuel cell vehicles can offer zero or near-zero smog-forming emissions, reduced water pollution from oil leaks, higher efficiency and much quieter and smoother operation. If alternative or renewable fuels are used as a source for hydrogen, fuel cell vehicles will also encourage greater energy diversity and lower greenhouse gas emissions (CO₂).

By combining efforts, the CaFCP can accelerate and improve the commercialization process. The members have a shared vision about the potential of fuel cells as a practical solution to many of California's environmental issues and similar issues around the world. The CaFCP provides a unique forum where technical and interface challenges can be identified early, discussed, and potentially resolved through cooperative efforts.

Project Costs

Auto members provide vehicles, and the staff and facilities to support them. Energy members engage in fueling infrastructure activities. The CaFCP's annual operating budget is about \$2 million, and includes facility operating costs, program administration, joint studies and public outreach and education. Each member makes an annual contribution of approximately \$85,000 towards the common budget. Some government agencies contribute additional in-kind products and services. SCAQMD provides an additional \$50,000 annually to support a Southern California Regional Coordinator and provides office space for additional staff in-kind at SCAQMD. SCAQMD's contribution for 2016 was \$134,800.

Commercialization and Applications

While research by multiple entities will be needed to reduce the cost of fuel cells and improve fuel

storage and infrastructure, the CaFCP can play a vital role in demonstrating fuel cell vehicle reliability and durability, fueling infrastructure and storage options and increasing public knowledge and acceptance of the vehicles and fueling.

From 2013 to 2016, CaFCP's goals relate to Preparing for Market Launch through coordinated individual and collective effort. During this fourth phase, CaFCP members, individually or in groups, will focus on the following important goals:

- Prepare for larger-scale manufacturing, which encompasses cost reduction, supply chain and production.
- Work on the customer channel, including identifying and training dealers and service technicians.
- Reduce costs of station equipment, increase supply of renewable hydrogen at lower cost, and develop new retail station approaches.
- Support cost reduction through incentives and targeted RD&D projects.
- Continue research, development and demonstration of advanced concepts in renewable and other low-carbon hydrogen.
- Provide education and outreach to the public and community stakeholders on the role of FCEVs and hydrogen in the evolution to electric drive.

In 2017, the primary goals are to:

- Decrease hydrogen station development time lines and costs
- Identify technology challenges and information gaps within the state's hydrogen station network
- Coordinate and collaborate on consensus approaches to achieving first 100 hydrogen stations in California
- Identify new concepts & approaches to initiate exponential station network growth
- Communicate progress of FCEVs and hydrogen to current and new stakeholder audiences.
- Facilitate implementation of two FCEB (Fuel Cell Electric Bus) Centers of Excellence (No. and So. Calif.)
- Increase awareness and market participation of fuel cell electric trucks, including supporting the deployment of funded pilot projects
- Coordinate nationally and internationally to share and align approaches

Extended Data Collection for Plug-In Hybrid Medium-Duty Truck Demonstration

Contractor

Electric Power Research Institute (EPRI)

Cosponsors

EPRI
SCAQMD

Project Officer

Joseph Impullitti

Background

This project was to perform extended data collection for a project, *Develop and Demonstrate a Fleet of Medium-Duty Plug-In Hybrid Electric Vehicles Program*, which was sponsored by the U.S. Department of Energy (DOE) using American Recovery and Reinvestment Act of 2009 funding. This report provides insight to the data that was collected on the vehicles during the original project as well as during the extended period.

Project Objective

The original purpose of the Program was to develop a path to migrate plug-in hybrid electric vehicle (PHEV) technology to medium-duty vehicles by demonstrating and evaluating vehicles in diverse applications. The Program also provided three production-ready PHEV systems—Odyne Systems, Inc. (Odyne) Class 6-8 trucks, VIA Motors, Inc. (VIA) half-ton pickup trucks, and VIA three-quarter-ton vans. The vehicles were designed, developed, validated, produced and deployed. Data were gathered and tests were run to understand the performance improvements, allow cost reductions, and provide future design changes. The objective of the extended program was to provide another ten months of collected data from the fleets and provide analysis.

Technology Description

The VIA design is a series PHEV system. The electric motor provides all the propulsion power directly to the wheels. The gasoline engine provides torque to a generator that provides power to the battery pack and traction motor. The vehicles have up to 47 miles of all-electric range before the

engine turns on and provides load-follower torque to the driveshaft while running in charge-sustaining mode. The general assembly process is that VIA purchases completed 2014 trucks from Chevrolet, eliminates the transmissions, and replaces them with generators. A motor and gearbox are attached to the prop shaft for traction torque, and two inverters are used to control the generator and the motor.

The Odyne hybrid system is a simple, parallel hybrid system that allows the torque of the electric motor to augment the torque output of the diesel engine, thus saving fuel. The motor speed is synchronized with the engine speed through the power take-off (PTO) unit. The traction motor drives the PTO, adding torque to the rear axle, or converts torque from the PTO into power to charge the hybrid batteries. Six patents have been granted, and other patents are pending.

Status

Sixty-two different utilities, municipalities, or companies participated from 23 states, as well as Washington, D.C.; British Columbia; and Manitoba. The participants demonstrated and evaluated 296 vehicles (52 VIA vans, 125 VIA pickup trucks and 119 Odyne trucks). Data were collected on each participant's trucks during normal working times to establish data for analysis. Although data collection for the project has been completed, the Program continues with the vehicles remaining in the fleet.

Results

Data were collected during the day and sent to the server daily. Data collected include the following:

- Motor, battery, charger and export power current and voltage
- Motor and engine torque and speed
- Odometer
- Vehicle speed
- Accelerator and brake pedal position
- Fuel used
- Charger time; and
- Software and calibration level.

To summarize the table below, more than 10,000 charge events (vehicles plugged in) were recorded with over 274,000 miles driven and more than 116,000 hours of data collected.

Total Summary Data

Variable	Measure	Units
All Event Types		
Number of events	67,651	Events
Number of active vehicles	272	Vehicles
Duration of all the events together	116,545	Hours
Number of Drive Events	49,708	Events
Number of Charge Events	10,150	Events
Number of Operate Events	7,793	Events
DRIVE INFORMATION		
Drive: Total Duration	11,588	Hours
Drive: Total Distance	274,615	Miles
Drive: Distance on Electric	102,298	Miles
Drive: Number of Events (CD+CS)	12,743	Events
Drive: Number of Events (CD)	30,203	Events
Drive: Number of Events (CS)	5,525	Events
Drive: Idle Duration	222	Hours
Drive: Fuel used during Drives	17,386	Gallons
CHARGE INFORMATION		
Charge: Plugged in Duration	99,386	Hours
Charge: Charging Duration	46,351	Hours
Charge: Wall Energy	105,565	kWh
Charge: Battery Energy	72,577	kWh
Level 1		
Charge Level 1: Number of charges	910	Events
Charge Level 1: Plugged in Duration	11,842	Hours
Charge Level 1: Charging Duration	6,968	Hours
Charge Level 1: Wall Energy	7,102	kWh
Charge Level 1: Battery Energy	4,278	kWh
Level 2		
Charge Level 2: Number of charges	7,373	Events
Charge Level 2: Plugged in Duration	87,405	Hours
Charge Level 2: Charging Duration	39,302	Hours
Charge Level 2: Wall Energy	98,411	kWh
Charge Level 2: Battery Energy	68,148	kWh
OPERATE INFORMATION		
Operate: Duration	6,060	Hours
Operate: Fuel Used	508	gallons
Operate: Export Electric Energy Used	987	kWh
Operate: Electricity Used	8,189	kWh

This program has accomplished the following:

- A large database for medium-duty truck PHEVs has been established.
- Fleet traits have been identified.
- Fleet fuel consumption and range have been determined.
- Charging traits have been identified; and
- More powerful charging stations are widespread.

Benefits

One of benefit of the Odyne system is to combine the fuel and emissions savings while driving with

the engine-off benefits of hybrid jobsite operation. To accurately assess the system, the combined benefits are calculated in the full-day work cycle. Using the data that were gathered on the fleet, an average day’s parameters can be calculated. The average drive distance is 26 miles, the average stationary work is complete in 2.8 hours, and the average idle time is 1.6 hours. Two calibrations were completed for the Odyne vehicles. One calibration was considered aggressive (strong), and the other was considered mild. The difference is that the aggressive calibration caused the battery energy to be depleted more quickly during the drive phase to the job site than did the mild calibration. Development tests were performed at Southwest Research Institute. The results indicated that there is improvement with both the aggressive and mild calibrations. The mild calibration improved fuel economy by 12% to 15%, and the aggressive calibration had a 30% to 46% improvement.

Project Costs

The SCAQMD provided \$250,000 in Clean Fuels funding to perform the extended data collection with EPRI cost-sharing the effort with \$93,748.

Commercialization and Applications

On the pathway to commercialization is emission certification. Both the VIA van and pickup truck are certified with the U.S. EPA. Currently, VIA is CARB compliant with executive orders from CARB indicating that the vehicles are certified with exception. The exception is that all the onboard diagnostic monitors are not being set as frequently as they should be. VIA is working on these exceptions and plans to meet the full certifications. Both the van and the pickup truck have received executive orders from CARB for vehicle sale; U.S. EPA has also approved them for sale. VIA worked with each agency to establish the requirements, and then VIA conducted and successfully passed the required tests, which included tailpipe emissions and evaporative emissions.

The extended data collection shows the durability, reliability and the lessons learned from the vehicles in real-world usage. It is imperative for a project like this to have a substantial amount of data, which was achieved from the project extension, and will be used for future development of this technology.

SCAQMD Contract #11606

November 2016

Develop and Demonstrate Plug-in Hybrid Electric Drive System for Medium- & Heavy-Duty Vehicles

Contractor

Odyne Systems, LLC

CosponsorsDepartment of Energy
Odyne Systems, LLC**Project Officer**

Joseph Impullitti

Background

Odyne Systems, LLC, has become a leading designer and manufacturer of parallel plug-in hybrid electric vehicle systems for the commercial medium- and heavy-duty truck market. The project was proposed in conjunction with a \$1.9M DOE grant to develop and validate Odyne's second-generation plug-in hybrid system for commercial production, utilizing lithium-ion battery technology.

Project Objective

The project objectives were to develop, test, validate and deploy advanced medium-heavy-duty plug-in hybrid electric vehicles for work truck applications. The primary objectives of the project were:

- To match the size of the energy storage device relative to customer duty cycle
- To improve specific aspects of the existing system through use of a lithium-ion battery system
- To optimize the system and selected powertrain components for high-volume production
- To qualify improvements in fuel economy and emissions through prototype test and deployment of two

medium-heavy-duty work trucks within the South Coast Air Quality Management District

Technology Description

The Odyne second generation plug-in hybrid system incorporates a novel approach in connecting the hybrid drive train to the vehicle offering idle reduction, regenerative braking, launch assist, climate control and exportable power. Odyne's unique, modular design interfaces seamlessly with a vehicle's transmission and can be installed on a wide range of chassis, powertrains and work truck applications. The minimally intrusive design provides both hybrid driving functionality and jobsite anti-idle electrification without significant redesign of the existing vehicle platforms.

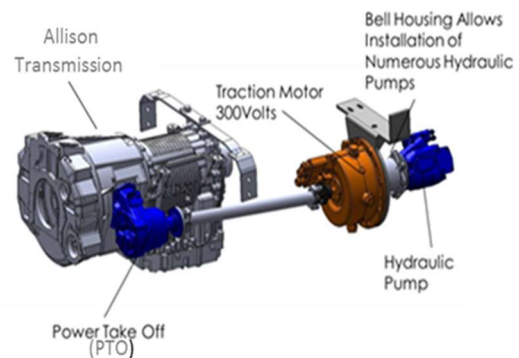
Figure 1: Odyne PHEV Powertrain**Status**

This project was completed in November 2016. The demonstration vehicles deployed at Anaheim Public Utilities and Los Angeles Department of Water and Power remain in daily use within the utility fleets.

Results

Odyne launched a ‘clean sheet design’ (i.e. developing a system from only a set of requirements) incorporating many automotive grade components and state-of-the-art lithium ion batteries (1X14kWh, 2X14kWh) produced by Johnson Controls. Full functional design validation was completed to verify performance. The testing demonstrated the capability to power equipment requiring up to 40 kW (53 HP), export 120/240V power up to 6 kW, support 12V vehicle loads up to 1.2 kW and provide 16,000 BTU of cabin heat or air conditioning.

Telematics systems were utilized to determine the real-world duty cycles for the deployment vehicles. The LADWP vehicle is utilized close to the fleet base with an average daily distance of approximately 11 miles and an average speed of just over 14 miles per hour. The Anaheim vehicle is used over a wider area with an average daily distance of 35 miles and an average speed of 23 MPH. At the job site, the LADWP unit is more heavily utilized, averaging 3.52 worksite hours vs. 1.06 hours for Anaheim.

Emissions testing was performed at the UC Riverside/CE-CERT facility. Results applied to the vehicle duty cycles determined by telematics analysis yielded the average savings displayed in Table 1.

Anaheim Avg. Full Day Emissions (35.9 Miles, 1.1 hour ePTO)				
	CO2 g	NOx g	Fuel gal	Grid Energy kWh
Conventional	71425	78.7	7.194	0.00
Hybrid	54197	62.5	5.458	4.36
Hybrid Change	-24%	-21%	-24%	X

LADWP Avg. Full Day Emissions (10.8 Miles, 3.5 hour ePTO)				
	CO2 g	NOx g	Fuel gal	Grid Energy kWh
Conventional	61474	94.5	6.192	0.00
Hybrid	16338	18.8	1.645	7.94
Hybrid Change	-73%	-80%	-73%	X

Table 1. Demonstration vehicle average daily fuel and emissions savings

Benefits

The differing results of the two vehicles demonstrates that the benefits of the Gen2 Odyne second generation Plug-in Hybrid System deployed in this project become more significant when the vehicle is more jobsite oriented. This is due to the initial focus and high value of eliminating jobsite diesel emissions. Regardless of application, the project demonstrated the capability of the system to reduce work truck fuel use and emissions. A full cycle (wells-to-wheels) analysis of the emissions results utilizing the CA-GREET 2.0 model information with the duty cycles identified demonstrated that the inclusion of wells-to-tank emissions did not significantly alter the results of Table 1.

Costs

The SCAQMD cost-share for this project was \$494,000. The Department of Energy cost-sharing project DE-EE0001077 was completed at a final contribution of \$2,986,315.

Commercialization and Applications

The Odyne system developed in this project was further deployed under SCAQMD contract #10659 funded by the American Recovery and Reinvestment Act and is now released for commercial sale. Based, in part, on the testing performed in this project, the Odyne second generation plug-in hybrid system was approved for use in California under Executive Order D-750. Odyne is continuing to work with suppliers on reducing component costs and working with supporting agencies to initiate projects to increase the driving and full-day fuel and emissions savings in order to continue to improve the customer value and return on investment.

Develop and Demonstrate Heavy-Duty Hydraulic Hybrid Vehicles

Contractor

Parker Hannifin Corporation

Cosponsors

California Energy Commission
Parker Hannifin Corporation
SCAQMD

Project Officer

Brian Choe

Background

Despite being a relatively small percentage of the vehicle population, heavy-duty vehicles represent a significant source of NO_x and PM emissions in the South Coast Air Basin. Hybridization is one of the key strategies to reduce emissions from this segment, but more studies and demonstrations are needed to match technologies to vocations with duty cycles that are well suited. For example, hydraulic hybrids are power dense, which allows them to absorb and release energy at high rates; however, these systems are not sufficiently energy dense to store a large amount of energy onboard. Based on these attributes, refuse and delivery vehicles, with intensive stop-and-go driving behavior, will be ideal applications for the technology.

Project Objective

The primary objective of this project was to demonstrate potential for fuel savings, emissions reduction and overall economic benefits of hydraulic hybrid trucks in parcel delivery and refuse collection operations. The project was also to collect real-world data to evaluate and validate fuel savings and emissions reduction benefits in comparison to that of conventional diesel-fueled vehicles.

Technology Description

Parker's "RunWise" hydraulic hybrid system uses pumps and accumulators to capture kinetic energy otherwise lost during braking, and then utilizes this stored energy to propel the vehicle from standstill. The Parker control unit interprets driver demand

and keeps the engine at or close to idle, while the hydraulic pumps/motors are used to accelerate the vehicle. This results in significantly lower fuel consumption which in turn reduces emissions. The system can turn the engine off under certain operating conditions in the parcel delivery vehicles. The vehicles are then powered by the stored hydraulic pressure only, further reducing emissions.



Figure 1: Parker's RunWise Hydraulic Hybrid System

Status

In this project, Parker Hannifin (Parker) deployed eight refuse and four parcel delivery vehicles with fleets and municipalities for an 18-month demonstration. The vehicles were equipped with an onboard telematics system to record vehicle performance, including vehicle speed, idle time, fuel consumption, collection arm cycles (refuse) and engine-off duration (parcel). This project was completed in June 2016 and a final report has been submitted to the SCAQMD.

Results

This demonstration provided data that validated that hydraulic-hybrid vehicles can be more fuel efficient and produce fewer harmful emissions when compared with diesel-powered vehicles equipped with conventional automatic transmissions.

The parcel delivery vehicles collectively covered a distance of 35,500 miles during the demonstration period, with an average fuel economy of 9.2 miles per gallon or 51% improvement versus the baseline of 6.1 mpg, and approximately 29 tons of reductions in CO₂ emissions.

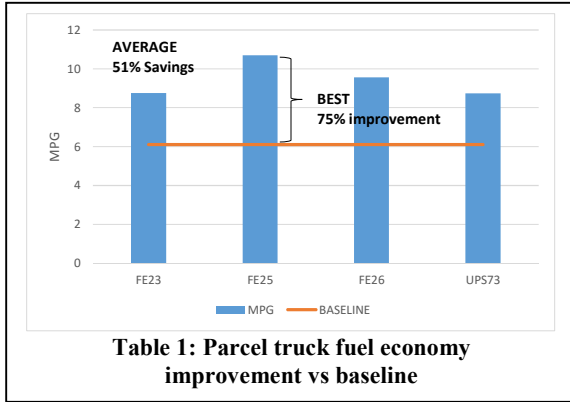

Refuse vehicles covered a distance of over 106,000 miles, with an average fuel burn rate of 2.4 gallons per hour or 47% savings versus the baseline of 4.5 gph, which is consistent with the estimated national fuel savings average for the entire North American fleet at 43%. Approximately 210 metric tons of CO₂, 921 lbs. of CO, and 203 lbs. of NO_x were eliminated by the refuse vehicles during the demonstration period. Furthermore, zero brake pad replacements were reported on both refuse and parcel delivery vehicles, and the total cost savings realized by the fleet operators, as a result of using the Parker hydraulic hybrid system, is over \$110,000 on fuel costs and \$54,000 on brake maintenance.

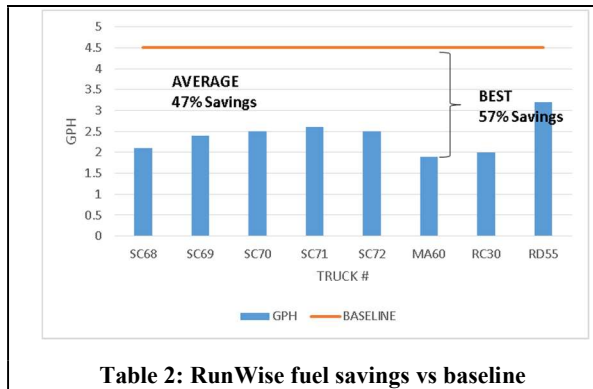

Benefits

Refuse vehicles consume approximately 50 gallons of fuel each day whereas the Parker’s hydraulic hybrid system can reduce this by an average of 47% per vehicle with corresponding reductions in emissions. Extrapolating this over the entire fleet of approximately 75,000 refuse vehicles in California, the emissions reductions could reach 1.9 million metric tons of CO₂, 8.6 million lbs. of CO and 1.9 million lbs. of NO_x.

In addition, the total cost savings achieved by the eight refuse and four parcel delivery vehicles

during the demonstration was approximately \$164,000, between fuel costs and brake maintenance. An extrapolation of these savings over the entire refuse fleet in California would yield an annual saving of over \$600 million.

Project Costs

The total project cost was \$3,925,000 with the SCAQMD and CEC cost-sharing \$250,000 and \$750,000, respectively. The remaining \$2,925,000 was cost-shared by Parker and demonstration fleets.

Commercialization and Applications

Parker’s first-generation hydraulic hybrid technology (“RunWise”), used in refuse vehicles, has been commercialized and is currently available for sale in all 50 states. This technology is unique to the refuse vehicle application and therefore market penetration is limited as approximately 10,000 Class 8 refuse vehicles are sold annually in the U.S., of which only 30% are automated side loaders, which is the ‘sweet spot’ in U.S. terms of performance optimization for this system.

The technology used on the parcel delivery vehicles is second-generation with a very broad market potential. This product, while similar in function, is lighter, less complex, more reliable and significantly less expensive than the first-generation system. This system can be applied in place of a conventional transmission in any stop/start duty cycle application—from parcel delivery vehicles to transit buses.

This second-generation product costs approximately between one-third and one-half that of the RunWise system (depending on application), providing up to 40% fuel savings, which would realize a return on investment for the end-user in two to three years. Parker expects the cost of the second-generation system to decrease even more as volume increases. Parker has completed the development of this next-generation system and would be ready to go to market if favorable demand conditions occurred in the U.S. Currently, the product is being marketed in South America and Asia.

When compared with other alternate fuel and electric hybrid technologies, this is a technology on the market today that delivers fuel and emissions savings at a price point that can provide a return within a few years of ownership and that does not require significant investment in infrastructure to deploy on a broad scale.

SoCalEV Infrastructure MOA to Install & Upgrade EV Charging Infrastructure

Contractor

Various SoCalEV partner organizations

Cosponsor

SCAQMD
California Energy Commission (CEC)

Project Officer

Patricia Kwon

to pay remaining costs. SoCalEV partners that completed their installations include the Cities of Claremont, Covina, Lake Elsinore and Palmdale; County of Los Angeles; California State University campuses at Fullerton, Long Beach, Los Angeles (Department of Water and Power), and San Bernardino; California State Polytechnic University, Pomona; and University of California Irvine. Participating installers included the non-profit Adopt-A-Charger and Associated of Los Angeles (ALA).

Background

The Southern California Regional Plug-In Electric Vehicle Plan (SoCalEV) is a regional collaborative among cities, utilities, automakers, local and regional government agencies, businesses and others in the region who are actively engaged in supporting and building the necessary infrastructure for the commercial launch of electric vehicles. The SoCalEV Ready project was funded by a CEC grant to deploy 321 Level 2 and two DC fast charging stations throughout the four-county South Coast air district, with the grant administered by SCAQMD. These chargers were deployed starting in 2013, with all installations completed by April 2016.

Project Objective

Under multiple contracts or memoranda of agreement (MOAs) executed with SoCalEV partners, chargers are sited at local government agencies, universities, hospitals, and cultural destinations to create greater availability of public charging infrastructure, supplementary to residential and workplace charging. Installations were performed either by SoCalEV partners or contracted installers with experience in commercial installations. CEC funds were used for a portion of the costs associated with hardware and/or installation, and SoCalEV partners used their own funds as required cost sharing (39%) for the CEC grant



Figure 1: Los Angeles Zoo, DC Fast Charger and Level 2 EVSE (electric vehicle supply equipment)

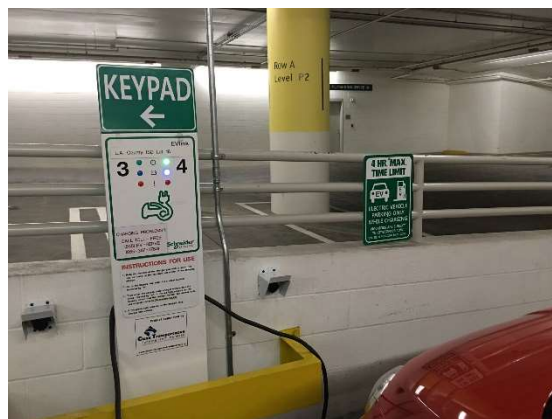

Figure 2: Los Angeles County Disney Center parking structure, Level 2 EVSE

Technology Description

EV charging stations are commercially available technology including Level 2 (240V) charging stations with SAE J1772 connectors and DC (480V) fast charging stations with CHAdeMO and CCS connectors. These connectors worked with all of the EVs available on the market: all EVs can use the J1772 connector for Level 2 charging. Asian manufacture EVs use the CHAdeMO connector while American/European manufacture EVs use the CCS for DC fast charging.



Figure 3: Getty Center parking structure, Level 2 EVSE

Status

The majority of installations were completed by December 2015, with a few installations completed by April 2016. As part of MOA terms and conditions, SoCalEV partners provided charger utilization data and lessons learned on this project. CEC sent a program evaluator in November 2015 to visit a dozen sites to confirm charger performance and high level of utilization. The following MOAs under this project were closed in 2016 and are as follows:

SoCalEV Partner	Contract #
Adopt-A-Charger	14202
Associated of Los Angeles (ALA)	14204
Los Angeles Department of Water & Power	14336

Results

In April 2016, SCAQMD created a final report to CEC on the overall deployment effort, data analysis and policy recommendations. Charger utilization data includes Table 1 below for chargers installed at California State University Los Angeles.

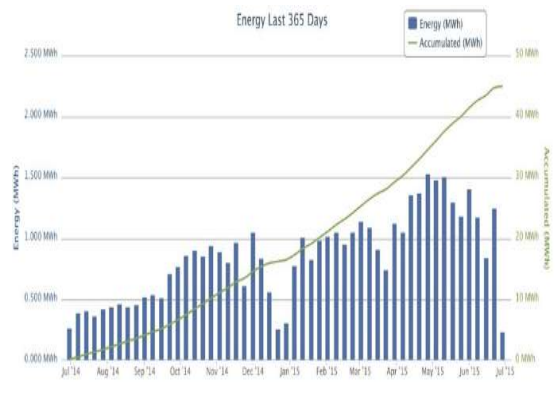

Table 1: Charger Utilization at CSULA

Benefits

This project was important in increasing the deployment of public charging infrastructure at a variety of workplaces and destinations. It also assisted in making EV infrastructure more visible to the general public addressing ‘range anxiety’, and significantly increasing the electric range of EVs to allow for longer and more frequent zero-emission trips and vehicle miles traveled.

Project Costs

The CEC grant provided funding towards hardware and/or installation in the amount of \$840,750 with SoCalEV partners providing additional cost sharing in the amount of \$542,659. Total project costs were \$1,383,409. In addition to the 321 funded installations, two DC fast charging stations were installed at the Los Angeles Zoo and Los Angeles International Airport through a partnership with Los Angeles Department of Water and Power and Adopt-A-Charger.

Commercialization and Applications

Level 2 and DC fast charging stations are fully available commercial technologies which have been and will continue to be deployed for a variety of purposes including residential, public, workplace, and destination charging. This deployment project assisted in accelerating the availability of public charging infrastructure which is much needed to go beyond the early adopter stage and have the technology embraced by the general public.

Upgrade and Demonstrate Two Electric Yard Tractors

Contractor

Transportation Power, Inc. (TransPower)

Cosponsors

SCAQMD

U.S. EPA Region IX-Clean Air Technology Initiative (CATI)

Project Officer

Richard Carlson

Background

In 2013, Transportation Power, Inc., (TransPower) developed and placed into regular revenue service two prototype electric yard tractors hauling heavy containers at a San Antonio, TX retailer facility under demanding duty cycles similar to those at port terminals, warehouse distribution centers and railyards. The tractors accumulated nearly 1,000 miles of actual service and demonstrated they could operate under the duty cycle for as long as 13 hours between battery charges.

Consequently, SCAQMD worked with TransPower to identify system improvements incorporating lessons learned from the initial deployment in San Antonio. TransPower staff believed that deploying the yard tractors upgraded with the latest TransPower energy storage and drive technology at various facilities such as warehouse distribution centers in Southern California would provide additional information on the performance of zero-emission yard tractors under various operations and facilitate user acceptance.

Project Objective

This Project included upgrading the two yard tractors with the latest TransPower energy storage, battery management

system, power controls, and drive system and then demonstrating the two yard tractors at distribution centers in the South Coast Air Basin.

Technology Description

The TransPower “ElecTruck-YT” system includes the following major subsystems:

- 160 kWh lithium iron phosphate (LiFePO4) energy storage system
- On-board 70 kW fast charger
- 150 kW PMAC electric drive motor
- 6 speed Eaton Automated Manual Transmission
- Electric accessories (power steering, battery/motor cooling system, cabin air conditioning/heating system, and alternator).

The upgraded yard tractors included the following improvements:

- adaptation of a heavier-duty transmission and shifting mechanism
- automated shifting software
- monitoring and protection of batteries when vehicles are unattended
- integration of battery monitoring and overall tractor control software
- battery management system sensor design
- electrically driven accessory inverter
- battery cell packaging to improve accessibility for servicing.

Status

Upgrade of both yard tractors was completed in 2014. In 2015 and 2016, the two yard tractors were demonstrated at a number of port terminals and warehouse terminals in Southern California. To meet the San Antonio facility requirements, the two yard trucks were built with dual rear axles. However, most facilities in Southern

California preferred single rear axle tractors due to space limitations, which unfortunately limited our demonstration site options. Nonetheless, the two yard trucks served as successful demonstration vehicles and helped commercialize the technology.



Figure 1: Upgraded Electric Yard Tractors

Results

One tractor has accumulated 350 hours and 1,560 miles in 2015 and 2016 while operating at a recycling facility and regional building material distribution center. It has operated satisfactorily except for a radiator leak caused by a broken cooling fan bracket and an inverter failure both of which have been repaired. The second tractor has accumulated 92 hours and 165 miles in 2015 and 2016. It has been used primarily as a demonstrator and show vehicle. It was also tested at Southern California Edison for evaluation of electrical loads during charging.

Benefits

The electric yard tractor project promoted the commercialization of zero-emission goods movement equipment, specifically involving ports, warehouses and distribution centers in the South Coast Air Basin. Zero-emission transportation and goods movement technologies are included within SCAG's Regional Transportation Plan and SCAQMD's 2016 Air Quality Management Plan.

This successful demonstration of battery electric yard tractors will move the technology closer to commercialization for wide-scale market deployment and the region closer to attainment of clean air standards by eliminating diesel particulate matter and NO_x emissions. Additionally, since yard tractors are used to move goods in and around warehouse distribution centers, marine port terminals, and railyards, the application of zero-emission technologies will improve the air quality in these disproportionately impacted communities.

Project Costs

The total fixed price of this contract was \$405,000 of which \$330,000 was contributed by the U.S EPA CATI program and \$75,000 was from the SCAQMD Clean Fuels Fund.

Commercialization and Applications

The technology demonstrated in this project has been commercialized. These two yard tractors serve as demonstrators of the technology and its capability to perform in commercial applications. Based on favorable responses from fleets seeing and using these yard tractors, other vehicles including yard trucks, drayage trucks, and school buses have been built or are on order.

Electric vehicles are currently produced by converting an existing vehicle. Future effort is being devoted to scaling up production by linking TransPower with one or more vehicle manufacturers that will assemble new vehicles with electric drive.

Develop, Integrate and Demonstrate Ultra-Low Emission Natural Gas Engines for On-Road Heavy-Duty Vehicles

Contractor

Cummins, Inc.

Cosponsors

California Energy Commission-Public Interest
Energy Research (PIER)
SCAQMD
Southern California Gas Company

Project Officer

Richard Carlson

- Meeting 0.02 g/bhp-hr NOx
- Meeting other 2010 pollutant standards
- Achieving 10 ppm ammonia average or as low as possible

Other objectives affecting commercial viability of the engine included:

- Minimizing fuel consumption loss vs diesel
- Maintaining same power as diesel
- Complying with U.S. EPA/CARB certification requirements
- Providing cost, performance, drive quality and durability similar to diesel.

Background

The 2012 AQMP identified heavy-duty diesel trucks as one of the largest source categories for NOx emissions. Currently and in future years, even as the legacy fleet of older and higher-polluting vehicles were to be retired and replaced with vehicles meeting the 2010 NOx standard of 0.2 g/bhp-hr. The 2012 AQMP also showed that NOx reductions in excess of 60% would be required from all source categories in order to meet future federal ambient air quality standards for ozone.

In 2012, diesel engines and diesel engine emission control technologies did not appear capable of achieving NOx emissions significantly lower than the 2010 standard. SCAQMD had previously worked successfully with engine manufacturers to introduce heavy-duty natural gas engines which had NOx emissions meeting the 2010 standards earlier than diesel engines. SCAQMD worked with CEC to develop a jointly funded program to develop a natural gas engine targeting NOx emissions 90% lower than the 2010 standard.

In 2013, SCAQMD issued a request for proposals to develop and demonstrate an ultra-low NOx natural gas engine. Cummins, Inc., was one of two organizations selected from the competitive solicitation.

Project Objectives

This project included the following emission objectives using U.S. EPA/CARB certification test procedures:

Technology Description

The engine was derived from Cummins 14.9-liter ISX15 diesel engine but had newly designed manifolds, heads, camshaft, piston, EGR, turbocharger, and catalyst after treatment, all purposely designed for optimal performance with natural gas. The final technology configuration consisted of:

- Stoichiometric air-fuel ratio
- Port fuel injection
- Big intake - small exhaust valves
- Improved cooling of head and spark plugs
- Flow-optimized intake manifold and exhaust manifold
- High energy ignition system
- Cooled EGR
- Waste-gate turbocharger
- TWC aftertreatment: close-coupled and main underbody

Status

Extensive simulation modeling was conducted to evaluate alternative design strategies. The goal was to improve the following engine characteristics: cylinder-to-cylinder variation, cycle-to-cycle variation, residual in-cylinder gases, combustion efficiency, pre-ignition knocking and pumping efficiency. These characteristics compromise performance of natural gas engines converted from diesel engines. Several test engines were

assembled as part of the design and development work. An engine containing the final internal and external engine hardware, optimized control software, and after treatment system was tested according to the cold/hot Heavy Duty Engine Federal Test Procedure (HD-FTP) and was operated without failure for more than 500 hours under a wide range of speed and load conditions.



Figure 1: Test Engine on Dynamometer

The design and integrated technology has been demonstrated using a variety of engine dynamometer tests to meet all program objectives except 10 ppm ammonia. Unfortunately, market demand for a 15-liter natural gas engine is currently insufficient to justify launching this new engine at this time. The technology is scalable over an 8- to 15-liter size range and Cummins intends to incorporate this technology in the next natural gas engine which is expected to be released in the 2019-2020 timeframe.

Results

The ISX15-G engine has achieved the following results. All except ammonia achieved and surpassed the project targets. Further optimization of software controls and the after treatment system is expected to reduce ammonia below 20 ppm.

Parameter	Target	ISX15-G
NOx	0.02	0.003
PM	0.01	0.004
NMHC	0.14	0.010
CO	15.5	1.850
Ammonia	10 ppm	58 ppm

The Brake Thermal Efficiency (BTE) target was zero or no loss compared to diesel on an equivalent energy basis. BTE in the final configuration was 11.5% higher than the baseline natural gas engine configuration resulting in a BTE loss of less than 1% compared to typical diesel engines.

Benefits

This program demonstrated that a well-designed natural gas engine can achieve both near-zero NOx emissions and thermal efficiency and performance equivalent to diesel engines. The Program provided a design pathway for developing other near-zero NOx natural gas engines with performance similar to a diesel engine.

Project Costs

A contract for \$2,061,000 was executed from the Clean Fuels Fund, which included \$250,000 and \$561,000 in revenue from CEC and SoCalGas, respectively. Cummins contributed \$1,808,000 in cost-share for a project total of \$3,869,000.

Commercialization and Applications

The engine and after treatment systems developed in this study have been shown to meet the near-zero emission targets as well as provide fuel consumption lower than current natural gas engines; and incorporate design changes to improve engine robustness, reduce maintenance, and provide improved driving performance, particularly during transient operation. Unfortunately, the low cost of diesel fuel and limited natural gas fueling facilities nationwide limit the national sales potential of this large natural gas engine. Commercialization of this natural gas engine requires new tooling, the cost of which cannot be justified by the current low sales volume of natural gas engines. As a result, this ISX15-G engine will not be certified or introduced into the market at this time.

Cummins will evaluate market conditions for large natural gas engines and can apply the technologies developed in this program to engines in the 9-liter to 15-liter size range. A number of options are under consideration for certification and eventual commercialization of the technologies developed as a result of this project in the early 2020 timeframe.

Purchase and Install New L/CNG Fueling System at Commercial Fueling Station in Temecula

Contractor

Downs Energy

Cosponsors

California Energy Commission
City of Temecula
MSRC/AB 2766 Discretionary Fund
SCAQMD

Project Officer

Larry Watkins/Phil Barroca

Technology Description

The scope of the project included: one 15,000 gallon LNG storage tank; one 2-stage pump providing 95 psig minimum differential pressure at 60 gpm; one LNG single hose dispenser and dual hose dispenser with two nozzles at 3000 and 3600 psi fast fill. Access to the LNG station would be through integration with the Commercial Fueling Network (CFN) or a Downs Energy card. Access to CNG fueling is allowed via the use of common credit cards (Mastercard, Visa, Voyager, WEX).

Background

Downs Energy sought to construct, with funding, through the support of granting agencies and local municipalities, the first publicly accessible LNG station in Southern California. This station was a critical link in the network of natural gas stations in Western Riverside County and the South Coast Air Basin. This station utilizes state-of-the-art equipment and serves a variety of light-, medium- and heavy-duty natural gas vehicles, school and transit buses, and refuse and commercial trucks traveling throughout the region. SCAQMD's efforts have increased deployment of alternative fuel vehicles and increased alternative fuel throughput in the region.

Status

The station construction was completed in April 2009. The normal startup procedures for the fueling station included a purging and cold shock process, a nitrogen leak test, and an operational demonstration of each of the station's normal operations. The on-site training took place on March 31, 2009 with all-day training in the proper operation and use of the equipment. Commissioning of the station took place on April 16, 2009.

Project Objective

The project objective included construction of an LNG and L/CNG station, providing a critical link in the network of natural gas stations in Western Riverside County and the South Coast Air Basin. The new station would have the ability to provide a throughput of 300,000 gasoline-gallon equivalents (GGE) annually.



Figure 1: CNG Station in Temecula

There were several unanticipated permitting problems with the City of Temecula due to

conditions not previously encountered for the specific building conditions of an L/CNG station. Therefore, delays were encountered with ADA (Americans with Disabilities Act) compliance which extend the project. A second delay factor was caused by inclement weather issues, which delayed the project an additional two months.

Throughput was lower than projected by year three; as a result, the five-year period of annual reporting was extended by three years for a total of eight years, ending in 2016.

Results

Obtained through construction of the L/CNG station was the availability of a fueling facility within proximity of both Northern and Southern California. The early estimates place the reduction in PM and NOx emissions with the South Coast Air Basin at approximately 15 tons.

Table 1: Throughput 2009-10 to 2015-16

Fiscal Year (Apr-Mar)	Volume (GGEs)
2009-10	29,004
2010-11	40,163
2011-12	92,725
2012-13	153,982
2013-14	141,089
2014-15	123,768
2015-16	124,797

The long-term result will be improved fuel accessibility and additional penetration of clean fuel natural gas vehicles in Southern California providing cleaner air in the region.

Benefits

Alternative fuel technology has been and continues to be a major component in achieving emission reductions from both stationary and mobile sources. This project complements existing efforts promoting

alternative fuel technology in the mobile sector, as well as facilitates market readiness for private, public, and commercial operation of natural gas vehicles.

This project benefits the environment of the South Coast Air Basin in several ways beginning with the reduction in diesel particulate emissions and the increased efficiency of having an L/CNG fueling facility located in Temecula, CA. Diesel consumption would be reduced as outlined in Table 1, below, in gasoline gallon equivalents for the Temecula station. This station creates a seamless web of fueling infrastructure along critical transportation corridors to enable low-emission natural gas vehicles to travel more freely throughout California and the western U.S.

Project Costs

LNG/CNG Grant Funding		
California Energy Commission	Equipment only	\$250,000.00
AQMD - #02061	All costs	\$250,000.00
AQMD - #05250	All costs	\$203,137.00
MSRC #MS04052	All costs	\$250,000.00
City of Temecula	All costs	\$150,000.00
Total Grant Funding		\$1,103,137.00
Project Cost		1,232,247.22
Downs Share		11.94%
		\$147,158.10

Commercialization and Applications

SCAQMD's efforts have increased deployments of alternative fuel vehicles and increased alternative fuel throughput in the region. Consumer education about alternative fuel cost savings, emission regulations and grant/tax incentives is critical to expanding the penetration of alternative fuel vehicles.

SCAQMD Contract #06042

December 2016

Upgrade Existing CNG Public Access Station with Dispenser and Card Reader

Contractor

University of California Los Angeles
Clean Energy Fuels (subcontractor)

Cosponsors

Clean Energy Fuels
MSRC/AB 2766 Discretionary Fund Program
SCAQMD
University of California Los Angeles

Project Officer

Larry Watkins/Phil Barroca

Background

The University of California Los Angeles (UCLA) was an early adopter of compressed natural gas (CNG) as a fleet fuel. The station selected for upgrade under the terms of Contract #06042 was a first-generation system, installed in 1993. The original set-up of the station included public use; however, its primary user was the UCLA fleet.

Project Objective

UCLA now operates 62 CNG fleet vehicles, including 14 CNG campus shuttle buses. To meet growing fuel demands of the UCLA fleet and public users, the facility required a system upgrade. The project objective was to replace the existing card reader located at the CNG fueling station at fleet services. The proposed upgrade would expand its potential users and bring this first-generation system to the capability and reliability level found in the state-of-the-art CNG systems installed today.

Technology Description

The selected card reader system was the FuelForce FF 814 card reader system with video training modules for first-time users. The system supports all retail credit card transactions including Visa, MasterCard and Voyager as well as Wright Express and Voyager fleet cards.

The construction of the new system included the installation of a split priority panel, a Greenfield video dispenser, and a credit card terminal.

Status

Station construction commenced in May 2008. A Grand Opening was held on August 28, 2008. A report was submitted to the SCAQMD for consideration in late 2008, but projected throughput was higher than actual gallons dispensed. As a result, the five year period of annual reporting was extended by three years for a total of eight years, ending in 2016.



Figure 1: Card Reader at UCLA

Results

We believe this project to have been a success as the station has seen an increase in transactions and gallons dispensed while remaining robust and reliable. Since completion of the facility upgrade, the UCLA station has dependably supplied CNG fuel to the campus community and local private fleets.

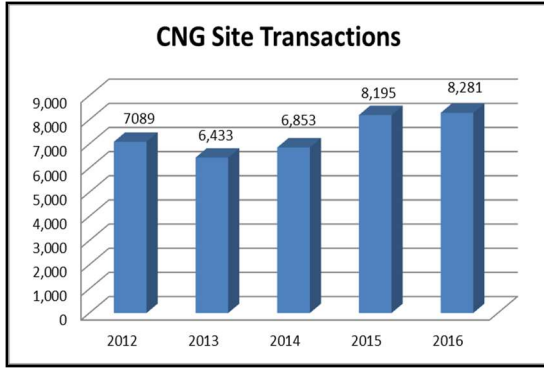

Figure 2: Station Throughput 2012-2016 (GGEs)¹

At the completion of the upgrade, an average 425 transactions were completed per month. In 2016, the UCLA site averaged 690 transactions per month, the highest number recorded. The facility is technically capable of reaching the throughput requirement of an estimated 920 transactions per month and 150,000 GGE annually.

Benefits

Fueling infrastructure does not provide emission reduction benefits or improved air quality on its own; rather, benefits are achieved from the natural gas vehicles that fuel at reliable stations such as this. The UCLA CNG station provides the UCLA fleet and private West Los Angeles users with a reliable source of fuel for their vehicles.

The UCLA CNG fleet has increased incrementally over the years, thereby reducing the number of traditional gasoline vehicles driven for campus operations. Some CNG operators have since opted for electric vehicles after feeling comfortable with an alternatively fueled vehicle, thus reducing greenhouse gas emissions even further.

Without a state-of-the-art card reader, the original first-generation station would not have been able to service the 8,300 transactions seen in 2016. As such, the upgraded card reader has facilitated a 63% increase in the volume of CNG transactions since its installation and is capable of conducting increasing numbers of transactions over the coming years.

Project Costs

At the time of contracting, the project budget was estimated at \$31,842, with the SCAQMD contributing \$15,921, or 50% of the project cost, and the MSRC (AB 2766 Discretionary Fund Program) was contributing the remaining 50%. At the close of construction, the total project cost was \$61,799, with UCLA paying the remaining project costs and Clean Energy Fuels contributing some in-kind services. The \$15,921 contributed by the SCAQMD represented 26% of the total budget.

Commercialization and Applications

Compressed natural gas as a vehicle fuel is commercially available on a limited basis throughout the South Coast Air Basin. This project expanded the transactional capacity of an existing CNG station to allow greater user access, thus expanding the viability of this alternative fuel in the West Los Angeles area.

Future card reader upgrades may include smart card Europay, MasterCard and Visa (EMV) technology, for enhanced security and expansion of payment methods. Although the UCLA Fleet would minimally interact with such a system, the EMV technology would allow for even greater access to the general public, resulting in even more use of the CNG station. The new EMV technology upgrade would cost an estimated \$13,000, which includes the additional wiring, permitting, and labor expenses to complete, acquire, and employ.

SCAQMD will continue to explore opportunities to support and fund natural gas fuel projects, as a strong network of publicly accessible infrastructure will help to support the capacity of CNG as an alternative fuel in the South Coast Air Basin. At present, natural gas is the cleanest available fossil fuel technology and provides its users and the communities in which they travel with improved air quality via reduced tailpipe emissions.

¹ Gallons of gasoline equivalent

Upgrade Existing LNG Facility to L/CNG at Riverside County Waste Management's Agua Mansa Facility

Contractor

Clean Energy Fuels

Cosponsor

SCAQMD
Clean Energy Fuels

Project Officer

Larry Watkins/Phil Barroca

Background

The SCAQMD awarded Clean Energy Fuels \$120,000 in funding to help offset a percentage of the cost to add public access CNG fueling to the County of Riverside's existing LNG fueling station located at 1830 Agua Mansa Road, Riverside, California.

Project Objective

The work to be accomplished under this award was to provide equipment funding to help offset a percentage of the capital costs incurred for a new public access compressed natural gas (CNG) fueling facility to fill an existing current gap in infrastructure in the Inland Empire region of the South Coast Air Basin. Accessible CNG fueling did not exist on the route 60 corridor between the City of Riverside and Ontario International Airport (ONT).

Technology Description

CNG station construction included the installation of a 6 GPM L/CNG pump; 3 storage vessels each with a nominal capacity of 9,400; a 3,600 psi dispenser; a priority panel and all other required station components.

Status

Station construction commenced July 2010. Station start-up processes occurred in early February 2011 and included the fueling of test vehicles. The station was commissioned and



Figure 1: Upgraded Agua Mansa L/CNG Station



Figure 2: CNG Dispenser installed at Agua Mansa LNG Station

became fully operational by the end of February 2011. The completed facility meets all required codes and passed a Fire Marshall Safety Inspection prior to the public opening.

Results

The new County of Riverside CNG station fills a critical gap in the Southern California CNG network. Clean Energy successfully completed the upgrade of the County of Riverside’s existing LNG fueling station to provide a public access CNG station. The new public access CNG station meets the specifications outlined in the award agreement and is now open 24-hours per day, 7-days a week. This contract included an annual throughput requirement of 750,975 gasoline gallon equivalents (GGEs) of natural gas by the end of the third full year of operation. As the table below shows, this throughput was met in the second year.

Five-Year Throughput Data			
Year	CNG Dispensed	LNG Dispensed	Total GGE Dispensed
2011	264,040	403,927	667,967
2012	475,367	385,783	861,150
2013	520,751	430,570	951,321
2014	718,252	498,125	1,216,377
2015	718,933	388,108	1,107,041

Benefits

Fueling infrastructure does not provide emission reduction benefits or improved air quality on its own; rather, those benefits are achieved from the natural gas vehicles that fuel at reliable stations such as this. This contract included an annual throughput requirement of 750,975 gasoline gallon equivalents (GGEs) of natural gas by the end of the third full year of operation. Based on this usage, the station would reduce

more than 913 metric tons of criteria pollutant & greenhouse gas emissions per year, a total of 4,565 metric tons of criteria pollutant & greenhouse gas emissions would be reduced over a 5-year project life.¹

Project Costs

The total project cost of the CNG public access upgrade was \$535,457. The \$120,000 contributed by the SCAQMD represented 22% of the total budget. Clean Energy Fuels provided the remaining capital of \$415,457.

Conclusions

The LNG station was effectively upgraded to include a public access CNG station, establishing a vital link in local-area alternative fuel infrastructure.

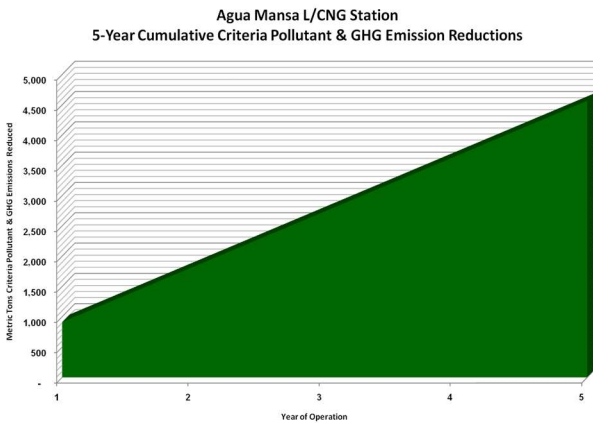

¹ Emissions reductions were determined utilizing the Clean Cities Area of Interest 4: Alternative Fuel and Advanced Technology Vehicles Pilot Program Emissions Benefits Tool. Assumptions: annual fuel throughput based on commitments

included in the original grant proposal; Heavy Duty vehicles=282,975 GGE/year & Light Duty Vehicles=468,000 GGE/year; HDV MPG= 6MPG & LD MP=15 MPG.

SCAQMD Contract #06091

December 2016

Purchase and Install New Public Access CNG Fueling Station at City Yard

Contractor

City of Whittier

Cosponsors

SCAQMD
MSRC/AB2766 Discretionary Fund
City of Whittier

Project Officer

Larry Watkins/Phil Barroca

lower overall fuel costs, and lower its dependence on imported oil.

Status

On December 11, 2007, the Whittier City Council approved awarding the construction contract to Allsup Corporation. The entire authorized amount for the station project, including construction, inspection, permitting and contingency was \$789,790. Construction began on July 22, 2008 and was completed on November 1, 2008.

Background

In 2001, the SCAQMD and the California Air Resources Board began to adopt regulations that require public agencies to embark on effectively reducing vehicle PM and NOx emissions.

These regulations prompted the City of Whittier staff to explore the alternative fuel market and the City initiated a work plan to transition its incoming fleet to clean CNG-fueled vehicles.



Figure 1: Compressor Compound

Project Objective

The objective of this project was to construct a limited-access facility to support clean natural gas powered vehicles and equipment for the City, complying with the regulations while maintaining services for fueling the general public and other fleets in the area, and to promote the use of alternative fuels.



Figure 2: Time Fill Posts

Technology Description

When the City of Whittier began to explore the alternative fuel market, natural gas was recognized as the most economical alternative fuel in this region.

Utilizing natural gas, the City is able to significantly lower its vehicle emission levels while maintaining public service levels,

Because throughput was lower than projected at three years, the five-year period of annual reporting was extended by three years for a total of eight years, ending in 2016.

Results

Concurrent with station construction, the City of Whittier had replaced seven heavy-duty refuse collection trucks (44% of its refuse fleet), one street sweeper, and three light-duty pickup trucks. By replacing those vehicles, the City reduced NOx emissions by more than 2.1 tons and diesel PM was also reduced. The City had also submitted procurements for two heavy-duty refuse collection trucks.

Benefits

The following table reflecting throughput demonstrates displacement of diesel fuel, further reducing both NOx and PM.

Period	Throughput (in Therms)
12/1/08-11/30/09	63,342
12/1/09-11/30/10	66,844
12/1/10-11/30/11	70,407
12/1/11-11/30/12	75,857
12/1/12-11/30/13	80,853
12/1/13-11/30/14	91,012
12/1/14-11/30/15	101,895
12/1/15-11/30/16	76,419

On July 1, 2016 the City of Whittier outsourced its Solid Waste Collection services, which had an impact on the CNG station load (throughput). Regardless, the City of Whittier continues to replace diesel-powered vehicles with CNG-powered vehicles.

Project Costs

Total project costs and funding sources were as follows:

Source	Amount
City of Whittier	\$497,789
MSRC/AB 2766 Discretionary Fund	\$83,333
SCAQMD	\$150,000
Total	\$731,122

Commercialization and Applications

The City of Whittier has been transitioning turnover of its heavy-duty diesel vehicle fleet to vehicles which operate by cleaner compressed natural gas (CNG) and a large component of this conversion has been the vehicle refueling station. The City experienced a longer construction time than anticipated presenting the station construction contractor with the, “Notice to Proceed” on January 1, 2008 and finishing almost a year later. The busy station construction market may indicate the use of natural gas, as a vehicle fuel, is becoming more prevalent.

The City plans to operate this facility for many years converting all 43 heavy-duty City trucks to CNG and plans to expand this facility within the next 5 to 6 years. The City also has oral agreements with other fleets to allow access to the station and is working to set up accounts for them, increasing throughput to the station.

The City’s largest obstacle, currently, is vehicle and engine manufacturers not producing OEM CNG vehicle products consistently. Ford was producing light-duty CNG powered vehicles and stopped. Larger truck manufacturers such as Sterling, Detroit Diesel, and John Deere have stopped production. With the use of natural gas becoming more popular and more refueling stations being available, if manufacturers could produce more vehicles, state governments, municipalities, and the general public would be more likely to use these vehicles, emission levels would drop, and the state could lower its dependence on imported oil.

Purchase and Install New Public Access CNG Fueling Station in Irwindale

<p>Contractor Foothill Transit</p>
<p>Cosponsors Clean Energy SCAQMD</p>
<p>Project Officer Larry Watkins/Phil Barroca</p>

costs incurred for a new public access CNG fueling facility. The station will provide a source of fuel for natural gas vehicles traveling throughout the area as well as along the 10, 60, 605 and 210 Freeways.

Background

The SCAQMD awarded Foothill Transit \$250,000 in funding to help offset a percentage of the cost to add a public access CNG fueling station on Foothill Transit’s property located at 5640 Peck Road, Irwindale, California.

Technology Description

The CNG station consists of the following components: 5 IMW compressors, 66,000 SCF (standard cubic feet) of ASME American Society of Mechanical Engineers) high-pressure storage vessels, 1 dual hose dispenser and a regenerative dryer capable of meeting SAE standard J1616 moisture requirements. Station start-up processes occurred in July and included the fueling of test vehicles. The completed facility meets all required codes and passed a Fire Marshall Safety Inspection prior to the public opening.

Project Objective

The work to be accomplished under this contract was to provide equipment funding to help offset a percentage of the capital

Status

The station was commissioned in July 2011. The new public access CNG station meets the specifications outlined in the contract and is now open 24-hours per day, 7-days a week.

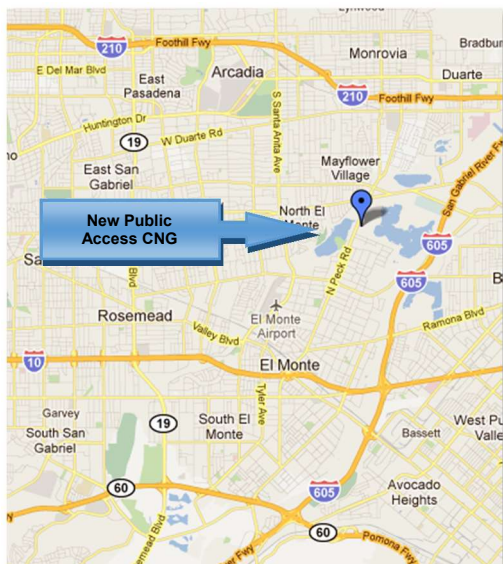

Figure 1: Station Location Near Multiple Freeways



Figure 2: Foothill Transit CNG Station

Results

Below are throughput results in gasoline-gallon equivalents (GGEs) for the five years of reporting required under this contract through mid-2016.

Period	Throughput (GGEs)
7/1/11-6/30/12	3,361,679
7/1/12-6/30/13	5,053,531
7/1/13-6/30/14	5,503,938
7/1/14-6/30/15	6,051,595
7/1/15-6/30/16	6,156,746

Benefits

Fueling infrastructure does not provide emission reduction benefits or improved air quality on its own; rather, those benefits are achieved from the natural gas vehicles that fuel at reliable stations such as this. The projected annual throughput in the proposal by the end of the third full year of operation was 900,000 GGEs of natural gas. Based on this use, this station would have reduce more than 995 metric tons of criteria pollutant & greenhouse gas emissions per year, a total of 4,976 metric tons of criteria pollutant and GHGs would be reduced over a five-year project life. This was determined using the Clean Cities Area of Interest 4: Alternative Fuel and Advanced Technology Vehicles Pilot Program Emissions Benefits Tool, and assuming annual fuel throughput based on projections included in the original proposal: heavy-duty vehicles (6 mpg) equal to 405,000 GGE/year and light-duty vehicles (15 mpg) equal to 495,000 GGE/year.

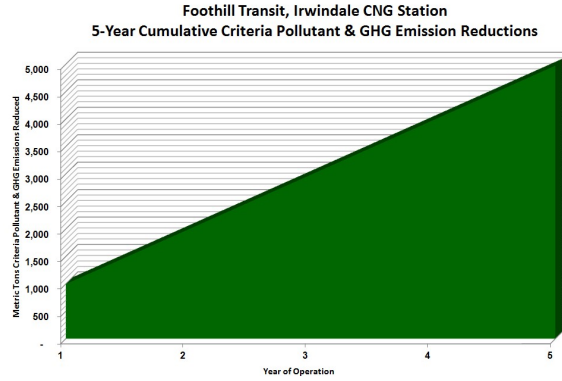

The station fell below this projected throughput during the five years of reporting so while the benefits are not as significant they are still considerable.

Project Costs

The total project cost of the CNG station was over \$3 million. The \$250,000 contributed by the SCAQMD represents 22% of the total cost. Clean Energy provided the remaining capital required to complete the station, including the required cost-share of \$909,798.

Commercialization and Applications

The station has filled a critical gap in the southern California CNG fueling network.

Install New CNG Refueling Station in the City Of Santa Ana

Contractor

Orange County Transportation Authority
(OCTA)

Cosponsors

Mobile Source Air Pollution Reduction Review
Committee (MSRC) AB 2766 Discretionary
Fund
OCTA/Local Transportation Funds
SCAQMD

Project Officer

Larry Watkins/Phil Barroca

Background

In an effort to fulfill the Orange County Transportation Authority mission of overseeing integrated bus, commuter rail and paratransit operations while also improving air quality OCTA has decided to move toward the utilization of clean fuels. In this regard, a decision was made that all new fixed-route buses would be fueled with compressed natural gas (CNG). Liquefied natural gas (LNG) was the clean fuel of choice for OCTA since 1998, but the decision was made to switch all new bus purchases to CNG. CNG is more common in the industry and continued fuel delivery problems with LNG have made this the best choice. In order to accommodate the use of CNG buses, CNG fueling facilities are required at some or all of OCTA's bus bases.

Project Objective

OCTA's objective was to construct and operate a new CNG fueling station at the Santa Ana bus base, located at 4301 W. MacArthur Boulevard, Santa Ana, CA 92704. The planned station would be able to fuel 4 buses simultaneously, each with 8,500 SCF of CNG within 5 minutes of connected fueling time. The station would utilize four single-hose CNG

dispensers for high-capacity fast-fill bus fueling to 3,600 psi and one two-hose dispenser for light-duty fast-fill fueling with a 3,000 psi hose and a 3,600 psi hose.

The CNG fueling station was designed to be capable of providing an estimated 2.5 million therms of throughput during the first year of operation, increasing to a throughput of 4.5 million therms in the fourth and fifth years of operation. The CNG fueling facility was designed to support a fleet of 250 CNG buses. Trillium was chosen as the contractor to perform the work.

Technology Description

OCTA's CNG fueling station relies on reciprocating compressors fed by pipeline natural gas; specifically four Ariel JGR/4 compressors. All gas is conditioned by a twin-tower, fully automatic, heat-reactivated natural gas dryer before being introduced to the compressors. The compressed gas is stored in four 10,000 SCF storage spheres at up to 4,500 psi. A Sierra Monitor Sentry gas detection system was installed utilizing infra-red sensors to verify that gas leaks do not exist and sound an alarm if one occurs.

Status

Station commissioning was completed in February 2008, with five years of reporting required under the SCAQMD contract. Major construction was complete by February 2007. Performance testing was delayed due to delays in receiving buses. Performance testing occurred by October 2007, but issues arose due to water in the gas. A water

main pipeline break two miles from the project site caused a natural gas pipeline failure and introduced water into the gas. The Southern California Gas Company resolved the problem and dried out the pipeline so that a successful performance test could be accomplished in February 2008.



Figure 1: Single-Hose CNG Dispensers

Results

As of October 2008, there were about 170 CNG buses operating from this location; these replace 10-20 year old diesel transit buses. On average, a 75% reduction in oxides of nitrogen was accomplished. The CNG fueling station is necessary to fuel the buses on schedule.

During the first year of operation – July 2007 through June 2008 - the fuel throughput was 1,490,274 therms. Fueling in 2007 started with five CNG buses and by June 2008 120-140 buses were being fueled. Throughput at three years had been projected at 4,000,000 therms annually but was adjusted to an anticipated 3,000,000 therms. The reduced throughput was likely due to economic conditions and resulting budgetary constraints for both OCTA and surrounding agencies which would have been using the station. As a result, the SCAQMD required three additional years of reporting through 2016. The following

table shows the actual usage for Calendar Years 2011-2016.

Table 1: Throughput CY 2011-2016

CY	Therms
2011	3,247,063
2012	2,816,738
2013	2,424,761
2014	2,619,743
2015	3,297,420
2016	3,480,544

Benefits

This CNG fueling station was designed to allow the OCTA to operate up to 250 CNG buses. Those CNG buses are replacing older diesel buses having at least 4 g/bhp-hr NOx emissions. These buses travel about 50,000 miles per year. Currently, about 170 CNG buses operate out of this location. There is a 75% average reduction in the NOx emissions for buses operating out of this location due to the CNG buses replacing diesel buses.

Project Costs

Total project costs were \$6,534,274. The SCAQMD provided a \$1,000,000 cost-share and the MSRC provided a \$200,000 cost-share. The project cost was within the budgeted amount. The remainder of the project was funded through local transportation funds.

Commercialization and Applications

OCTA moved to alternative fuels to do their part to improve air quality. OCTA's experience with the CNG station at Santa Ana encouraged it to continue with the use of CNG and install stations at the Garden Grove, Anaheim and Irvine bus bases. OCTA's experience can be duplicated and shared with others to save on fuel costs, help improve the environment and further safeguard public health.

Public Access CNG Fueling Station Upgrade for UCLA Transportation

Contractors

University of California Los Angeles
Clean Energy Fuels (subcontractor)

Cosponsors

Clean Energy Fuels
SCAQMD
UCLA

Project Officer

Larry Watkins/Phil Barroca



Figure 1: Compressor with Catwalk

Background

The University of California Los Angeles (UCLA) was an early adopter of compressed natural gas (CNG) as a fleet fuel. The station selected for upgrade under the terms of Contract #08043 was a first-generation system, installed in 1993. The original set-up of the station included public use; however, its primary user was the UCLA fleet.

Project Objective

UCLA now operates 62 CNG fleet vehicles, including 14 CNG campus shuttle buses. To meet growing fuel demands of the UCLA fleet and public users, the facility, which is located at 741 Charles Young Drive on the UCLA campus, required a system upgrade. The proposed upgrade would bring this first-generation system to the fueling capacity and reliability level found in the state-of-the-art CNG systems installed today. Clean Energy Fuels was chosen as UCLA's general contractor.

Technology Description

Station construction included the installation of a Greenfield compressor with a minimum capacity of 175 SCFM, a 4500 psi storage vessel, a split priority panel, an automated Greenfield video dispenser and a catwalk around the compressor enclosure. Station start-up processes occurred in early August 2008 and included the fueling of test vehicles.

The completed facility met all required regulatory codes and passed a Fire Marshall safety inspection prior to the public opening.



Figure 2: Station Fueling Ports

Status

Station construction commenced in May 2008. A Grand Opening was held on August 28, 2008. A report was submitted to the SCAQMD for consideration in late 2008, but projected throughput was higher than actual gallons dispensed. As a result, the five-year period of annual reporting was extended by three years for a total of eight years, ending in 2016.

Results

Fueling infrastructure does not provide emission reduction benefits or improved air quality on its own; rather, benefits are achieved from the natural gas vehicles that fuel at reliable stations such as this. The UCLA CNG station provides the UCLA fleet and private West Los Angeles users with a reliable source of fuel for their vehicles.

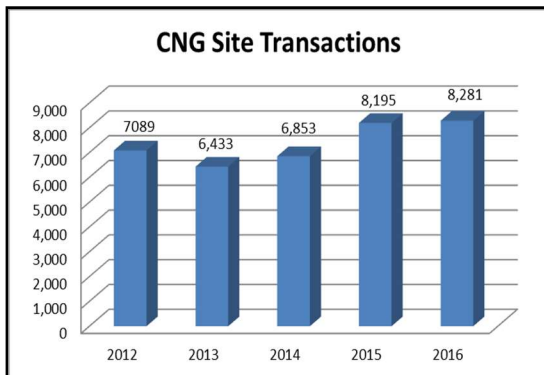

Figure 1: Throughput in GGEs¹ from 2012-2016

We believe this project to have been a success as the station was effectively upgraded from its original first-generation equipment to new state-of-the-art equipment. In 2016, the UCLA site averaged 690 transactions per month, the highest number ever recorded. The facility is technically capable of reaching the throughput requirement of an estimated 920 transactions per month and 150,000 GGE annually.

¹ Gallons of gasoline equivalent

Benefits

Since completion of the facility upgrade, the UCLA station has displaced an average of 2,500 gallons of petroleum-based fuel (GGEs) per month.

Clean Energy provides its customers with turn-key solutions for natural gas transportation fuel. As a result, station construction and upgrade is able to be standardized.

Project Costs

At the time of contracting, the project budget was estimated at \$318,158 with the SCAQMD to contribute \$140,000, or 40% of the project cost. At the close of construction, the total project cost was \$335,353. The \$140,000 contributed by the SCAQMD represented 35% of the total budget. Clean Energy provided cost-share totaling \$154,262 with the remaining budget paid by UCLA.

Commercialization and Applications

Compressed natural gas as a vehicle fuel is commercially available on a limited basis throughout the South Coast Air Basin. This project expanded the fueling capacity of an existing CNG station to allow greater user access, thus expanding the viability of this alternative fuel in the West Los Angeles area.

SCAQMD will continue to explore opportunities to support and fund natural gas fuel projects, as a strong network of publicly accessible infrastructure will help to support the capacity of CNG as an alternative fuel in the South Coast Air Basin. At present, natural gas is the cleanest available fossil fuel technology and provides its users and the communities in which they travel with improved air quality via reduced tailpipe emissions.

Install Limited-Access CNG Refueling Station

Contractors

Beaumont Unified School District
Gas Equipment Systems, Inc.
Bogh Construction, Inc.
WLC Construction Services, Inc.
Elrod Fence Company
Southern California Gas Company

Cosponsors

City of Beaumont
SCAQMD

Project Officer

Larry Watkins/Phil Barroca

Technology Description

The following equipment was installed as part of this project:

- (1) Gardner Denver CNG compressor skid
- (1) desiccant absorber gas dryer, Xebec, PST or equal
- (1) 3 band CNG storage units
- (1) fast-fill dispenser
- (1) card reader
- (1) high-pressure filter assembly
- (1) dome load-priority panel
- (8) GESI single hose time-fill assemblies with vented valves and NGVI Type II P36 fill nozzles.

Background

The City of Beaumont and Beaumont USD explored all avenues available to them in order to meet regulations for public agencies to reduce vehicle PM and NOx emissions. In June of 2004 the City received a grant award in the amount of \$150,000 from SCAQMD to construct a CNG fueling station. Due to circumstances beyond their control, the property allotted proved unsuitable for this purpose. Meanwhile, Beaumont USD had been researching ways to reduce PM and NOx emissions produced by their student transport buses.

Project Objective

The primary objective of this project was to construct a CNG fueling station on Beaumont USD's property to provide time-fill refueling to their current and growing fleet of CNG school buses overnight. A key objective was to also accommodate the City, other local entities with fleets of CNG vehicles, and the general public's CNG fueling needs. This meant there was a need to provide general access to the CNG station 24-hours a day, 7-days a week without adding personnel costs to the School District. Adding a card reader to the fast-fill station was added to the objectives.

Status

On September 25, 2007, Beaumont USD's Board of Trustees approved an award to Gas Equipment Systems, Inc. to provide services and equipment for the CNG fueling station. Construction began October 1, 2007 and was completed on August 12, 2008. The CNG Fueling station project was completed and opened to the public on September 8, 2008. The card reader allowed users to easily utilize the



Figure 1: Time-Fill Posts Allows Beaumont USD to Fill 8 Buses Overnight

station using major credit cards including MasterCard, Visa, Voyager and Wright, as well as ATM cards that have the Visa or MasterCard logo. Initial throughput for the new CNG

station from August 2008 through February 2009 was 16,943 units.

Projected throughput was higher than actual gallons dispensed. As a result, the five-year period of annual reporting was extended by three years for a total of eight years, ending in 2016.

Results

The addition of a CNG fueling station in Beaumont has helped to decrease emissions and also assists the region collectively to reduce dependence on imported oil. The district has seen financial savings in the cost of natural gas vs. diesel expenditures. Beaumont USD was able to take advantage of labor savings by utilizing the onsite overnight time-fill stations instead of having staff drive the CNG vehicles outside of the City and wait while the tanks fill. Additionally, they no longer pay a markup to another fuel facility and are eligible for the IRS fuel rebate.

Throughput in the first five years of station construction continued to grow. The following table reflects throughput in CNG therms and diesel-gallon equipment (DGEs) or diesel gallons displaced by CNG.

Table 1: Throughput 2008-2013

Period (Jul-Jun)	CNG Therms	DGE
2008-09	28,534	22,848
2009-10	32,882	26,329
2010-11	45,194	36,188
2011-12	54,411	43,569
2012-13	46,564	37,285
2013-14	62,195	49,800
2014-15	67,336	53,917
2015-16	61,761	49,453

Benefits

The District has put in place a plan to replace their older diesel-burning buses with cleaner burning CNG buses in spite of budget restraints. Moving to CNG-fueled school buses will significantly reduce NOx, PM, and air toxic emissions, contributing to overall cleaner air for the region.



Figure 2: Beaumont USD’s Public Dispenser

Project Costs

Total construction costs were as follows:

Construction Costs	
Gas Equipment Systems, Inc.	\$492,098
Bogh Construction, Inc.	\$109,294
WLC Construction Services, Inc.	\$66,016
Elrod Fence Company	\$6,723
Southern California Gas Co.	\$11,703
Total	\$685,833

Funding was provided by the SCAQMD in the amount of \$150,000, with the MSRC/AB 2766 Discretionary Fund Program providing \$288,000. Beaumont USD through its Capital Outlay Fund paid the remaining costs of \$247,833.

Commercialization and Applications

Beaumont USD plans to operate this facility for many years and has put in place a plan to convert their heavy-duty diesel vehicles to cleaner burning CNG buses when funding allows. They anticipate that as natural gas use becomes more familiar, manufacturers will meet the needs of the public and produce more vehicles that consume this cleaner-burning fuel. When this happens, it will allow the school district and other entities to additionally replace their fleet of small trucks and utility vehicles with cleaner-burning vehicles.

Install Mountain Safety Equipment on CNG School Buses

Contractor

Rim of the World Unified School District

Cosponsors

SCAQMD

Project Officer

Ranji George

Background

Using funding authorized by Proposition 1B, SCAQMD provided significant incentives to school districts to replace their old, higher-polluting school buses with new, primarily CNG, school buses. Rim of the World Unified School District was one of the grantees under this Program. Using SCAQMD's school bus grant funds, Rim of the World USD purchased 11 new CNG buses through manufacturer BlueBird's local distributor, AZ Bus Sales. Rim of the World USD operates its buses on challenging mountain roads and under severe weather conditions, at elevations that reach as high as 4,500 to 6,000 feet above sea level. Areas served by Rim of the World USD include Crestline, Lake Arrowhead, Running Springs and Green Valley Lake communities.

Project Objective

In addition to providing new CNG school buses, SCAQMD used the Clean Fuels Program to provide funding for the installation of mountain safety equipment to enhance the safety and reliability of these new CNG buses. The new equipment was to enable the school district

to operate these new buses safely on mountain roads.

Technology Description

The proposed safety equipment for the new school buses assists in helping improve traction, braking and visibility during driving. This is essential for school buses operating on steep mountain roads and curves, especially winter weather conditions which may result in ice and/or snow on the road.

The following specialized equipment was installed on these buses under these two school bus grants:

- a) Allison 3000 PTS Transmission with Retarder
- b) Rear Air Ride Suspension
- c) 10 inch Air Brakes ILO Standard
- d) Electric Air Drain Valves ILO Manual
- e) Heated Remote Mirrors ILO Heated only
- f) Additional Floor Mounted Heater
- g) Strobe Light with Pilot
- h) Fog Light Front Bumper
- i) Stainless Steel Step Well
- j) Sanders
- k) Block Heater



Figure 1: Type D CNG bus purchased by Rim of the World

Commercialization and Applications

Installation of this mountain safety equipment ensured that Rim of the World USD would continue on a path to using alternative fuel school buses, thereby reducing toxic diesel pollutants, especially exposure to young people, who are far more susceptible to the adverse health risks of poor air quality.

Status

The 11 new CNG buses awarded by SCAQMD were equipped with the above special safety equipment in 2011 and were required to operate and report for a minimum of five years under these grants. Currently, all 11 new CNG buses are still operating with the mountain safety equipment, reducing potential for hazards involved in driving school buses at high elevations.

Results

This new equipment has enabled the school district to successfully operate their new CNG school buses safely for several years.

Benefits

New CNG buses emit dramatically reduced air pollutants (NO_x, PM, air toxics) relative to the old diesel school buses that were replaced (models 2006 and earlier). The equipment installed in each bus considerably enhanced the safety and operability of the new buses at high elevations.

Project Costs

The cost of the safety additions per bus was on average \$13,170 for a total of \$144,870 provided by the Clean Fuels Program.

SCAQMD Contract #13401

May 2016

Demonstrate Natural Gas-Powered Parking Lot Sweepers

Contractor

Nite-Hawk Sweepers, LLC

Cosponsors

GoNatural CNG

Haaker Equipment

Isuzu

Nite-Hawk Sweepers, LLC

Pro-Sales

SCAQMD

Project Officer

Phil Barroca

Background

The parking lot sweeper population in the SCAQMD jurisdiction is estimated between 500-700 vehicles. In addition, there are an estimated 100+ private fleet operators providing sweeping services in locations such as retail shopping centers, office parks, shopping malls, school/university campuses and communities overseen by residential homeowner associations. Parking lot sweeper (PLS) vehicles range from converted light- and medium-duty pickup trucks to more sophisticated and purposefully designed vehicles. These vehicles fill a niche not covered by larger more robust, heavy-duty, street sweeping vehicles which are regulated under the SCAQMD Fleet Rule 1186.1. PLS vehicles can accrue as many as 60,000 miles annually and are powered by conventional fuel (gasoline or diesel) engines, representing a significant amount of emissions in this region. In December 2012, the SCAQMD Board awarded up to \$90,000 from the Clean Fuels Fund to Nite-Hawk Sweepers, LLC, based in Seattle, WA, based on their proposal to develop and demonstrate a CNG-powered PLS vehicle. Nite-Hawk develops and markets specially designed street sweepers such as the Osprey and Raptor sweepers. The CNG PLS in this project is based on the Raptor design.

Project Objective

Diesel and gasoline-powered parking lot sweepers (PLS) are widely used to clean parking lots in retail shopping centers, office parks, multi-level parking

garages, and similar locations. The implementation of new alternative fuel-powered PLS vehicles in public and private fleets that provide such services could generate important emission reductions and reduce exposure to toxic diesel particulate emissions for residents residing near locations where these vehicles are utilized. This project demonstrates a CNG-powered prototype parking lot sweeper that is based on the Raptor sweeper designed and built by Nite-Hawk. The vehicle uses an Isuzu NPR-HD chassis and is powered by a dedicated CNG-powered GM 6.0L spark-ignited V8 engine using a CARB-certified CNG conversion system. The vehicle is designed to hold up to 60 GGE of onboard CNG fuel. The project objective is expected to result in the commercial availability of a dedicated CNG-powered parking lot sweeper vehicle and to provide greater awareness of alternative fuel powered vehicles to a customer base accustomed to conventional fueled vehicles.

Technology Description

The CNG powered PLS vehicle uses a GM spark-ignited 6.0L gasoline engine converted to operate on CNG. A factory installed Engine Control Unit (ECU) monitors various engine sensors and controls engine operations with various actuators. Engine performance is optimized by using CNG's high octane rating and increasing the air/fuel ratio from 14.7:1 (stoichiometric) to 17.2:1 (lean burn). The CNG version is 30% lower in NOx emissions relative to the gasoline version and the lean-fuel mixture provides greater fuel economy.



Figure 1: CNG Nite-Hawk Raptor Edge

Status

Nite-Hawk successfully developed, demonstrated and deployed, in the South Coast Air Basin, a CNG-powered parking lot sweeper vehicle. The now commercially available PLS vehicle is built on an Isuzu NPR-HD chassis rated at 14,500-lbs GVWR and is powered by a GM 6.0L V8 engine converted to CNG-power with a CARB-certified system by Greenkraft (Santa Ana, CA). The vehicle's body is Nite-Hawk's Raptor Edge. Engineering included relocating (and redesigning) the toolbox from the center to the back of the chassis and placing the CNG tanks at center chassis. The vehicle comes with two CNG fuel capacity options: 30 GGE in a single tank or 60 GGE with two identical 30 GGE tanks. The CNG tanks are Type 4 composite cylinders.

The original project called for the development of a medium-duty, CNG-powered PLS on an Isuzu chassis with the Raptor body. Nite-Hawk solicited GoNatural CNG to develop the CNG conversion system and achieve CARB certification. Shortly after completing development of the prototype PLS and commencing demonstration in California in February 2014, GoNatural CNG ceased support of the project and subsequently closed business.¹ Nite-Hawk, unable to find a company to continue these efforts decided to use Greenkraft's CARB-certified CNG conversion system for the 6.0L GM engine in an Isuzu NPR heavy-duty chassis.

Results

The dedicated CNG-powered parking lot sweeper was demonstrated to 21 public or municipal based entities through Haaker Equipment Company, and 15 private sweeping contractors through Pro-Sales Group, Inc. between 2014 and 2016. The vehicle was deployed at airports, apartment complexes, condominium parking lots, construction sites, fairgrounds, streets, parking lots, parks, paths, and shopping centers. Participants found no difference from using a gasoline-powered sweeper and found no performance deficiencies. A common concern was sufficient access to CNG refueling infrastructure. The overall response of the participants to the CNG PLS was favorable.

The CNG PLS accrued over 14,000 miles over a two-year demonstration period with each participant driving the vehicle from 150 to 1000 miles; the average demonstration was 400 miles. A

total of 2,060 GGE was consumed; the miles per GGE ranged from 5 to 9.3; the overall average fuel economy was 6.75 miles/GGE. Nite-Hawk reports that a comparably equipped and powered gasoline version has an average fuel economy of 5.7 miles per gallon. On average, a Raptor PLS accrues 36,500 miles and has a 5 to 10 year lifespan. Regional fuel prices during the 2014-2016 CNG PLS demonstration averaged \$2.17/GGE for CNG and \$2.93/gallon for gasoline. Nite-Hawk estimates that \$1,565 in fuel savings was realized from CNG refueling in this demonstration period.

Benefits

Relative to its gasoline-powered counterpart, the CNG version of this vehicle is nearly 50% cleaner in non-methane hydrocarbon + oxides of nitrogen emissions based on CARB certification values. The use of renewable natural gas would greatly reduce GHG impacts associated with vehicle operation as well as displace the use of petroleum-based fuels. The full benefits of this program are yet to be determined.

Project Costs

Total cost for this project was, as projected, \$200,000. SCAQMD's contribution from the Clean Fuels Fund was \$90,000. Additional in-kind contributions were provided for vehicle leasing, upfits, engineering and CNG conversion as well as the two-year demonstration of the vehicle in the South Coast Air Basin.

Commercialization and Applications

The dedicated CNG-powered Nite-Hawk Raptor Edge Parking Lot Sweeper became commercially available in California in 2014. The 2017 vehicle price differential is \$28,000-\$33,000 greater for the CNG model relative to the gasoline model (less incentives). California sales include City of Palm Springs Airport, Port of San Diego, and City of Exeter. Prospective sales inquirers include Waste Management, Los Angeles, CA and Los Angeles International Airport.

¹ Following 2013, no manufacturer certified with CARB a dedicated CNG system for a medium-duty 6.0L GM engine in a medium-duty Isuzu chassis.

Cost-Share Next Sustainable Transportation Energy Pathways (STEPS) Program

Contractor

UC Davis Institute of Transportation Studies

Cosponsors

7 energy providers
9 automakers
6 Public agencies

Project Officer

Lisa Mirisola

Background

NextSTEPS (Sustainable Transportation Energy Pathways) was a four-year (2011-2014), multidisciplinary research consortium at the UC Davis Institute of Transportation Studies. The mission was to generate new insights about the transitions to a sustainable transportation energy future and disseminate that knowledge to decision-makers in the private sector and governmental agencies so that they can make informed technology, investment, and policy choices.

NextSTEPS researchers developed the theory, tools and methods that allow for self-consistent and transparent comparisons of promising alternative energy and vehicle pathways and development of realistic integrative scenarios toward sustainable transportation goals. The NextSTEPS program followed previous UC Davis Institute of Transportation Studies (ITS-Davis) consortium-based research programs on Fuel Cell Vehicle Modeling (1998-2002), Hydrogen Pathways (2003-2006) and Sustainable Transportation Energy Pathways (STEPS) (2007-2010).

Over 200 research publications and reports produced by NextSTEPS researchers are

currently available to the public at the following link www.steps.its.ucdavis.edu.

Project Objective

The NextSTEPS Program had input from a team of multi-disciplinary researchers and support from energy companies, automotive manufacturers and government agencies. NextSTEPS analyses include a focus on Southern California as the early market for alternative fueled vehicles, specifically hydrogen fuel cells, plug-in hybrid and battery electric vehicles.

Four specific STEPS projects are described below that have direct relevance to SCAQMD.

Project 1-Transition Scenarios for Alternative Fuels and Vehicles in California (Project # NS86)

NextSTEPS provided stakeholders with two overarching research updates on scenarios and transition strategies of the planned and potential rollouts of alternative vehicles and fuels in California, in order to help inform investment decisions.

NextSTEPS researchers looked at transitions for several types of fuels and vehicles:

Hydrogen - Adoption of H2 fuel cell vehicles is being spurred by new regional stakeholder partnerships, coordinating rollout of vehicles and stations. NextSTEPS transition models show that H2 infrastructure design, economics and consumer utility are improved by “cluster strategy,” co-locating early adopters and early stations.

Biofuels – “Incremental” and “Transitional” biofuel investments show the most potential currently (for example, improved corn ethanol technology); “Leapfrog” technologies

(biomass gasification, cellulosic ethanol) are still important for the long term.

Project 2- Consumer Behavior & Vehicle Choice: Longitudinal Tracking Study (Project #NS38)

NextSTEPS provided critical data on consumer perceptions and use of light-duty alternative vehicles over time, which can be used as input to develop strategies for market growth and infrastructure development. Ultimately, the management tools recommended by this study can inform forecasts of transportation fuel demand, retail fuel prices, and shifts in fuel types and vehicle types for stakeholders including the California Energy Commission.

Analysis of early plug-in electric vehicle markets and conditions for growth: Case studies of California and Norway show that the market starts in pockets, loosely characterized as urban, affluent, educated, techies. Public infrastructure is important for growth. A study of California dealers shows that dealers are integral but overlooked in selling PEVs.

Project 3-Best Policy and Incentive Strategies (Project #NS88)

NextSTEPS advised stakeholders on possible policy tools to address goals and to spur the successful early-stage development of alternative vehicles and fuels.

The ITS CA-TIMES energy/economic model was developed by STEPS researchers Sonia Yeh and Chris Yang to explore the prospects for future transportation fuels in California. They found a range of scenarios that enabled deep cuts in GHG emissions (60-80% by 2050), characterized by improved vehicle efficiency, lower carbon fuels, electricity and H₂, and overall reductions in energy demand.

Project 4- Low Carbon Options for Non-Light Duty Vehicle (LDV) Subsectors (NS28)

NextSTEPS shall assess low-carbon options for all non-light duty vehicle (non-LDV) subsectors (trucks, buses, rail, marine, and aviation), to help stakeholders evaluate

options for AB 118 funding for non-LDV transportation subsectors.

Natural Gas - Abundant natural gas is changing the economics of alternative fuels and opening new opportunities in the U.S. medium/heavy duty trucking sectors.

Status

The NextSTEPS Program, including the four projects listed above, was completed in December 2014.

Results

From 2011 to 2014, NextSTEPS researchers produced over 208 major publications and journal articles as well as numerous research reports. In addition, the Program held 16 symposia, sponsor meetings, and policymaker outreach events in California and Washington D.C. The STEPS website (www.steps.ucdavis.edu) hosts electronic copies of selected publications and other program materials.

Benefits

The NextSTEPS Program, and especially the four projects highlighted above focusing on zero emission vehicles and low-carbon fuels, have a direct relevance to SCAQMD's priorities in evaluating changes to criteria emission levels and vehicle technology options.

Project Costs

SCAQMD contributed \$120,000 toward the NextSTEPS Program for 2013 and 2014. The NextSTEPS Program was supported by other industry and government sponsorships and contracts, and the total support was over \$6 million over the length of the NextSTEPS Program (2011-2014).

Commercialization and Applications

In addition, outreach and communication of results from the NextSTEPS Program will broaden the public knowledge base and help expedite introduction of zero and near-zero emitting vehicles in the South Coast Basin.

Retrofit Digester Gas Engine with Noxtech® Aftertreatment Emission Control Technology

Contractor

Eastern Municipal Water District

Cosponsors

Eastern Municipal Water District
SCAQMD

Project Officer

Al Baez

Background

SCAQMD Rule 1110.2 - Emissions from Gaseous and Liquid-Fueled Engines significantly reduces emission limits for nitrogen oxides (NOx), volatile organic compounds (VOCs), and carbon monoxide (CO) for internal combustion (IC) engines. The Eastern Municipal Water District operates 57 prime internal combustion engines, which include four digester gas-fueled IC engines at their Regional Water Reclamation Facilities. The amended rule requires biogas fueled engines to meet lower emission limits. The SCAQMD Governing Board directed staff to conduct a technology assessment to determine potential cost-effective available technologies to achieve the limits for biogas applications. This pilot study at EMWD's Temecula Valley Regional Water Reclamation Facility was performed as part of this requested assessment.

Project Objective

This pilot test study was to evaluate the ability of the Noxtech aftertreatment system to meet the requirements of the amended Rule 1110.2 for biogas applications.

Technology Description

Eastern Municipal Water District's Temecula Valley Regional Water Reclamation Facility (TVRWRF) utilizes two biogas internal combustion (IC) engines, supplemented by natural gas as needed, to drive aeration blowers for the wastewater treatment process. For this pilot study, the engine exhaust piping for the two biogas engines was modified to vent to the Noxtech

reactor for exhaust after-treatment. The Noxtech system is designed to remove NOx, VOC, and CO from the engine exhaust through the patented Noxtech technology, that consists of: a self-sustaining auto thermal combustion process in a reaction chamber and utilizes urea, a low-cost nonhazardous liquid chemical, to chemically treat the exhaust gases. The system utilizes supplemental fuel to maintain an optimal reaction temperature, and fuel consumption is minimized by recovering heat released for temperature control and reaction optimization.

The Noxtech system differs from other biogas engine after-treatment controls, such as selective catalytic reduction (SCR), because it does not use a catalyst and therefore does not require a biogas clean-up system. Catalysts are generally highly susceptible to the impurities in the raw biogas which can typically poison, foul and plug catalysts; therefore, gas cleanup systems are required for those catalyst systems.

Throughout the pilot study, NOx and CO concentrations were measured at the inlet and outlet of the Noxtech reactor using a portable analyzer. This testing was conducted at least weekly or every 150 operating hours. Concentrations of NOx, CO, VOC and ammonia were measured using U.S. EPA and SCAQMD compliance methods during source testing. In addition, digester gas and ammonia samples were collected and analyzed periodically throughout the pilot study.

Status

The construction and installation of the Noxtech equipment at the TVRWRF began in March 2014. The Research and Development Phase, including initial commissioning, commenced in September 2014. The pilot study period and associated data collection commenced April 20, 2015 and ended January 18, 2016. There were a few periods of system downtime during the pilot study, which included a reactor inspection in July 2015, and a lengthy reactor shutdown as a result of biogas unavailability between September 29, 2015 and December 1, 2015. The majority of the testing was conducted with one engine operating on 100% biogas vented to the Noxtech due to issues

encountered with the engine isolation valves. Source testing was conducted on January 5, 2016 by SCEC (now Montrose Environmental), a CARB-approved independent testing contractor.

The Noxtech system was shut down on February 5, 2016 and testing for the pilot study was completed.



Figure 1: TVRWRF Noxtech® Reactor

Results

1. The overall compliance rate with the future Rule 1110.2 biogas concentration limits during the pilot demonstration period was 52% for NO_x and 95% for CO based on the portable analyzer testing conducted.
2. Using the NO_xtech control, the average exhaust stack concentrations throughout the pilot demonstration following portable analyzer testing protocols were 12.5 ppmvd NO_x and 145 ppmvd CO (both corrected to 15% O₂). The average NO_x concentration did not meet the future biogas limit of 11 ppmvd @ 15% O₂.
3. Using the NO_xtech control, the average exhaust stack concentrations during the source testing by SCEC conducted on January 5, 2016, were 11.92 ppmvd NO_x and 84.58 ppmvd CO (both corrected to 15% O₂.) The average NO_x concentration did not meet the future biogas limit of 11 ppmvd @ 15% O₂.
4. The VOC concentration at the stack exhaust based on SCAQMD Method 25.3 testing conducted by SCEC averaged 2.34 ppm @ 15% O₂; this is below the future biogas limit of 30 ppm @ 15% O₂ in Rule 1110.2.
5. The overall compliance rate for the free ammonia concentration sampling in accordance with SCAQMD Method 207.1 was 50%. There were four ammonia sampling events during the pilot period, two of which

exceeded the permitted limit of 10 ppm @ 15% O₂ for ammonia slip.

6. The reliability of the urea injector components and the NO_x analyzer selection may benefit from additional testing to determine the equipment life expectancy and whether an alternative, more suitable component is available.

Benefits

The use of the Noxtech system generally reduced NO_x, VOC, and CO emissions from the engine. However, the NO_x reductions were not consistently below the amended Rule 1110.2 biogas limits and in some cases CO emissions increased. The pilot study demonstrated that aside from sample conditioning for the continuous analyzers, a digester gas clean-up system is not required for the Noxtech system.

Project Costs

SCAQMD provided \$85,000 from the Clean Fuels Fund for this project. EMWD funded the remaining costs for total project costs of \$889,000.

Commercialization and Applications

The capital costs to design, procure and install the Noxtech system will vary depending on the site. The estimated cost of a reactor is \$400,000 and the installation cost for the pilot study installation of the two dual fuel blower engines at the TVRWRF was approximately \$525,000. EMWD staff invested significant additional staff resources throughout the Research and Development Phase as well as the Pilot Demonstration Phase of this test program to make system improvements to resolve short-term problems and identify long-term solutions for the challenges faced during this study. EMWD spent approximately \$1.35 million dollars on the TVRWRF Noxtech installation and pilot study. EMWD staff estimates the capital costs for a system similar to the unit installed at the TVRWRF, for two engines, to be up to \$1.8 million dollars. The annual estimated O&M costs for the Noxtech system are approximately \$77,000. Assuming a 10-year lifespan, the total annualized cost (estimated capital and O&M) is \$242,000. The dollars per ton of NO_x reduced are estimated to be \$579,340. The dollars per ton of VOC reduced are estimated to be \$222,510.

Determining the Physical and Chemical Composition and Associated Health Effects of Tailpipe PM Emissions

Contractor

University of California Riverside/College of Engineering-Center for Environmental Research & Technology (CE-CERT)

Cosponsors

California Energy Commission
SCAQMD

Project Officer

Brian Choe

Technology Description

As part of this study, physicochemical, and toxicological properties of PM emissions were investigated from one GDI passenger vehicle and two flexible fuel vehicles (FFVs), with port fuel injection (PFI) and direct injection fueling, respectively. This study emphasized the fuel type, composition, and blend level impacts on exhaust emissions and their potential toxicity. The study included both low and high level blends of ethanol and butanol, including E10, E20, Bu16, E51, E83, and Bu55. All testing was conducted on a 48-inch single-role electric dynamometer and a Pierburg Positive Displacement Pump-Constant Volume Sampling system was used to obtain certification-quality measurements. This was a collaborative study led by the College of Engineering-Center for Environmental Research & Technology (CE-CERT) at the University of California, Riverside, with support from the University of California, Los Angeles (UCLA) for toxicological analysis.

Status

This project has been completed and final reporting submitted in June 2016.

Results

PM mass, particle number, and black carbon emissions from the two GDI vehicles were found at higher levels than the PFI-FFV, due to incomplete fuel droplet evaporation and droplet impingement onto the piston and cylinder walls from the direct spray of fuel into the combustion chamber, leading to locally rich fuel combustion or pyrolysis that is prone to PM formation. For the FTP, PM mass ranged from 1.23 to 2.74 mg/mile for the PC-GDI, from 0.79 to 3.06 mg/mile for the PFI-FFV, and from 1.68 to 4.85 mg/mile for the GDI-FFV. For the UC test cycle, PM mass ranged from 0.68 to 2.53 mg/mile for the PC-GDI, from 0.73 to 1.49 mg/mile for the PFI-FFV, and from 1.15 to 4.83 mg/mile for the GDI-FFV. Overall, the use of higher alcohol content fuels resulted in lower PM mass emissions

Background

In recent years, governmental agencies around the world have implemented legislation that supports the use of alternative and/or renewable fuels in the transportation sector to reduce GHG emissions. In California, the Low Carbon Fuel Standard (LCFS) was implemented beginning in 2011 to reduce the carbon intensity of transportation fuels by 10% by 2020. Among the different oxygenated biofuels being used globally today, ethanol is the most widely employed, particularly in the U.S. Higher alcohols, such as butanol, have also been the subject of increased interest as potential fuels. With an increase in the use of ethanol and other biofuels to lower carbon intensity, it is important to analyze and test these fuel blends to better understand the impacts that changing fuel composition will have on exhaust emissions and in turn on ambient air quality, especially from gasoline direct injection (GDI) vehicles that are the fastest growing market segment in the automobile industry as manufacturers introduce more GDI models to meet new and more stringent fuel economy standards.

Project Objective

The objective of this program was to characterize physicochemical and toxicological properties of PM emissions from GDI vehicles when operating on different ethanol and iso-butanol blends.

for all three vehicles during FTP and UC operations, with the exception of the PFI-FFV. The GDI-FFV exhibited substantially higher soot emissions than the PFI-FFV, suggesting that the PM from the GDI-FFV was primarily elemental carbon in nature.

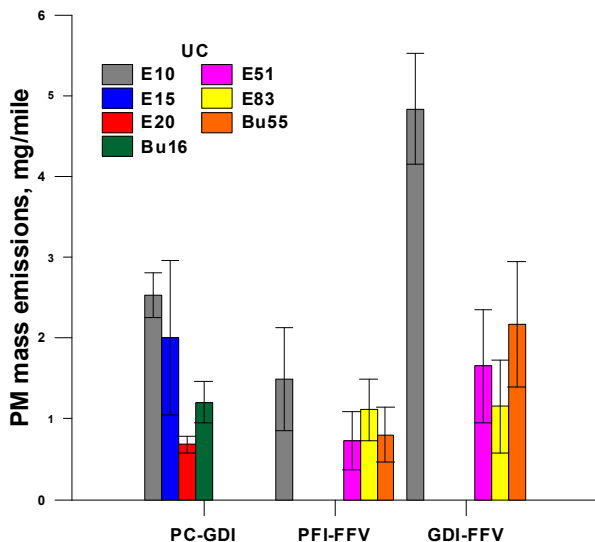

Table 1: PM Emissions on Alcohol-Blended Fuels

More than 100 PAH compounds were identified and quantified in both the gas- and particle-phase exhaust PM for all vehicle/fuel combinations over the FTP test cycle, including non-substituted PAHs, methyl- and ethyl-substituted PAHs, biphenyls, and oxygenated PAHs. Also, the GDI-FFV showed higher levels of total PAH emissions, compared to the other two vehicles, with the higher alcohol blends showing lower total PAH emissions than E10.

The oxidative potential, measured with the DTT assay, did not show any strong trends for the different alcohol fuels tested on both GDI and PFI vehicles. The DTT activity rates of all higher ethanol blends were below the blank/background samples for both the particle- and vapor-phase PM.

Benefits

The outcome of this study provided important information about the potential impacts of mid-level and high-level ethanol and iso-butanol blends on emissions and air quality during the near and medium term implementations of renewable fuel regulations. In addition, the test results are helpful in assessing the health consequences of population exposure to GDI vehicles in Southern California.

Project Costs

The project cost of \$175,000 was funded by the SCAQMD. This project was conducted in conjunction with a testing program primarily funded by a \$1,200,000 grant from the California Energy Commission to evaluate criteria and other regulated emissions from ethanol- and other alcohol-fueled vehicles.

Commercialization and Applications

In summary, the data from this study confirm that vehicles with direct injection fueling are exhibiting higher PM mass, number and soot emissions compared to PFI vehicles. The addition of higher ethanol blends results in lower particulate emissions for both engine technologies. This result is important since GDI vehicles are becoming more prevalent in the U.S. market and it is expected that they will eventually dominate the market over the conventional PFI vehicles.

The use of ethanol appears to be beneficial for substantially reducing PM mass emissions from GDI vehicles. Our findings show that GDI vehicles produce more toxic and potentially carcinogenic compounds in the tailpipe, such as those of PAHs, compared to PFI vehicles. The application of ethanol fuels, on the other hand, is capable of reducing most PAH compounds in the tailpipe. Overall, this study did not show any redox activity in both GDI and PFI exhaust, with the results being largely inconclusive regarding the health effects impact from current technology GDI and PFI vehicles on alcohol fuels.

Looking ahead, the results suggest that further testing is necessary utilizing next-generation GDI vehicles equipped with either wall-guided or spray-guided architectures on ethanol blends. More importantly, a more comprehensive investigation is necessary on real-world driving emissions using portable emission measurement systems (PEMS).

Develop Quantitative Cellular Assays to Understand the Chemical Basis of Air Pollutant Toxicity

Contractor

University of California Los Angeles (UCLA)

Cosponsors

SCAQMD

UC Riverside (UCR)/College of Engineering-Center for Environmental Research & Technology (CE-CERT)

Project Officer

Dr. Jean Ospital/Dr. Jo Kay Ghosh

Background

Regulatory efforts are focused on reduction of emissions of motor vehicles, including diesel-fueled vehicles involved with goods movement in Southern California. These reductions are aimed at meeting ambient air quality standards, including for PM10 and PM2.5, as well as reducing exposure to toxic air contaminants. As lower-emitting technologies are deployed and particle emissions go down, however, a question remains as to the toxicity of the remaining emissions. Although advanced technologies are very effective at lowering the mass of emissions, there are concerns that other substances such as volatile and semi-volatile organic compounds may be emitted that have potential adverse health effects.

Project Objective

The University of California Los Angeles (UCLA) proposed to develop a biological mechanism-based analytical procedure to characterize the toxicity of air pollutants. UCLA would work with UCR/CE-CERT to collect a large quantity of diesel exhaust, including both particulate and vapor phase, from a well-characterized engine using low-sulfur fuel as the standard. Quantitative dose response toxicity assays could then be conducted with, for example, emissions from advanced-technology engines to compare the results from assays using the standard diesel emissions. The project would also build upon the toxicity assays developed under the auspices of the Southern California Particle Center, which was sponsored by the U.S. EPA.

Technology Description

The assays target specific biochemical pathways and proteins that are thought to be involved in the

toxicity of pollutants. The pathways include inflammation, cellular oxidation potential and chemical reactions with cellular proteins. Specific chemical assays were used, as well as specific macrophage cell lines that had been used in previous air pollution toxicity studies. A standard protocol was also developed that was applied to collect pollutant samples. The overall response by the cell or the organism will reflect the “balance” between the two opposing responses. Investigators postulated that redox active metals in the particle phase are the major factors in inflammation and volatile organic electrophiles the major factor in adaptation.

Status

This project was done in two phases. The first phase was to conduct development and initial application of the toxicity assays. The second phase was to further develop and apply the toxicity assays to both particulate and vapor phase pollutant samples. This study is now complete.

The project was supposed to include fractionation of a large-scale diesel exhaust particle (DEP) sample coming from Japan. Because it wasn't timely provided during the scope of the project, UCLA was only able to begin some protocol development utilizing a sequential of extraction with the solvent mixtures and dominant chemical species extracted.

Results

Ambient air samples (PM2.5 and semi-volatile organic species) from Commerce (CM), Long Beach (LB) and San Bernardino (SB) were analyzed chemically with the DTT prooxidant and GAPDH electrophile assays and biologically for concentration-dependent effects on inflammation and adaptation, measured by induction of tumor necrosis factor alphas (TNFa) and hemeoxygenase-1 (HO-1), respectively, in a macrophage cell line. Seasonal differences were observed with winter PM2.5 samples from CM and LB containing significantly higher prooxidant content than the corresponding summer samples. Prooxidants were mostly in the particle phase (70-80%) and electrophiles were mostly (80-95%) in the vapor or the volatile organic phase in all samples. Biological analyses of summer PM2.5 samples reflected their

reactive chemical content with the SB sample the most proinflammatory. Analysis of the corresponding vapor samples showed the SB sample, with its highest electrophile content, to be the most potent in inducing adaptation. Aside from the regional and seasonal differences these quantitative analyses demonstrated, the chemical and biological results also pointed out the important contributions the volatile organic species in the ambient air provide to the overall biological effects of the ambient aerosol. The PM_{2.5} samples are proinflammatory; when examined separately from the vapor phase, they induce an inflammatory response, whereas the vapor phase, with its high electrophile content is pro-adaptive, inducing expression of proteins that suppress inflammation. Then when the vapor and particle effects are examined together, the proinflammatory effects of PM_{2.5} are reduced by the semi-volatile organic components.

Emission samples from biodiesel-fueled engines and cooking oil smoke samples from CE-CERT were also subjected to these analyses. However, as quantities limited the biological analyses to single concentration instead of three, comparisons between chemical and biological analyses were performed on separate samples at a fixed concentration and the data analyzed by correlation analysis. In general, the results agreed with those found in the three-community study above, in that the particle phase contained prooxidants and the vapor phase contained the electrophiles.

A correlation analysis of assay results and chemical data from CE-CERT was then performed to test the notions that the inflammatory response was related to prooxidant activity and that the adaptive response was reflective of the chemical data linked to organic electrophiles. For the particle samples, the inflammatory TNF α response and prooxidant effect were highly correlated ($p < .04$) and the prooxidant content correlated with redox active metal content ($p < .011$) consistent with the notion of metal-based prooxidant action on the inflammatory response. The electrophile content of the vapor samples was too low for measurement, but prooxidant content was measureable. Analyses of these samples showed a high correlation of the adaptive response with the prooxidant activity ($p < .014$) which, in turn correlated with the water-soluble organic content ($p < .04$). The objective of the study generating these samples was to compare the emissions for their potential toxicity and the results obtained here show the decreasing order to be ULSD > waste cooking oil \geq soy > animal fat methyl esters.

The cooking oil smoke-based results were qualitatively different from the biodiesel, reflecting differences in chemical composition; the adaptive response was dominant for the particles with a high correlation with prooxidant content ($p < .013$). Vapor phase sample adaptive activity did not correlate with either prooxidant or electrophile content.

The objective of the study generating these samples was to compare the effectiveness of three different types of filter systems in removing the toxic components of cooking oil smoke. The results indicate the decreasing order of toxicity to be baseline > Streivor > Innovatech > ES.

Benefits

The project helped to address questions such as which specific chemicals in pollutant samples are associated with cellular toxicity, assess the relative effects of particulate versus vapor phase of emissions, and compare toxic responses of emissions from different fuel types. The results would help form the scientific basis for quantifying how reducing emissions and promoting alternative technologies may improve public health. It helped understanding of the linkage between sources, chemical composition, and toxicity of emissions from motor vehicles, and thus how to assess strategies to protect the public from exposure to motor vehicle emissions.

Project Costs

For Phase 1 the SCAQMD provided \$368,457, with UCR/CE-CERT providing in-kind cost-share totaling \$60,609. For Phase 2 the SCAQMD provided \$319,553. Total project costs were \$748,619.

Commercialization and Applications

The results clearly demonstrate the advantages of quantitative chemical and biological analyses in the evaluation of air pollution toxicology. Furthermore, they show that such assays need not be for specific chemical species as much as they need to assay biologically relevant chemical reactivities together with biological responses. Investigators believe that the four relatively simple procedures for prooxidant and electrophile content and for inflammatory and adaptive responses, together with consistent collection procedures, will provide regulators with useful quantitative data in determining the conditions for adverse health associated with aerosol generation and approaches to its amelioration.

Study Of Oxidative Stress In Relation To Particulate Air Pollution Exposures In Elderly

Contractor

University of California Irvine

Cosponsors

SCAQMD
BP Group

Project Officer

Dr. Jean Ospital/Dr. Jo Kay Ghosh

Background

Ambient particulate matter (PM), specifically PM_{2.5} and PM₁₀, has been associated with increases in cardiovascular and respiratory hospitalization and mortality in many epidemiologic time series studies. However, exposure error from the use of PM_{2.5} and PM₁₀ has likely produced underestimates of PM effects because numerous toxic particle components are not accurately reflected by total mass (Ayres 2008). Furthermore, particle oxidative potential can be independent of mass, because a large fraction of PM mass is biologically inactive, while a temporally and spatially variable smaller fraction has the potential to induce oxidative stress. Oxidative stress is a key effect of air pollutants that is believed to be one of the major pathophysiological mechanisms responsible for the observed morbidity and mortality associations. Specifically, many experimental studies suggest that increased airway inflammation occurs through oxidative stress, which follows exposure to products of fossil fuel combustion, including chemicals with oxidative potential. However, there is little epidemiologic data on relations between such chemical components in PM air pollution including polycyclic aromatic hydrocarbons (PAH) and airway oxidative stress. These issues are important to assess given the multipollutant nature of PM. This has considerable importance to protecting public health since effect estimates from population studies may have underestimated effects by lumping air pollutant components with

different toxicities and different target organs into one surrogate exposure such as PM_{2.5}.

Project Objective

We examined relations of air pollution exposures to airway and systemic biomarkers of oxidative stress in a cohort panel of elderly subjects living in the Los Angeles air basin. This was accomplished with 12 weekly measurements of air pollutants and other cardiovascular and respiratory outcomes in a panel study funded by the National Institutes of Health (NIH, NIEHS, R01-ES12243-06). We collected exhaled breath condensates and measured biomarkers of airway oxidative stress and related them to air pollutant exposures. Air pollutants included size-fractionated PM, which was measured under the NIH funding. The biomarkers were assayed in the exhaled breath condensates and included malondialdehyde (a biomarker of lipid peroxidation) measured by fluorescent HPLC. The NIH study provided additional comparison data on airway inflammation, systemic oxidative stress and inflammation in the blood.

Technology Description

We conducted a cohort panel study involving 97 elderly subjects living in the Los Angeles metropolitan area. Airway and circulating biomarkers of oxidative stress and inflammation were measured weekly over 12 weeks and included, exhaled breath condensate malondialdehyde (EBC MDA), fractional exhaled nitric oxide (FeNO), plasma oxidized low-density lipoprotein (oxLDL), and plasma interleukin-6 (IL-6). Exposures included 7-day personal nitrogen oxides (NO_x), daily criteria-pollutant data, five-day average PM measured in three size-fractions and characterized by chemical components including transition metals, and *in vitro* PM oxidative potential (dithiothreitol and macrophage reactive oxygen species). Associations between biomarkers and pollutants were assessed using linear mixed effects regression models.

Status

This project was completed successfully in August 2016. The final report with complete technical details is submitted and on file at SCAQMD.

Results

We found significant positive associations of airway oxidative stress and inflammation with traffic-related air pollutants, ultrafine particles < 0.18 µm in aerodynamic diameter, and transition metals. Results for the airway biomarker of oxidative stress (EBC MDA) are shown in Figure 1.

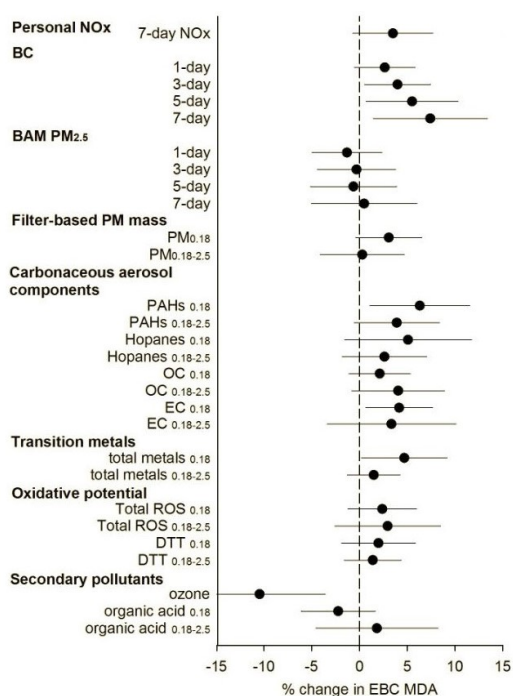

Figure 1. Percent Change (mean and 95 % confidence intervals) in airway inflammatory biomarkers EBC MDA (A) and airway oxidative stress biomarker FeNO (B) with a one interquartile range increase of ambient and personal air pollutants. Exposures were averaged across 5 days except as specified. BC: black carbon; CO: carbon monoxide; DTT: dithiothreitol; EBC MDA: malondialdehyde in exhaled breath condensate; EC: elemental carbon; FeNO: exhaled nitric oxide; NO_x: nitrogen oxides; OC: organic carbon; PAHs: polycyclic aromatic hydrocarbons; ROS: reactive oxygen species. From Zhang et al. Environ Res, 2016;150:306-319

Positive but nonsignificant associations were observed with markers of PM oxidative potential. The strongest associations were observed among PM variables in the ultrafine range. It was estimated that an interquartile increase in 5-day average ultrafine polycyclic aromatic hydrocarbons was associated with a 6.3% (95%

CI: 1.1%, 11.6%) increase in EBC MDA and 6.7% (95% CI: 3.4%, 10.2%) increase in FeNO. In addition, positive but nonsignificant associations were observed between oxLDL and traffic-related pollutants, ultrafine particles and transition metals while plasma IL-6 was positively associated with 1-day average traffic-related pollutants.

Benefits

This study adds to mounting evidence that exposure to prooxidant particle components from fossil fuel combustion sources such as PAH result in oxidative stress and inflammation. The extensive chemical characterization of air pollutant exposures in the present study enabled a comprehensive assessment of airway oxidative stress responses to different air pollutant components. These results were coherent with results from the parent NIH-funded parent study showing other adverse pathophysiological responses, including increased systemic inflammation and microvascular endothelial dysfunction. Results of this research has contributed to knowledge needed to control multipollutant exposures most likely to adversely impact the public's health because we addressed questions about which chemical components and sources of air pollution have the greatest potential for toxicity in people. Findings contribute to regulatory decisions aimed at protecting sensitive populations because putative causal constituents of PM are likely not well-represented by PM_{2.5} alone.

Project Costs

SCAQMD cost-shared this from the Clean Fuels Fund in the amount of \$159,974. The BP Group contributed \$216,394, in keeping with the ongoing terms of a 2005 settlement agreement. Total project costs were \$376,368.

Commercialization and Applications

This is an epidemiologic study using existing laboratory technology. The methods used can and should be applied to other projects with similar goals of assessing the health impacts of air pollution in susceptible populations. The results can be applied to the decision-making process on whether certain alternative fuel technologies should be developed and deployed.

Appendix D

Project Ranking

[This Page Intentionally Left Blank]

Project Ranking

For each of the core technologies discussed earlier in this report, staff considers numerous factors that influence the proposed allocation of funds, ranging from overall Environment & Health Benefits, Technology Maturity and Compatibility, and Cost, summarized in the proposed ranking system.

Within the broad factors included above, staff has included sub-factors for each specific type of project that may be considered, as summarized below:

Environment and Health

Criteria Pollutant Emission Reduction potential continues to receive the highest priority for projects that facilitate the NO_x reduction goals outlined in the 2016 AQMP. Technologies that provide co-benefits of Greenhouse Gas and Petroleum Reduction are also weighted favorably, considering the Clean Fuels Program is able to leverage funds available through several state and federal programs, as well as overall health benefits in reducing exposure to Ozone and PM_{2.5}, especially along disadvantaged communities.

Technology Maturity & Compatibility

Numerous approaches have been used to evaluate technology maturity and risk that include an evaluation of potential uncertainty in real world operations. This approach can include numerous weighting factors based on assessed importance of a particular technology. Some key metrics that can be considered include Infrastructure Constructability that would evaluate the potential of fuel or energy for the technology and readiness of associated infrastructure, Technology Readiness that includes not only the research and development of the technology, but potential larger scale deployments that consider near-term implementation duty and operational compatibility for the end users. These combined factors can provide an assessment for market readiness of the technology.

Cost/Incentives

The long-term costs and performance of advanced technologies are highly uncertain, considering continued development of these technologies is likely to involve unforeseen changes in basic design and materials. Additionally, economic sustainability – or market driven – implementation of these technologies is another key factor for the technology research, development, demonstration and deployment projects. Therefore, in an effort to accelerate the demonstration and deployment, especially some pre-commercialization technologies, incentive programs such as those available from local, state and federal programs are key, but may be underfunded for larger scale deployments. As a part of the 2016 AQMP, staff has also included the Draft Financial Incentives Funding Action Plan to address the funding necessary for full implementation of the control measures included.

Staff has proposed a simplified approach to ranking the core technologies, especially some of the specific platforms and technologies discussed in the draft plan and annual report. The rankings below take into account experience with implementing the Clean Fuels Program for numerous years, as well as understanding the current development and deployment state of the technologies and associated infrastructure, and are based on the following “Consumer Reports” type approach:

- Excellent ● Good ○ Satisfactory ● Poor ● Unacceptable

The table below summarizes staff ranking of the potential projects anticipated in the draft plan, and it is noted that technology developers, suppliers, and other experts may differ in their approach to ranking these projects. For example, staff ranks Electric/Hybrid Technologies and Infrastructure as Excellent or Good for Criteria Pollutant and GHG/Petroleum Reduction, but Poor to Good for Technology Maturity & Compatibility, and Satisfactory to Unacceptable for Costs and Incentives to affect large

scale deployment. It is further noted that the Clean Fuels Fund’s primary focus remains on-road vehicles and fuels, and funds for off-road and stationary sources are limited.

This approach has been reviewed with the Clean Fuels and Technology Advancement Advisory Groups, as well as the Governing Board.

Technologies & Proposed Solutions	Environment & Health			Technology Maturity & Compatibility				Cost	
	Emissions Reduction	GHG/Petroleum Reduction	Health Benefits	Infrastructure Constructability	Technology Readiness	Near-Term Implementation/Duty Cycle Fulfillment Capability	Operations Compatibility	Relative Cost & Economic Sustainability	Incentives Available
Electric/Hybrid Technologies & Infrastructure									
Plug-In Hybrid Heavy-Duty Trucks with Zero-Emission Range	●	○	●	●	○	●	●	●	●
Heavy-Duty Zero-Emission Trucks	●	●	●	●	●	●	○	●	●
Medium-Duty Trucks	●	●	●	●	○	●	●	●	●
Medium- and Heavy-Duty Buses	●	●	●	●	○	●	○	●	●
Light-Duty Vehicles	●	●	●	●	●	●	●	●	●
Infrastructure	-	-	-	●	●	●	●	○	●
Hydrogen & Fuel Cell Technologies & Infrastructure									
Heavy-Duty Trucks	●	●	●	○	●	●	●	●	●
Heavy-Duty Buses	●	●	●	○	●	●	●	●	●
Off-road – Locomotive/Marine	●	●	●	○	●	●	●	●	●
Light-Duty Vehicles	●	●	●	○	●	○	○	○	●
Infrastructure – Production, Dispensing, Certification	-	-	-	○	○	●	●	●	●
Engine Systems									
Ultra-Low emissions Heavy-Duty Engines	●	●	●	●	○	○	●	●	○
Alternative Fuel Medium- and Heavy-Duty Vehicles	●	●	●	●	●	●	●	●	○
Off-Road Applications	●	●	●	●	●	●	●	●	○
Fueling Infrastructure & Deployment									
Production of Renewable Natural Gas – Biowaste/Feedstock	●	●	●	●	●	●	●	○	○
Synthesis Gas to Renewable Natural Gas	●	●	●	●	●	●	●	○	○
Expansion of Infrastructure/Stations/Equipment/RNG Transition	●	●	●	●	●	●	●	●	○
Stationary Clean Fuel Technologies									
Low-Emission Stationary & Control Technologies	●	●	●	●	○	○	●	○	○
Renewable Fuels for Stationary Technologies	○	●	●	●	○	○	○	○	○
Vehicle-to-Grid or Vehicle-to-Building/Storage	●	●	●	○	○	●	○	○	●
Emission Control Technologies									
Alternative/Renewable Liquid Fuels	●	●	●	●	○	○	●	●	○
Advanced Aftertreatment Technologies	●	○	●	○	○	●	●	●	○
Lower-Emitting Lubricant Technologies	○	○	●	-	●	●	●	●	○
<p>● Excellent ● Good ○ Satisfactory ● Poor ● Unacceptable</p>									

Appendix E

List of Acronyms

[This Page Intentionally Left Blank]

LIST OF ACRONYMS

AB—Assembly Bill	DGE—diesel gallon equivalents
AC—absorption chiller	DF—deterioration factor
ADA—American with Disabilities Act	DME—dimethyl ether
AER—all-electric range	DMS—Division of Measurement Standards
AFRC—air/fuel ratio control	DMV—Department of Motor Vehicles
AFVs—Alternative Fuel Vehicles	DOC—diesel oxidation catalysts
APCD—Air Pollution Control District	DOE—Department of Energy
AQMD—Air Quality Management District	DOT—Department of Transportation
AQMP—Air Quality Management Plan	DPF—diesel particulate filters
ARB—Air Resources Board	DRC—Desert Resource Center
ARRA—American Recovery & Reinvestment Act	DRI—Desert Research Institute
AWMA—Air & Waste Management Association	ECM—emission control monitoring
BACT—Best Available Control Technology	EDTA—Electric Drive Transportation Association
BET—battery electric truck	EGR—exhaust gas recirculation
BEV—battery electric vehicle	EIN—Energy Independence Now
BSNO _x —brake specific NO _x	EPRI—Electric Power Research Institute
BMS—battery management system	E-rEV—extended-range electric vehicles
CAAP—Clean Air Action Plan	ESD—emergency shut down
CAFR—Comprehensive Annual Financial Report	EV—electric vehicle
CaFCP—California Fuel Cell Partnership	FCV—fuel cell vehicle
CARB—California Air Resources Board	FTA—Federal Transit Administration
CATI—Clean Air Technology Initiative	FTP—federal test procedures
CCF—California Clean Fuels	g/bhp-hr—grams per brake horsepower per hour
CCHP—combined cooling, heat and power	GC/MS—gas chromatography/mass spectrometry
CDFA/DMS—California Department of Food & Agriculture/Division of Measurement Standards	GCW—gross combination weight
CEC—California Energy Commission	GDI—gasoline direct injection
CE-CERT—College of Engineering – Center for Environmental Research and Technology	GGE—gasoline gallon equivalents
CEMS—continuous emission monitoring system	GGRF—Greenhouse Gas Reduction Relief Fund
CEQA—The California Environmental Quality Act	GHG—Greenhouse Gas
CFCI—Clean Fuel Connection, Inc.	GNA—Gladstein, Neandross & Associates, LLC
CFD—computational fluid dynamic	GTL—gas to liquid
CHBC—California Hydrogen Business Council	H&SC—California Health and Safety Code
CNG—compressed natural gas	HCCI—Homogeneous Charge Combustion Ignition
CNGVP—California Natural Gas Vehicle Partnership	HCNG—hydrogen-compressed natural gas (blend)
CO ₂ —carbon dioxide	HDDT—highway dynamometer driving schedule
CO—carbon monoxide	HD-FTP—Heavy-Duty Federal Test Procedure
ComZEV—Commercial Zero-Emission Vehicle	HDV—heavy-duty vehicle
CPA—Certified Public Accountant	HEV—Hybrid electric vehicle
CPUC—California Public Utilities Commission	HOA—Homeowners Association
CRDS—cavity ring-down spectroscopy	HQSA—hydrogen quality sampling adapter
CRT—continuously regenerating technology	HPDI—High Pressure Diesel Injection
CVAG—Coachella Valley Association of Governments	HPLC—high-performance liquid chromatography
CY—calendar year	HT—high throughput
DC—direct connection	HTFCs—high-temperature fuel cells
DCM—dichloromethane	H2NIP—Hydrogen Network Investment Plan
DEG—diesel equivalent gallons	HTPH—high throughput pretreatment and enzymatic hydrolysis
	HyPPO—Hydrogen Progress, Priorities and Opportunities report

LIST OF ACRONYMS (cont'd)

ICE—internal combustion engine	NSPS—New Source Performance Standard
ICEV—internal combustion engine vehicle	NSR—New Source Review
ICTC—Interstate Clean Transportation Corridor	NZ—near zero
IVOC—intermediate volatility organic compound	OBD—On-Board Diagnostics
kg—kilogram	OCS—overhead catenary system
LACMTA—Los Angeles County Metropolitan Transit Authority	OCTA—Orange County Transit Authority
LADWP—Los Angeles Department of Water and Power	OEHHA—Office of Environmental Health Hazard Assessment
LCFS—Low Carbon Fuel Standard	OEM—original equipment manufacturer
Li—lithium ion	PAH—polyaromatic hydrocarbons
LIMS—Laboratory Information Management System	PbA—lead acid
LLNL—Lawrence Livermore National Laboratory	PCM—powertrain control module
LNG—liquefied natural gas	PEMFC—proton exchange membrane fuel cell
LPG—liquefied petroleum gas or propane	PEMS—portable emissions measurement system
LSV—low-speed vehicle	PEV—plug-in electric vehicle
LUV—local-use vehicle	PHET—plug-in hybrid electric truck
LVP—low vapor pressure	PHEV—plug-in hybrid vehicle
MATES—Multiple Air Toxics Exposure Study	PM—particulate matter
MECA—Manufacturers of Emission Controls Association	PM2.5—particulate matter \leq 2.5 microns
MOA—Memorandum of Agreement	PM10—particulate matter \leq 10 microns
MPa—MegaPascal	POS—point of sale
MPFI—Multi-Port Fuel Injection	ppm—parts per million
MPG—miles per gallon	ppb—parts per billion
MSRC—Mobile Source Air Pollution Reduction Review Committee	PSI—Power Solutions International
MSW—municipal solid wastes	PTR-MS—proton transfer reaction-mass spectrometry
MY—model year	RDD&D (or RD3)—research, development, demonstration and deployment
MTA—Metropolitan Transportation Authority (Los Angeles County “Metro”)	REC—renewable energy certificates
NAAQS—National Ambient Air Quality Standards	RFP—Request for Proposal
NAFA—National Association of Fleet Administrators	RFS—renewable fuel standards
NFPA—National Fire Protection Association	RI—reactive intermediates
NCP—nonconformance penalty	RNG—renewable natural gas
NEV—neighborhood electric vehicles	RPS—Renewable Portfolio Standard
NextSTEPS—Next Sustainable Transportation Energy Pathways	RRC—rolling resistance co-efficient
NG/NGV—natural gas/natural gas vehicle	RTA—Riverside Transit Agency
NH3—ammonia	RTP/SCS—Regional Transportation Plan/Sustainable Communities Strategy
NHTSA—Natural Highway Traffic Safety Administration	SB—Senate Bill
NMHC—non-methane hydrocarbon	SCAB—South Coast Air Basin or “Basin”
NO—nitrogen monoxide	SCAQMD—South Coast Air Quality Management District
NO ₂ —nitrogen dioxide	SCE—Southern California Edison
NO + NO ₂ —nitrous oxide	SCR—selective catalytic reduction
NOPA—Notice of Proposed Award	SHR—Steam Hydrogasification Reaction
NO _x —oxides of nitrogen	SI—spark ignited
NRC—National Research Council	SI-EGR—spark-ignited, stoichiometric, cooled exhaust gas recirculation
NREL—National Renewables Energy Laboratory	SIP—State Implementation Plan

LIST OF ACRONYMS (cont'd)

SJVAPCD—San Joaquin Valley Air Pollution Control District
SOAs—secondary organic aerosols
SoCalGas—Southern California Gas Company (A Sempra Energy Utility)
SULEV—super ultra-low emission vehicle
SUV—Sports Utility Vehicle
TAO—Technology Advancement Office
TC—total carbon
TEMS—transportable emissions measurement system
THC—total hydrocarbons
TO—task order
tpd—tons per day
TRB—Transportation Research Board
TSI—Three Squares, Inc.
TWC—three-way catalyst
UCR—University of California Riverside
UCLA—University of California Los Angeles
UDDS—urban dynamometer driving schedule
 $\mu\text{g}/\text{m}^3$ —microgram per cubic meter
ULEV—ultra low emission vehicle
UPS—United Postal Service
U.S.—United States
U.S.EPA—United States Environmental Protection Agency
V2B—vehicle-to-building
V2G—vehicle-to-grid
VMT—vehicle miles traveled
VOC—volatile organic compounds
WVU—West Virginia University
ZECT—Zero Emission Cargo Transport
ZEV—zero emission vehicle



Technology Advancement Office
Leading the way to zero and near-zero emission technologies

Clean Fuels Program 2016 Annual Report and 2017 Plan Update

March 2017



South Coast Air Quality Management District
aqmd.gov

BACKGROUND

- Annual Report on Clean Fuels Program (HSC 40448.5.1)
- Technology Advancement Plan (Update) (HSC 40448.5)
- Draft 2017 Plan Update submitted to Technology Committee October 21, 2016
- Annual public hearing to approve Annual Report and adopt final Plan Update
- Submit to Legislature by March 31 every year

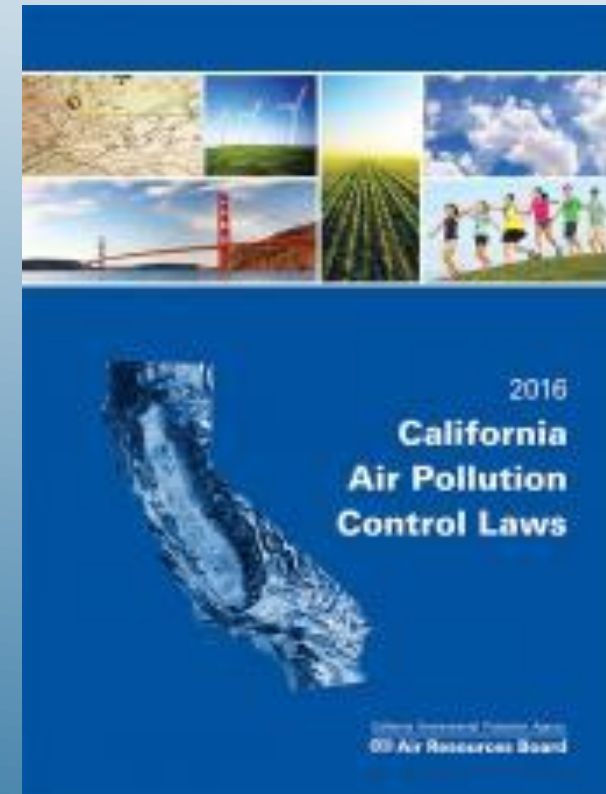

INPUT

- Advisory group meetings
 - September 2016 and January 2017
 - Technology Advancement Advisory Group
 - Clean Fuels Advisory Group
 - Invited technical experts
- Meetings with agencies, industry groups technology providers and other stakeholders
- Zero and near-zero emissions heavy-duty truck site visit and discussion with EPA, CARB, Ports (October 2016)
- Medium- and Heavy-Duty Innovators Roundtable (May 2016)



CLEAN FUELS PROGRAM CORE TECHNOLOGIES

- **Hydrogen/Fuel Cell Technologies and Infrastructure**
- **Electric/Hybrid Technologies and Infrastructure**
- **Engine Systems (ultra-low emission NG HDVs)**
- **Fueling Infrastructure and Deployment (NG/RNG)**
- Fuels/Emissions Studies
- Stationary Clean Fuel Technologies
- Emission Control Technologies
- Health Impacts Studies
- Technology Assessment/Transfer and Outreach



2016 – KEY FUNDING PARTNERS

Total = \$48.9M



CY 2016 ACCOMPLISHMENTS

- Contracts executed - 66
 - \$21.8 million from Clean Fuels Fund
 - \$198 million – total project costs
 - 1:9 leveraging (not typical*)
- Completed projects - 43
 - 32 research, development, demonstration and deployment projects
 - 11 technology assessment/transfer and outreach projects

Funding Distribution

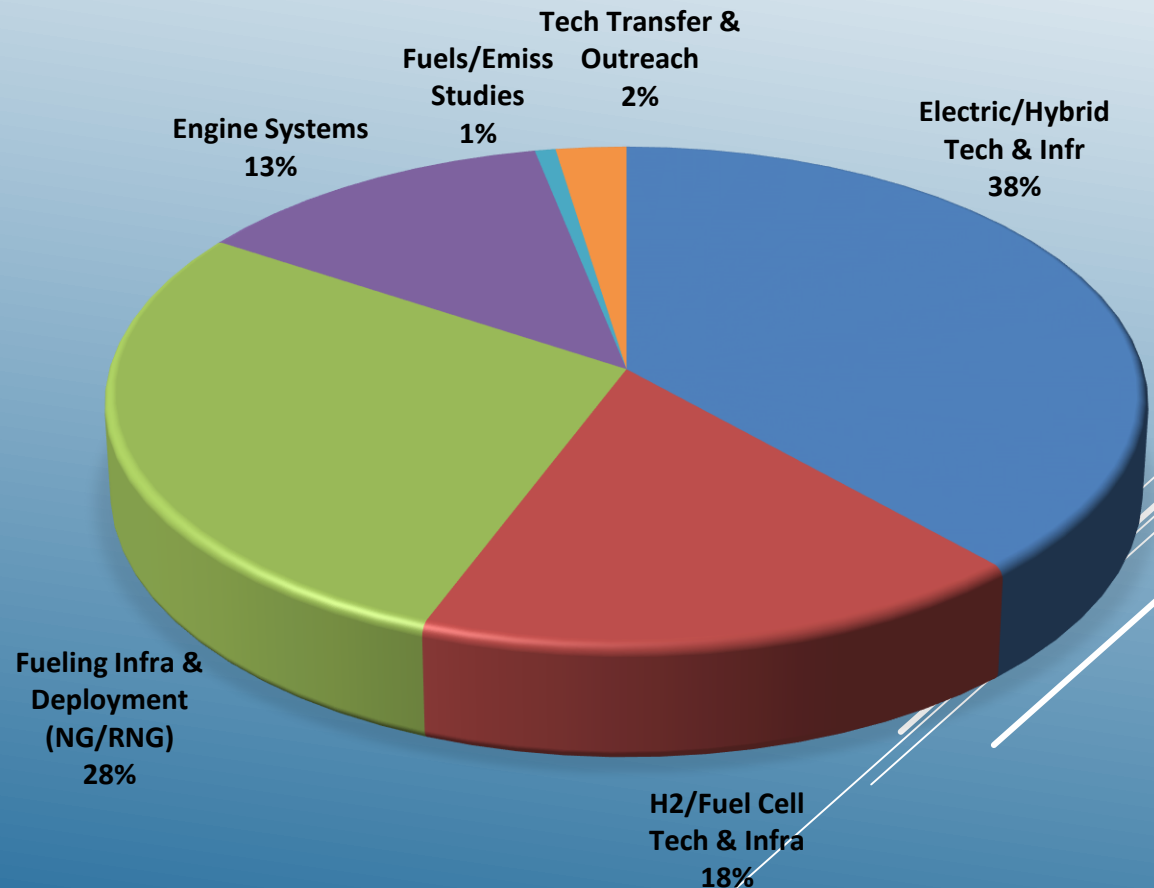

*Typical cost leveraging is \$3-\$4 per every Clean Fuels \$1



2016 KEY PROJECTS INITIATED

- Hydrogen/fuel cell technologies and infrastructure
 - ZECT II: Class 8 fuel cell range-extended electric drayage truck
 - Fuel cell extended-range powertrain for parcel delivery trucks
 - Fuel cell hybrid electric medium-duty trucks
- Electric/hybrid technology development and demonstrations
 - Zero Emission Drayage Truck Demonstration Project (BYD, Kenworth, Peterbilt and Volvo)



2016 KEY PROJECTS INITIATED (CONT'D)

- Engine systems
 - Ultra-low emission 12L natural gas engines
- Fueling Infrastructure and deployment (NG/RNG)
 - RNG production facilities & RNG vehicle demonstrations
 - Fueling station expansion adding NG for retail multi-fuel alternative fuel station
- Fuels/Emissions studies
 - Ozone & secondary aerosol formation
 - Opportunities/benefits of deploying next gen heavy-duty NG vehicles operating on RNG



KEY PROJECTS COMPLETED IN 2016

- Burbank hydrogen station (next step upgrade to current retail standard)
- Plug-in hybrid electric drive system for medium- and heavy-duty vehicles
- Ultra-low emission NG engine for on-road heavy-duty vehicles



DRAFT 2017 PLAN UPDATE

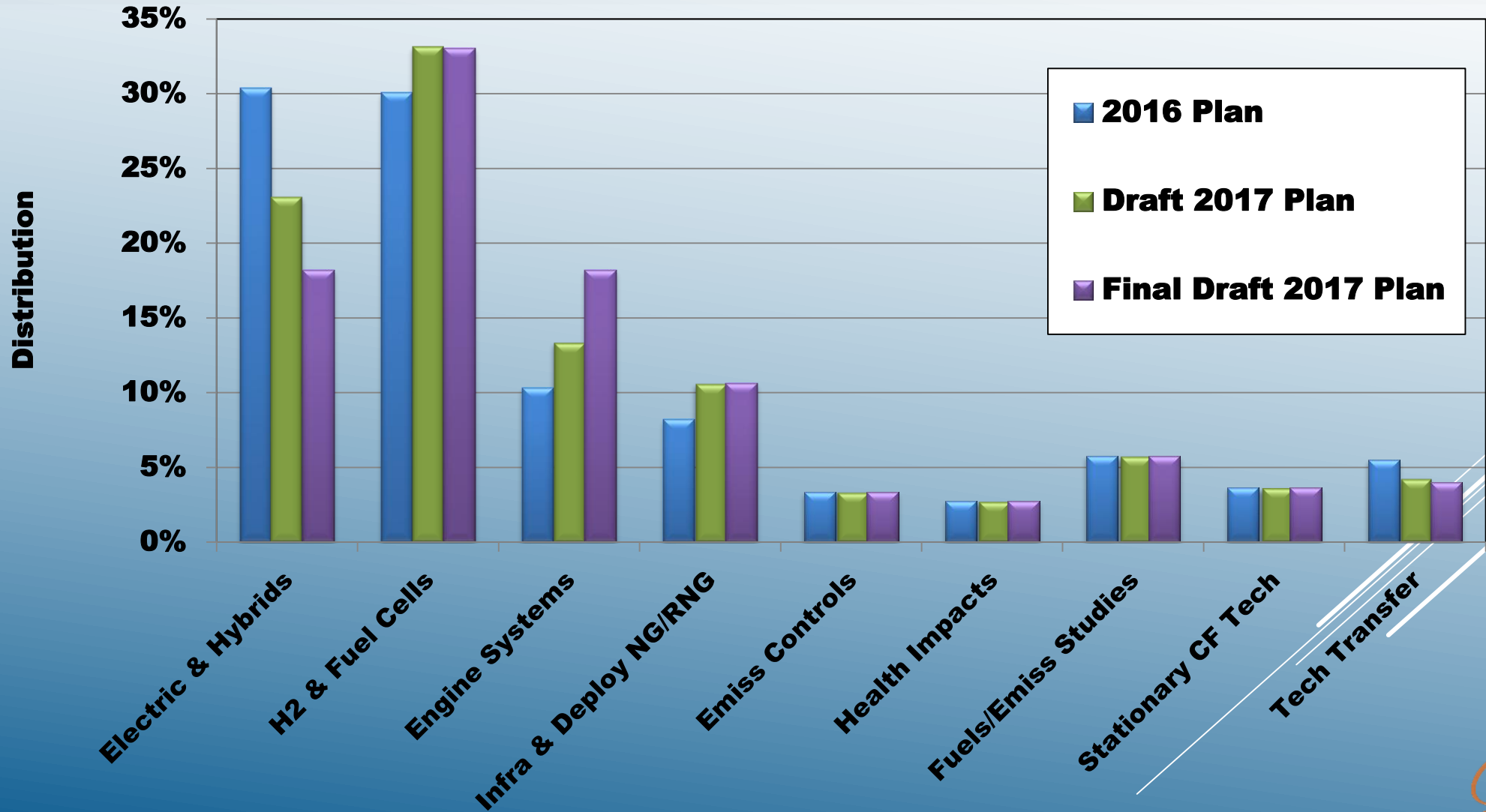

DRAFT 2017 PLAN UPDATE

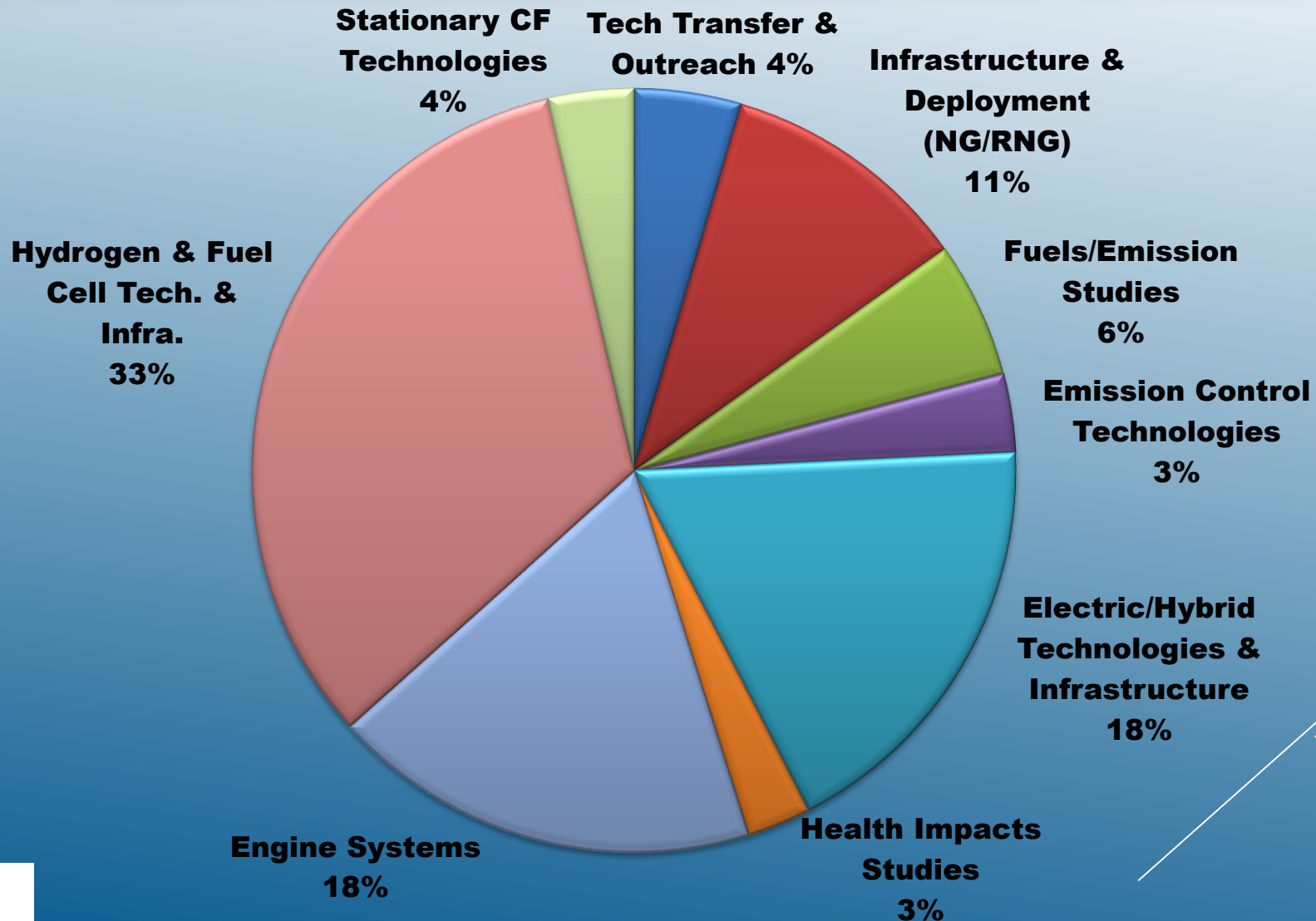

\$16.5M



PROPOSED DISTRIBUTION

	2016 Plan	Final Draft 2017 Plan
Electric/Hybrids Technologies & Infra.	30%	18%
H2/Fuel Cells Technologies & Infra.	30%	33%
Engine Systems	10%	18%
Fueling Infra. & Deployment (NG/RNG)	8%	11%
Emissions Control Technologies	3%	3%
Health Impacts Studies	3%	3%
Fuels & Emissions Studies	6%	6%
Stationary Clean Fuel Technologies	4%	4%
Tech Assessment/Transfer & Outreach	6%	4%
	100%	100%

ANNUAL REPORT & PLAN UPDATE DEVELOPMENT

- Technology Committee October 21, 2016
(Draft 2017 Plan Update)
- Advisory Group Review September 1, 2016
January 19, 2017
- Technology Committee February 17, 2017
- Board Approval March 3, 2017
- Due to State Legislature March 31, 2017

RECOMMENDED ACTIONS

- Approve Clean Fuels Program 2016 Annual Report
- Adopt Clean Fuels Program Plan Update for 2017
- Approve resolution finding no duplicate projects or programs funded by other state/local agencies
- Direct staff to forward documents to State Legislative Analyst by March 31, 2017