

1 **BEFORE THE HEARING BOARD OF THE**
2 **SOUTH COAST AIR QUALITY MANAGEMENT DISTRICT**

3 **In The Matter Of**

4 SOUTH COAST AIR QUALITY
5 MANAGEMENT DISTRICT,

6 Petitioner,

7 vs.

8 CHIQUITA CANYON, LLC a Delaware
9 Corporation,
[Facility ID No. 119219]

10 Respondent.

Case No. 6177-4

**EXHIBIT O TO DECLARATION OF
PATRICK SULLIVAN, BCES, CPP,
REPA**

Health and Safety Code § 41700, and
District Rules 402, 431.1, 3002, 203, 1150

Hearing Date: May 28, 2026

Hearing Time: 9:30 A.M.

Place: Hearing Board
South Coast Air Quality
Management District,
21865 Copley Drive
Diamond Bar, CA 91765

**SOURCE TEST REPORT FOR
2025 4TH QUARTER LEACHATE AND CONDENSATE
VAPOR SAMPLING AT THE
CHIQUITA CANYON LANDFILL
FACILITY ID: 119219**

Prepared For:

SCS Engineers – Chiquita Canyon Landfill
3900 Kilroy Airport Way, Suite 100
Long Beach, California 90806

For Submittal To:

South Coast Air Quality Management District
21865 Copley Drive
Diamond Bar, California 91765-4178

Prepared By:

Montrose Air Quality Services, LLC
1631 E. St. Andrew Pl.
Santa Ana, California 92705
(714) 279-6777

Pete San Juan

Test Date: **November 24, 2025**
Production Date: **December 24, 2025**
Document Number: **W002AS-061273-RT-8054**



CONFIDENTIALITY STATEMENT

Except as otherwise required by law or regulation, this information contained in this communication is intended exclusively for the individual or entity to which it is addressed. This communication may contain information that is proprietary, privileged or confidential or otherwise legally exempt from disclosure. If you are not the named addressee, you are not authorized to read, print, retain, copy, or disseminate this message or any part of it.

REVIEW AND CERTIFICATION

All work, calculations, and other activities and tasks performed and presented in this document were carried out by me or under my direction and supervision. I hereby certify that, to the best of my knowledge, Montrose operated in conformance with the requirements of the Montrose Quality Management System and ASTM D7036-04 during this test project.

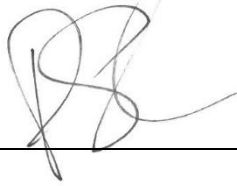
Signature:  _____ Date: 12/24/2025

Name: Pete SanJuan Title: Client Project Manager

I have reviewed, technically and editorially, details, calculations, results, conclusions, and other appropriate written materials contained herein. I hereby certify that, to the best of my knowledge, the presented material is authentic, accurate, and conforms to the requirements of the Montrose Quality Management System and ASTM D7036-04.

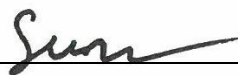
Signature:  _____ Date: 12/24/2025

Name: Surya Adhikari Title: Senior Reporting QC Specialist

TABLE OF CONTENTS

<u>SECTION</u>	<u>PAGE</u>
1.0 INTRODUCTION	5
2.0 FACILITY AND SOURCE INFORMATION	6
2.1 PROCESS EQUIPMENT INFORMATION	6
3.0 TEST INFORMATION AND METHODOLOGY	7
3.1 SCAQMD METHOD 1.1 – SAMPLING AND VELOCITY TRAVERSES FOR STATIONARY SOURCES.....	7
3.2 SCAQMD METHOD 2.1 – VELOCITY AND VOLUMETRIC FLOW RATE	8
3.3 SCAQMD METHOD 3.1 – GAS ANALYSIS FOR DRY MOLECULAR WEIGHT AND EXCESS AIR	8
3.4 SCAQMD METHOD 4.1 – DETERMINATION OF MOISTURE CONTENT IN STACK GASES	8
3.5 SCAQMD METHOD 307-91 – HYDROGEN SULFIDE AND REDUCED SULFUR COMPOUNDS.....	8
3.6 EPA METHOD TO-15 – VOLATILES AND HYDROCARBON COLLECTED IN SUMMA CANISTER.....	8
4.0 RESULTS	9

LIST OF APPENDICES

A TEST DATA.....	11
A.1 Sample Location Data	12
A.2 Velocity, Moisture and Flow Rate Data	21
A.3 Organics and Sulfur Field and Laboratory Data	39
A.4 Quality Assurance Data.....	78
B GENERAL EMISSIONS CALCULATIONS	89
C QUALITY ASSURANCE	92
C.1 Quality Assurance Program Summary	93
C.2 SCAQMD and STAC Certifications	99
C.3 Individual QI Certifications.....	102
C.4 Statement of No Conflict of Interest	106
D FACILITY PERMIT	108

LIST OF TABLES

3-1 TEST PROCEDURES.....	7
4-1 H ₂ S AND TOTAL REDUCED SULFUR RESULTS	9
4-2 TRACE ORGANICS SPECIES RESULTS.....	10

1.0 INTRODUCTION

Montrose Air Quality Services, LLC (MAQS) was contacted by SCS Engineers (SCS) to conduct quarterly sampling at various locations on the vapor ventilation system located at the Chiquita Canyon Landfill (Chiquita), in Castaic, California. Testing was conducted to comply with Condition 72 of the Modified Stipulated Order for Abatement (SOFA) issued to Chiquita by the South Coast Air Quality Management District (SCAQMD). The tests were conducted according to the test protocol (MAQS Document Number W002AS-056454-PP-1074) and source test protocol evaluation (S/T ID: P24228). The Montrose test team consisted of Pete San Juan, Allen Dusky, and Jose Iniguez. Pete San Juan was the on-site qualified individual for MAQS. MAQS qualifies as an independent testing laboratory under SCAQMD Rule 304 (no conflict of interest) and is certified by the SCAQMD to conduct testing for criteria pollutants according to District Methods.

Equipment and facility information is provided in Section 2.0. Source test information is detailed in Section 3.0. Test results are provided in Section 4.0. Supplemental information is contained in the Appendices.

2.0 FACILITY AND SOURCE INFORMATION

The facility address is:

Physical Address: Chiquita Canyon Landfill
29201 Henry Mayo Drive
Castaic, California 91384

Sampling of leachate and condensate vapors was conducted from the following locations:

- The tank vents or manifolds which are representative of a set of tanks;
- The header/manifold from each leachate tank farm or manifold including inlet to the Parnel Flare, inlet to the Zeeco Flare, inlet to the Hero FLare, Tank Farm #7B, Tank Farm Canyon D, Tank Farm 13, Flare Station Pre-H₂S treatment, and Flare Station Post-H₂S treatment. Testing was performed upstream of the piping connection to the LFG Collection and Conveyance System where landfill gas may affect results.

2.1 PROCESS EQUIPMENT INFORMATION

Vapors created from the volatilization of chemicals in the head space in the leachate tanks at tank farms , #7B, Canyon D, and #13 are transferred under vacuum through the wellhead and into the landfill gas collection system then to the flare station for combustion. The pressure and temperature of the vapors in the piping varies based on ambient temperatures during normal operation. The facility operates 24 hours per day. Photographs of the locations sampled are located in Appendix A.1.

3.0 TEST INFORMATION AND METHODOLOGY

The pollutants measured and test methodology are summarized in Table 3-1. Volume flow rate measurements were performed before the sample collection.

The field sampling procedures utilized during the test program are described below. The published reference methods provide greater detailed descriptions than in this section. The purpose of this section is to provide an overview of the sampling methods and any variations. The sampling procedures are based on SCAQMD and EPA Reference Methods.

**TABLE 3-1
 TEST PROCEDURES
 TEST PROGRAM OVERVIEW
 CHIQUITA CANYON LANDFILL
 LEACHATE AND CONDENSATE VAPOR SAMPLING**

Parameter	Sample Medium	Analytical Technique	Reference Method	Number of Replicates
Flow Rate/Temperature	Pitot Tube / TC	Differential Pressure	SCAQMD 2.1	1 for each location
Moisture	Wet Bulb/Dry Bulb	Psychrometric Chart	SCAQMD 4.1	1 for each location
H ₂ S and TRS	Summa Can	GC/SCD	SCAQMD 307-91	1 for each location
TO-15 (Rule 1150.1)	Summa Can	GC/MS	EPA TO-15	1 for each location

3.1 SCAQMD METHOD 1.1 – SAMPLING AND VELOCITY TRAVERSES FOR STATIONARY SOURCES

A preliminary source test site assessment was performed prior to the source test in order to determine applicable sample point traverse locations. The stack diameter, and the distance from sample ports to disturbances (bends, flanges, etc.), both upstream and downstream, were measured. This information is utilized to determine the minimum number of sampling points per traverse, and the distance from the inner stack wall to each sample point location. All sample locations were located according to the minimum requirements of SCAQMD Method 1.1. Additionally, this method considers cyclonic flow patterns and in-situ stratified pollutant concentrations. Cyclonic flow tests were performed at locations where flow was measurable.

3.2 SCAQMD METHOD 2.1 – VELOCITY AND VOLUMETRIC FLOW RATE

The velocity of the gas stream was determined by using an "S" type or standard pitot tube, a low flow electronic manometer, and type "K" thermocouple with a digital temperature measuring device. The calibrated pitot tube is connected to the calibrated electronic Air Data Multimeter (ADM) manometer and leak checked. A temperature and delta P is obtained at each traverse point, and a duct static pressure is measured and recorded. The dry volumetric flow rate is determined from the gas velocity data, stack pressure, stack gas moisture content, stack gas molecular weight, and cross-sectional area of duct.

3.3 SCAQMD METHOD 3.1 – GAS ANALYSIS FOR DRY MOLECULAR WEIGHT AND EXCESS AIR

Leachate and condensate vapor gases were analyzed by GC for O₂ and CO₂.

3.4 SCAQMD METHOD 4.1 – DETERMINATION OF MOISTURE CONTENT IN STACK GASES

Moisture was measured using a wet bulb/dry bulb and calculated with a psychrometric chart.

3.5 SCAQMD METHOD 307-91 – HYDROGEN SULFIDE AND REDUCED SULFUR COMPOUNDS

Samples for determination of hydrogen sulfide and speciated reduced sulfur compounds were collected in Summa canisters. The samples were analyzed by GC/SCD by AtmAA, Inc., in Calabasas, California, following SCAQMD Method 307-91 protocol. The samples are analyzed within 24 hours of sampling.

3.6 EPA METHOD TO-15 – VOLATILES AND HYDROCARBON COLLECTED IN SUMMA CANISTER

Samples were collected in glass silicate lined Summa canisters. The samples were analyzed by AtmAA Inc., located in Calabasas, California for volatile organics listed in SCAQMD Rule 1150.1 Table 1 list.

Sampling Procedure:

One summa can per location was filled with sample gas using an evacuated cylinder. The sampling probe was connected to the can with Teflon tubing. The samples were collected at a fixed point halfway into the sampling duct.

4.0 RESULTS

The emission results are presented in Tables 4-1 and 4-2. Site schematics are presented in Appendix A.1.

**TABLE 4-1
 H₂S AND TOTAL REDUCED SULFUR RESULTS
 CHIQUITA CANYON LANDFILL
 LEACHATE AND CONDENSATE VAPOR SAMPLING
 NOVEMBER 24, 2025**

Parameter/Units	Parnel	Zeeco	Hero	Tank Farm 7B	Canyon D	Tank Farm 13	Flare Station Pre-H2S	Flare Station Pre-H2s
O ₂ , %	7.25	8.83	7.25	8.27	21.36	21.30	4.83	5.35
CO ₂ , %	40.44	30.39	40.67	26.34	0.58	0.82	38.03	36.87
N ₂ , %	30.39	39.85	30.45	36.15	76.10	75.82	22.43	24.12
H ₂ O, %	3.67	5.68	4.10	1.05	0.83	0.87	2.68	2.72
Flow Rate, scfm	1,368	2,520	610	559	180	296	1,643	1,648
Temperature, °F	129	154	131	92	92	94	110	108
Sulfur Compounds								
H ₂ S, ppm	133	107	140	181	0.24	<0.08	244	27.7
Carbonyl Sulfide, ppm	<1.50	<1.00	<1.50	1.01	<0.08	<0.08	0.95	0.9
Methyl Mercaptan, ppm	258.00	82.7	303	24.30	0.35	0.28	82.1	37.5
Ethyl Mercaptan, ppm	3.18	1.53	3.60	0.40	<0.08	<0.08	1.22	<0.80
Dimethyl Sulfide, ppm	828.00	315	963	70.20	1.90	14.10	291	278
Carbon Disulfide, ppm	<1.50	<1.00	<1.50	<0.30	<0.08	<0.08	<1.00	<0.80
i-Propyl Mercaptan, ppm	2.22	1.03	2.38	2.910	<0.08	<0.08	2.71	1.69
t-Butyl Mercaptan, ppm	<1.50	<1.00	<1.50	<0.30	<0.08	<0.08	<1.00	<0.80
n-Propyl Mercaptan, ppm	11.30	4.58	12.6	1.06	<0.08	0.15	3.97	3.47
s-Butyl Mercaptan, ppm	10.80	3.78	12.1	3.39	<0.08	0.09	5.36	3.81
i-Butyl Mercaptan, ppm	<1.50	<1.00	<1.50	<0.30	<0.08	<0.08	<1.00	<0.80
Dimethyl Disulfide, ppm	7.51	1.99	7.22	<0.30	<0.08	<0.08	2.78	8.29
Tetrahydrothiophene, ppm	6.67	1.60	7.3	0.37	<0.08	0.09	2.22	1.71
Unidentified S Compounds, ppm	24.00	5.91	23.8	1.69	0.23	0.09	10.5	22.3
Total Sulfur Compounds:								
Total Sulfur, ppm	1,291.09	526.54	1,481.11	286.26	2.71	14.74	649.48	393.05

TABLE 4-2
TRACE ORGANICS SPECIES RESULTS
CHIQUITA CANYON LANDFILL
LEACHATE AND CONDENSATE VAPOR SAMPLING
NOVEMBER 24, 2025

Sample Location:	Parnel	Zeeco	Hero	Tank Farm 7B	Canyon D	Tank Farm 13	Flare Station Pre Pre-H ₂ S	Flare Station Post Post H ₂ S
Test No.:	1	1	1	1	1	1	1	1
Start Time:	7:30	7:30	8:10	8:45	9:20	9:20	10:00	10:00
Flow Rate, scfm:	1368	2520	610	559	180	296	1,643	1,648
Species	ppb	ppb	ppb	ppb	ppb	ppb	ppb	ppb
Hydrogen sulfide:	133,000	106,500	139,500	181,000	235	< 80	244,000	9,386
Benzene:	158,000	52,600	180,000	12,000	706	< 2,470	81,400	45,900
Benzyl Chloride:	< 4,500	< 4,500	< 4,500	< 45	< 45	< 45	< 4,500	< 4,500
Chlorobenzene:	< 4,500	< 4,500	< 4,500	< 40	< 40	< 40	< 4,500	< 4,500
Dichlorobenzenes*:	< 6,500	< 6,500	< 6,500	< 80.0	< 80	< 80	< 6,500	< 6,500
1,1-dichloroethane:	< 5,000	< 5,000	< 5,000	< 50	< 50	< 50	< 5,000	< 5,000
1,2-dichloroethane:	< 5,000	< 5,000	< 5,000	343	343	343	< 5,000	< 5,000
1,1-dichloroethylene:	< 5,000	< 5,000	< 5,000	< 50	< 50	< 50	< 5,000	< 5,000
Dichloromethane:	< 11,000	< 11,000	< 11,000	< 110	< 110	< 110	< 11,000	< 11,000
1,2-dibromoethane:	< 3,000	< 3,000	< 3,000	< 30	< 30	< 30	< 3,000	< 3,000
Perchloroethylene:	< 3,000	< 3,000	< 3,000	62.0	< 30	< 30	< 3,000	< 3,000
Carbon Tetrachloride:	< 4,000	< 4,000	< 4,000	< 60	< 60	< 60	< 4,000	< 4,000
Toluene:	13,750	5,460	14,900	2,130	227	266	12,700	7,240
1,1,1-trichloroethane:	< 4,000	< 4,000	< 4,000	< 35	< 35	< 35	< 4,000	< 4,000
Trichloroethene:	< 4,000	< 4,000	< 4,000	42.6	< 35	< 35	< 4,000	< 4,000
Chloroform:	< 4,000	< 4,000	< 4,000	< 40	< 40	< 40	< 4,000	< 4,000
Vinyl Chloride:	< 4,000	< 4,000	< 4,000	< 40	< 40	< 40	< 4,000	< 4,000
M+P-xylenes:	5,865	< 4,500	5,780	608	66.9	84.7	< 4,500	< 4,500
O-xylene:	< 4,500	< 4,500	< 4,500	159	< 45	< 45	< 4,500	< 4,500

< - indicates that the species was not detected in the sample above the analytical detection limit for this species.

The values reported is the detection limit for the species and the actual concentration is lower.

*Total amount containing meta, para, and ortho isomers.

APPENDIX A TEST DATA

Appendix A.1 Sample Location Data

METHOD 1 DATA SHEET INLET SAMPLE LOCATION

Client: SCS Field Services

Date: 11/24/25

Location: Chiquita Parnel Inlet

Performed By: SJ, AD, JI

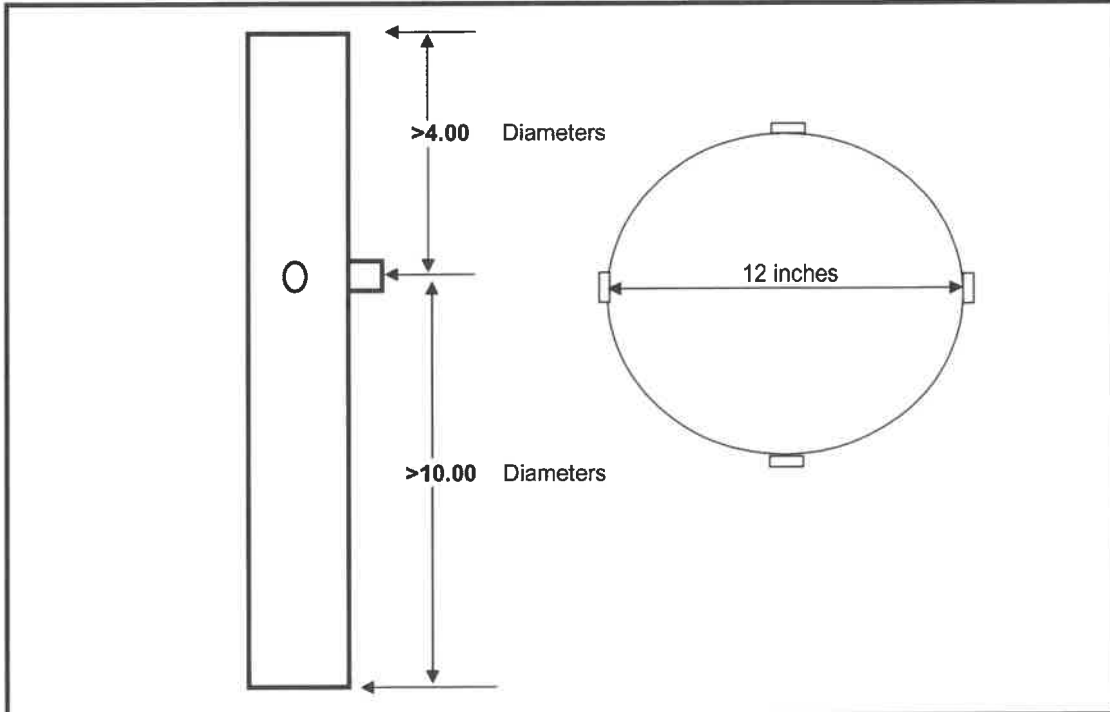

Diameter (inches)	12.00			
Upstream (inches)	120.00	Sample Point	% of Diameter	Dist from Wall (inches)
Downstream (inches)	48.00	1	4.4	0.5
Coupling (in.)	0.00	2	14.6	1.8
Stack Area (ft ²)	0.785	3	29.6	3.6
		4	70.4	8.4
		5	85.4	10.2
		6	95.6	11.5



METHOD 1 DATA SHEET INLET SAMPLE LOCATION

Client: SCS Field Services

Date: 11/24/25

Location: Chiquita Zeeco Flare Inlet

Performed By: SJ, AD, JI

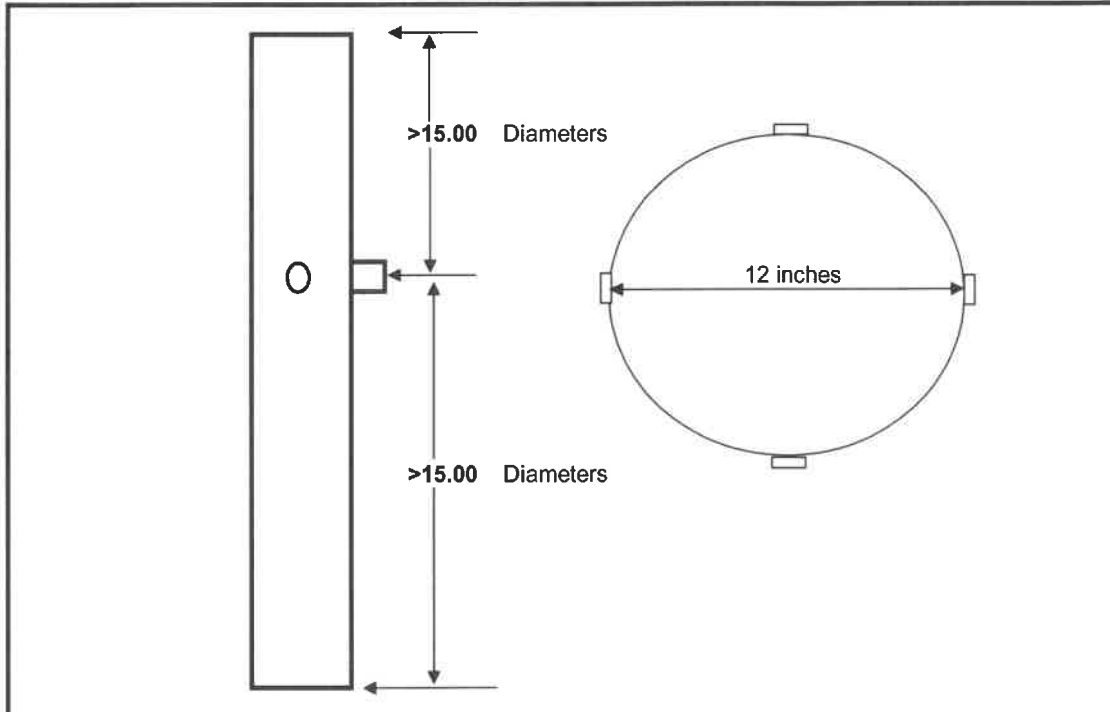

Diameter (inches)	12.00			
Upstream (inches)	180.00	Sample Point	% of Diameter	Dist from Wall (inches)
Downstream (inches)	180.00	1	4.4	0.5
Coupling (in.)	0.00	2	14.6	1.8
Stack Area (ft ²)	0.785	3	29.6	3.6
		4	70.4	8.4
		5	85.4	10.2
		6	95.6	11.5



METHOD 1 DATA SHEET INLET SAMPLE LOCATION

Client: SCS Field Services

Date: 11/24/25

Location: Hero

Performed By: SJ, AD, JI

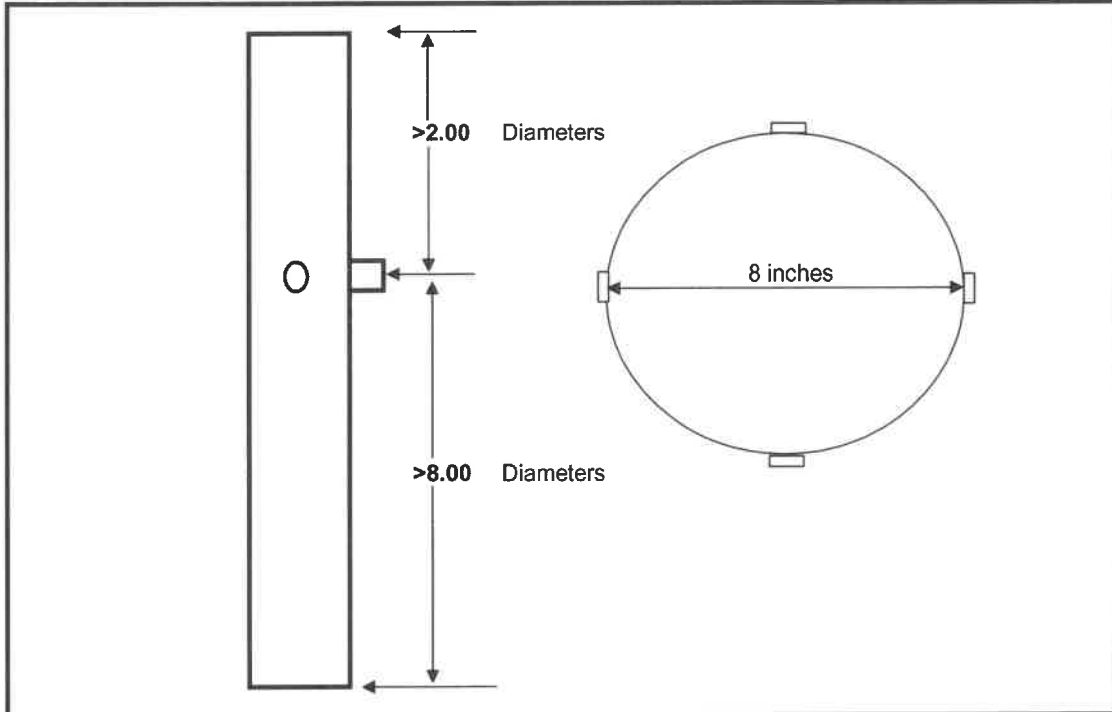

Diameter (inches)	8.00			
Upstream (inches)	64.00	Sample Point	% of Diameter	Dist from Wall (inches)
Downstream (inches)	16.00	1	4.4	0.5
Coupling (in.)	0.00	2	14.6	1.2
Stack Area (ft ²)	0.349	3	29.6	2.4
		4	70.4	5.6
		5	85.4	6.8
		6	95.6	5.5



METHOD 1 DATA SHEET INLET SAMPLE LOCATION

Client: SCS Field Services

Date: 11/24/25

Location: Chiquita TF 7B

Performed By: SJ, AD, JI

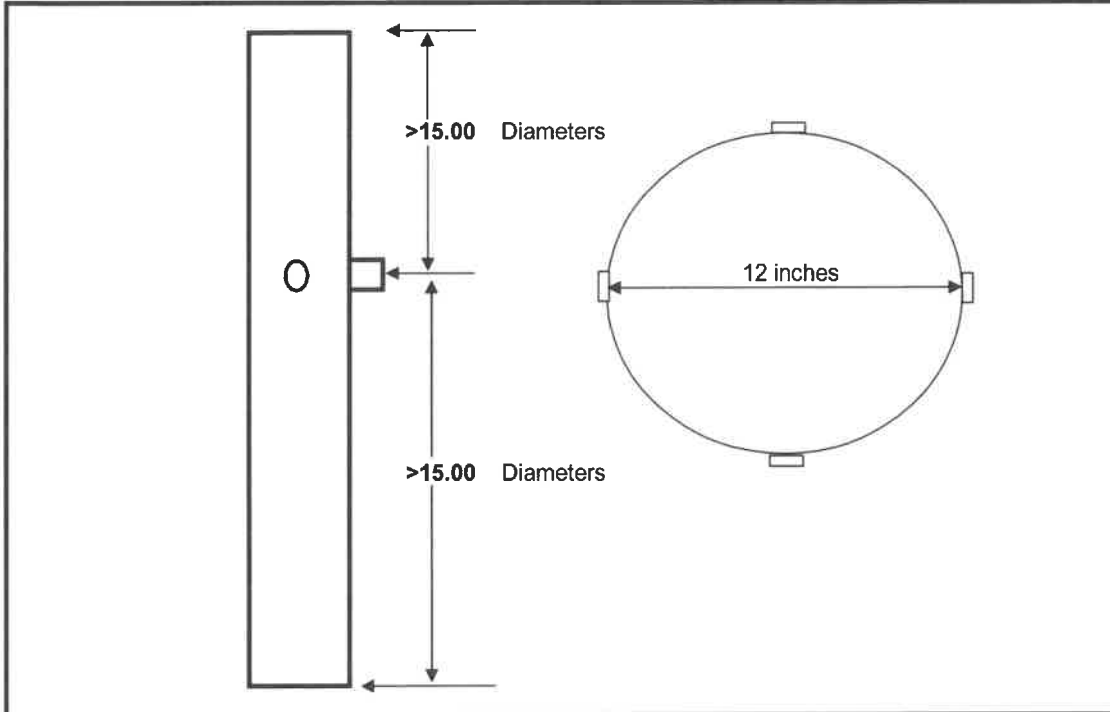

Diameter (inches)	<u>12.00</u>			
Upstream (inches)	<u>180.00</u>	Sample Point	% of Diameter	Dist from Wall (inches)
Downstream (inches)	<u>180.00</u>	1	4.4	0.5
Coupling (in.)	<u>0.00</u>	2	14.6	1.8
Stack Area (ft ²)	<u>0.785</u>	3	29.6	3.6
		4	70.4	8.4
		5	85.4	10.2
		6	95.6	11.5



METHOD 1 DATA SHEET INLET SAMPLE LOCATION

Client: SCS Field Services

Date: 11/24/25

Location: Chiquita TF Canyon D

Performed By: SJ, AD, JI

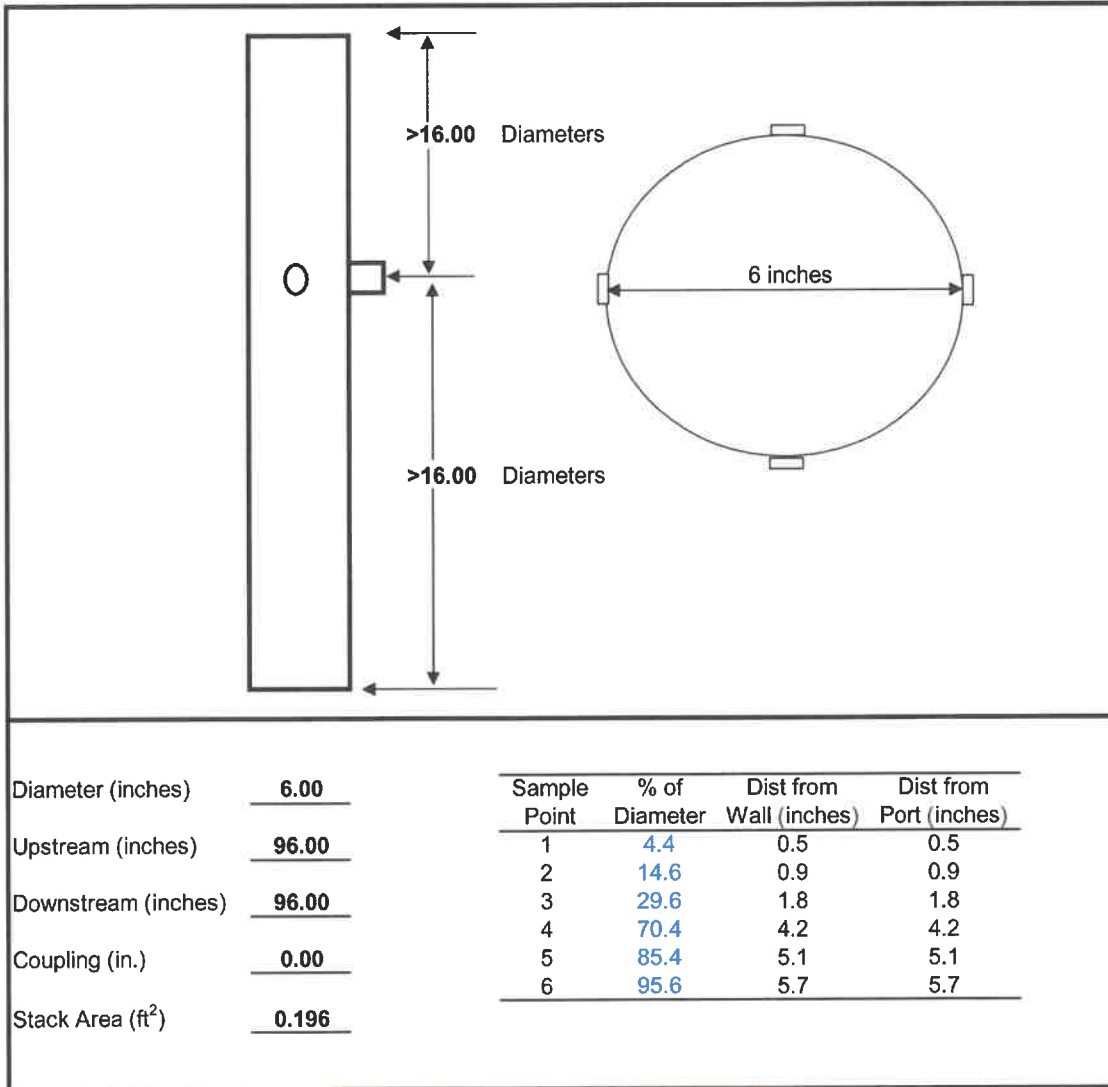

METHOD 1 DATA SHEET INLET SAMPLE LOCATION



Client: SCS Field Services

Date: 11/24/25

Location: Chiquita Tank Farm 13

Performed By: SJ, AD, JI

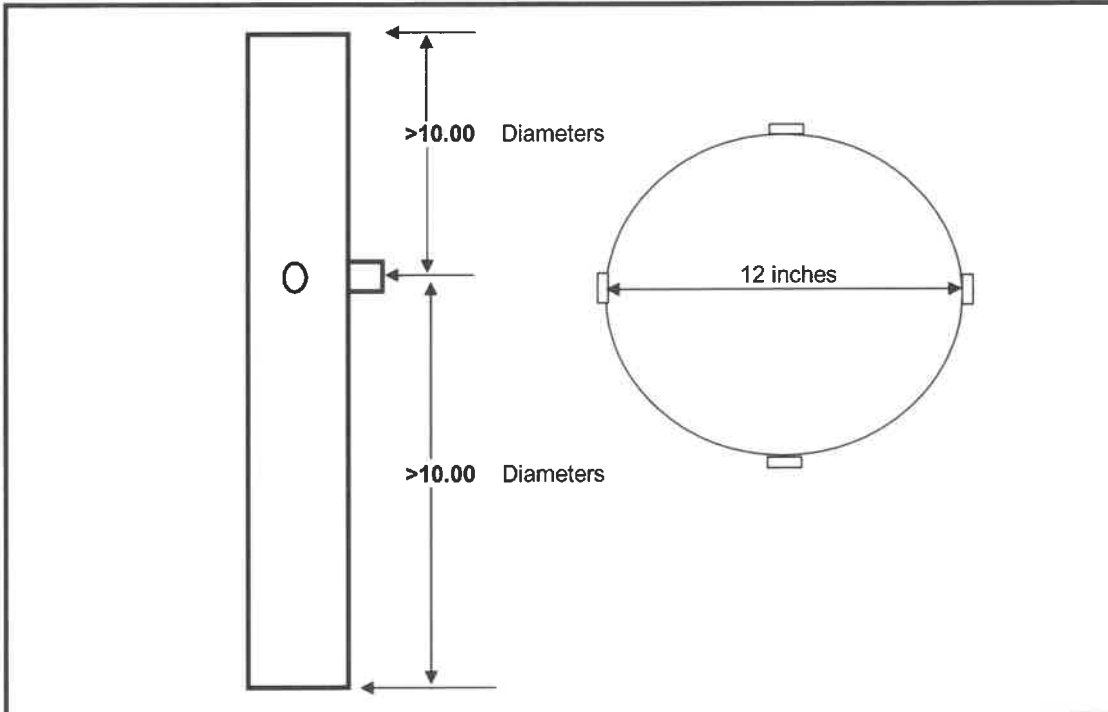

Diameter (inches)	12.00			
Upstream (inches)	120.00	Sample Point	% of Diameter	Dist from Wall (inches)
Downstream (inches)	120.00	1	4.4	0.5
Coupling (in.)	0.00	2	14.6	1.8
Stack Area (ft ²)	0.785	3	29.6	3.6
		4	70.4	8.4
		5	85.4	10.2
		6	95.6	11.5



METHOD 1 DATA SHEET INLET SAMPLE LOCATION

Client: SCS Field Services

Date: 11/24/25

Location: Flare Station Pre-H2S

Performed By: SJ, AD, JI

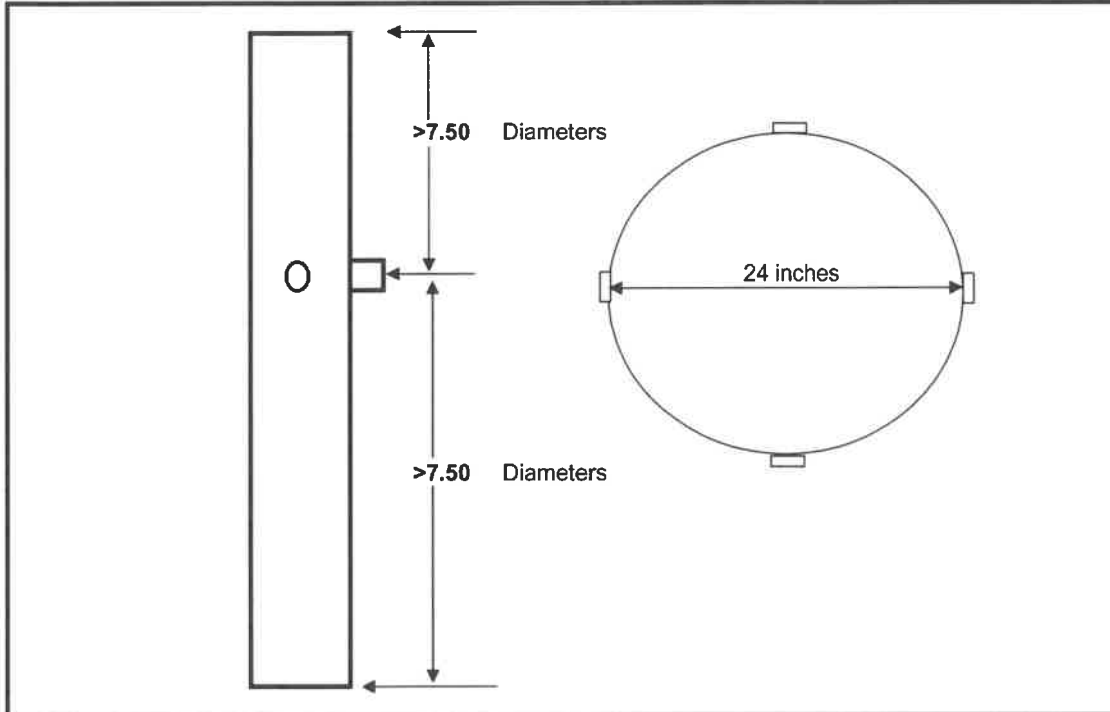

Diameter (inches)	<u>24.00</u>	Sample Point	% of Diameter	Dist from Wall (inches)	Dist from Port (inches)
Upstream (inches)	<u>180.00</u>	1	3.2	0.8	0.8
Downstream (inches)	<u>180.00</u>	2	10.5	2.5	2.5
Coupling (in.)	<u>0.00</u>	3	19.4	4.7	4.7
Stack Area (ft ²)	<u>3.142</u>	4	32.3	7.8	7.8
		5	67.7	16.2	16.2
		6	80.6	19.3	19.3
		7	89.5	21.5	21.5
		8	96.8	23.2	23.2



METHOD 1 DATA SHEET INLET SAMPLE LOCATION

Client: SCS Field Services

Date: 11/24/25

Location: Flare Station Post-H2S

Performed By: SJ, AD, JI

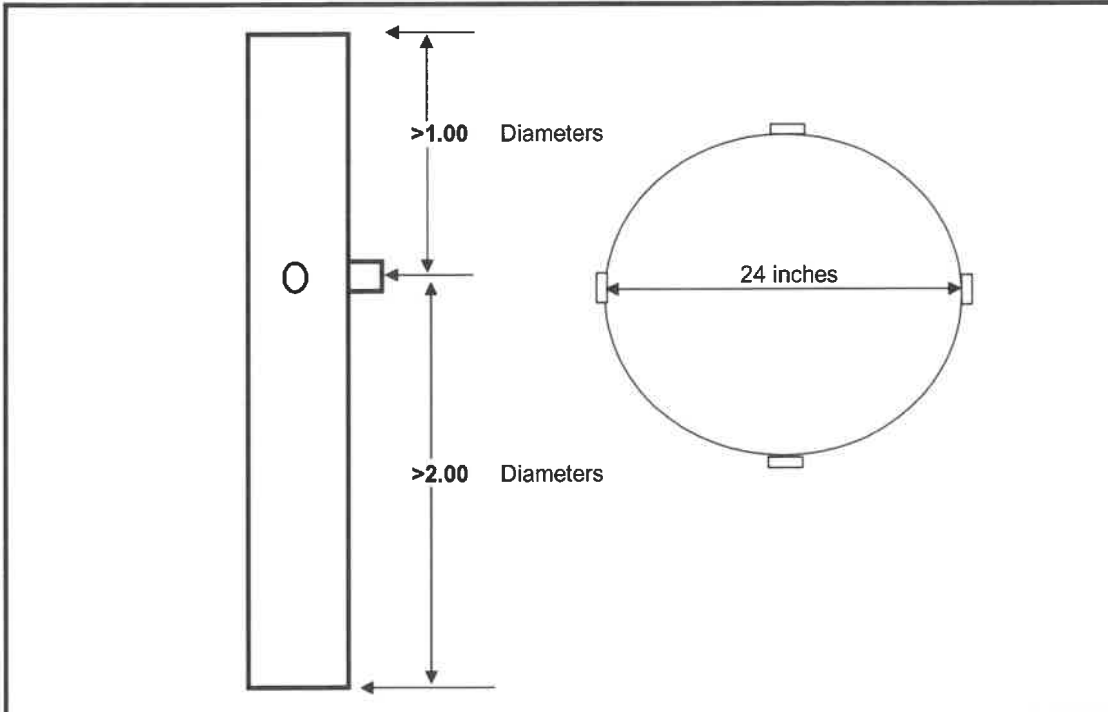

Diameter (inches)	<u>24.00</u>	Sample Point	% of Diameter	Dist from Wall (inches)	Dist from Port (inches)
Upstream (inches)	<u>48.00</u>	1	3.2	0.8	0.8
Downstream (inches)	<u>24.00</u>	2	10.5	2.5	2.5
Coupling (in.)	<u>0.00</u>	3	19.4	4.7	4.7
Stack Area (ft ²)	<u>3.142</u>	4	32.3	7.8	7.8
		5	67.7	16.2	16.2
		6	80.6	19.3	19.3
		7	89.5	21.5	21.5
		8	96.8	23.2	23.2



Appendix A.2

Velocity, Moisture and Flow Rate Data

MONTROSE AQS
Duct Moisture by Wet bulb/Dry bulb Measurements

Facility: Chiquita Canyon Landfill
 CEM I.D. : T-4

TEST DATE: November 24, 2025

BY: PSJ

$$B_{ws} = \frac{e''}{P_a}$$

$$e_a = e'' - \frac{(P_a - e'') [T_{dry} - T_{wet}]}{2800 - 1.3 \times T_{wet}}$$

	P _{bar}	Static Pressure (in. of H ₂ O)	P _a	T _{dry}	T _{wet}	e _a	B _{ws}	e''
Parnel	28.94	-12.60	28.0155	129	90	1.0271	3.67	1.413783
Zeeco	28.94	-12.00	28.0596	154	103	1.594286	5.68	2.091042
Hero	28.94	-6.40	28.4714	131	93	1.166092	4.10	1.54797
Tank Farm 7B	28.94	-0.010	28.9413	92	63	0.303304	1.05	0.605624
Canyon D	28.94	-0.050	28.9383	92	61	0.239758	0.83	0.56307
Tank Farm 13	28.94	-0.035	28.9394	94	62	0.250554	0.87	0.584219
Flare Station Pre	28.94	-0.070	28.9369	110	81	0.776493	2.68	1.076324
Flare Station Post	28.94	3.230	29.1795	108	81	0.79474	2.72	1.076324

**DATA AND WORKSHEET
RUN NUMBER 1**

TEST CONSTANTS				
Station: Chiquita Canyon Landfill				
Unit: Parnel				
Performed By: SJ, AD, JI				
Cp: 0.84				
T _{ref} : 60 °F				
Stack Area: 0.785 ft ²				
TEST VARIABLES				
Start Date: SJ, AD, JI				
Start/End Time: 7:30 8:00				
Test Condition: Normal				
Barom. Pressure: 28.94				
P _{stack} : -12.60 iwg				
P _{stack} : 28.02 "Hg				
MW Wet: 30.34 lb/lb-mole				
MW Dry: 30.81 lb/lb-mole				
Moisture				
Moisture Content: 3.67 % From WbDb				
Fuel Gas Composition Data				
O ₂ : 7.25 % From canister analysis				
CO ₂ : 40.44 % From canister analysis				
N ₂ : 30.39 % From canister analysis				
CH ₄ : 13.65 % From canister analysis				
METHOD 2.1 DATA				
Point	dP (in. H ₂ O)	sqrt(dP)	Temp °F	Vel. (fps)
1	0.330	0.5745	129	34.29
2	0.360	0.6000	129	35.81
3	0.390	0.6245	129	37.27
4	0.340	0.5831	129	34.80
5	0.330	0.5745	129	34.29
6	0.310	0.5568	129	33.23
1	0.320	0.5657	129	33.76
2	0.340	0.5831	129	34.80
3	0.330	0.5745	129	34.29
4	0.360	0.6000	129	35.81
5	0.380	0.6164	129	36.79
6	0.370	0.6083	129	36.30
Average	0.3463	0.5884	129	35.12
Flow Rate: 1,655 wacfm				
Flow Rate: 1,368 scfm				
Flow Rate: 1,318 dscfm				

FLUE GAS VELOCITY DATASHEET

CLIENT: W/c CHIQUITA PERFORMED BY: SS/AO/ST
 LOCATION: PARNEL FLARE INLET BAR. PRESSURE: 28.94
 UNIT: PARNEL STATIC PRESSURE: -12.60
 TEST DATE: 11/24/25 TC READOUT ID: PIC43
 TEST NUMBER: 1 TC ID: 180
 LEAK CHECK PRE- POST- PITOT TUBE ID: 180
 ΔP INDICATOR TYPE: ELECTRONIC PITOT TUBE COEFFICIENT: 0.84
 ΔP INDICATOR ID: ADM 850 #9 ZERO: LEVEL:

cycl Time	Port	Point	Vel. Head in. H ₂ O	Temp., °F	Time	Port	Point	Vel. Head in. H ₂ O	Temp., °F
3'	T	1	0.33	129	5'	S	1	0.32	129
7		2	0.36	129	1		2	0.34	129
1		3	0.39	129	0		3	0.33	129
2		4	0.34	129	3		4	0.36	129
1		5	0.33	129	3		5	0.38	129
4		6	0.31	129	1		6	0.37	129

Comments: _____

**DATA AND WORKSHEET
RUN NUMBER 1**

TEST CONSTANTS				
Station: Chiquita Canyon Landfill				
Unit: ZEECO				
Performed By: SJ, AD, JI				
Cp: 0.84				
T _{ref} : 60 °F				
Stack Area: 0.785 ft ²				
TEST VARIABLES				
Start Date: SJ, AD, JI				
Start/End Time: 7:30 8:00				
Test Condition: Normal				
Barom. Pressure: 28.94				
Pstack: -12.0 iwg				
Pstack: 28.06 "Hg				
MW Wet: 29.31 lb/lb-mole				
MW Dry: 29.99 lb/lb-mole				
Moisture				
Moisture Content: 5.68 % From WbDb				
Fuel Gas Composition Data				
O ₂ : 8.83 % From canister analysis				
CO ₂ : 30.39 % From canister analysis				
N ₂ : 39.85 % From canister analysis				
CH ₄ : 16.47 % From canister analysis				
METHOD 2.1 DATA				
Point	dP (in. H ₂ O)	sqrt(dP)	Temp °F	Vel. (fps)
1	1.110	1.0536	154	65.27
2	1.170	1.0817	154	67.01
3	1.150	1.0724	154	66.43
4	1.190	1.0909	154	67.58
5	1.180	1.0863	154	67.29
6	1.200	1.0954	154	67.86
1	1.150	1.0724	154	66.43
2	1.190	1.0909	154	67.58
3	1.200	1.0954	154	67.86
4	1.230	1.1091	154	68.70
5	1.200	1.0954	154	67.86
6	1.210	1.1000	154	68.14
Average	1.1815	1.0870	154	67.33
Flow Rate: 3,173 wacfm				
Flow Rate: 2,520 scfm				
Flow Rate: 2,377 dscfm				

FLUE GAS VELOCITY DATASHEET

CLIENT: W/C CHIQUITA PERFORMED BY: JS / AD / JJ
 LOCATION: INLET BAR. PRESSURE: 28.94
 UNIT: ZEEO STATIC PRESSURE: -12.0
 TEST DATE: 11/24/25 TC READOUT ID: PTC43
 TEST NUMBER: 1 TC ID: 180
 LEAK CHECK PRE- POST- PITOT TUBE ID: 180
 ΔP INDICATOR TYPE: ELECTRONIC PITOT TUBE COEFFICIENT: 0.84
 ΔP INDICATOR ID: ADM 850 #9 ZERO: LEVEL:

CYCL Time	T Port	Point	Vel. Head in. H ₂ O	Temp., °F	CYCL Time	S Port	Point	Vel. Head in. H ₂ O	Temp., °F
3°		1	1.11	154	5°		1	1.15	154
4		2	1.17	154	3		2	1.19	154
9		3	1.15	154	1		3	1.20	154
1		4	1.19	154	0		4	1.23	154
4		5	1.18	154	7		5	1.20	154
2		6	1.20	154	1		6	1.21	154

Comments: _____

**DATA AND WORKSHEET
RUN NUMBER 1**

TEST CONSTANTS				
Station: Chiquita Canyon Landfill				
Unit: Hero				
Performed By: SJ, AD, JI				
Cp: 0.84				
T _{ref} : 60 °F				
Stack Area: 0.349 ft ²				
TEST VARIABLES				
Start Date: SJ, AD, JI				
Start/End Time: 8:10 8:40				
Test Condition: Normal				
Barom. Pressure: 28.94				
P _{stack} : -6.4 iwg				
P _{stack} : 28.47 "Hg				
MW Wet: 30.22 lb/lb-mole				
MW Dry: 30.74 lb/lb-mole				
Moisture				
Moisture Content: 4.10 % From WbDb				
Fuel Gas Composition Data				
O ₂ : 7.25 % From canister analysis				
CO ₂ : 40.67 % From canister analysis				
N ₂ : 30.45 % From canister analysis				
CH ₄ : 12.52 % From canister analysis				
METHOD 2.1 DATA				
Point	dP (in. H ₂ O)	sqrt(dP)	Temp °F	Vel. (fps)
1	0.320	0.5657	131	33.61
2	0.350	0.5916	131	35.15
3	0.310	0.5568	131	33.08
4	0.310	0.5568	131	33.08
5	0.360	0.6000	131	35.65
6	0.340	0.5831	131	34.65
1	0.280	0.5292	131	31.44
2	0.330	0.5745	131	34.13
3	0.370	0.6083	131	36.14
4	0.390	0.6245	131	37.11
5	0.400	0.6325	131	37.58
6	0.370	0.6083	131	36.14
Average	0.3433	0.5859	131	34.81
Flow Rate: 729 wacfm				
Flow Rate: 610 scfm				
Flow Rate: 585 dscfm				

FLUE GAS VELOCITY DATASHEET

CLIENT: <u>W/C CH. QUITA</u>	PERFORMED BY: <u>ST/AO/ST</u>
LOCATION: <u>INLET</u>	BAR. PRESSURE: <u>20.97</u>
UNIT: <u>HONO</u>	STATIC PRESSURE: <u>-6.7</u>
TEST DATE: <u>11/24/25</u>	TC READOUT ID: <u>PTC43</u>
TEST NUMBER: <u>1</u>	TC ID: <u>180</u>
LEAK CHECK PRE- <input checked="" type="checkbox"/> POST- <input checked="" type="checkbox"/>	PITOT TUBE ID: <u>180</u>
ΔP INDICATOR TYPE: <u>ELECTRONIC</u>	PITOT TUBE COEFFICIENT: <u>0.84</u>
ΔP INDICATOR ID: <u>ADM 850 #2</u>	ZERO: <input checked="" type="checkbox"/> LEVEL: <input checked="" type="checkbox"/>

Cycl Time	T Port	Point	Vel. Head in. H ₂ O	Temp., °F	Cycl Time	S Port	Point	Vel. Head in. H ₂ O	Temp., °F
6		1	0.32	131	2		1	0.28	131
3		2	0.35	131	2		2	0.33	131
1		3	0.31	131	5		3	0.37	131
4		4	0.31	131	1		4	0.37	131
7		5	0.36	131	4		5	0.40	131
0		6	0.34	131	3		6	0.37	131

Comments: _____

**DATA AND WORKSHEET
RUN NUMBER 1**

TEST CONSTANTS				
Station: Chiquita Canyon Landfill				
Unit: Tank Farm 7B				
Performed By: SJ, AD, JI				
Cp: 0.84				
T _{ref} : 60 °F				
Stack Area: 0.785 ft ²				
TEST VARIABLES				
Start Date: SJ, AD, JI				
Start/End Time: 8:45 9:15				
Test Condition: Normal				
Barom. Pressure: 28.94				
P _{stack} : -0.010 iwg				
P _{stack} : 28.94 "Hg				
MW Wet: 28.34 lb/lb-mole				
MW Dry: 28.45 lb/lb-mole				
Moisture				
Moisture Content: 1.05 % From WbDb				
Fuel Gas Composition Data				
O ₂ : 8.27 % From canister analysis				
CO ₂ : 26.34 % From canister analysis				
N ₂ : 36.15 % From canister analysis				
CH ₄ : 25.55 % From canister analysis				
METHOD 2.1 DATA				
Point	dP (in. H ₂ O)	sqrt(dP)	Temp °F	Vel. (fps)
1	0.045	0.2121	92	12.48
2	0.051	0.2258	92	13.28
3	0.049	0.2214	92	13.02
4	0.050	0.2236	92	13.15
5	0.047	0.2168	92	12.75
6	0.046	0.2145	92	12.62
1	0.042	0.2049	92	12.05
2	0.048	0.2191	92	12.89
3	0.051	0.2258	92	13.28
4	0.052	0.2280	92	13.41
5	0.050	0.2236	92	13.15
6	0.057	0.2387	92	14.04
Average	0.0489	0.2212	92	13.01
Flow Rate: 613 wacfm				
Flow Rate: 559 scfm				
Flow Rate: 553 dscfm				

FLUE GAS VELOCITY DATASHEET

CLIENT: W/C CHIQUITA PERFORMED BY: ST/AD/ST
 LOCATION: TANK FARM 73 BAR. PRESSURE: 29.94
 UNIT: IN/FT STATIC PRESSURE: -0.010
 TEST DATE: 11/24/25 TC READOUT ID: P1C43
 TEST NUMBER: 1 TC ID: 180
 LEAK CHECK PRE- POST- PITOT TUBE ID: 180
 ΔP INDICATOR TYPE: ELECTRONIC PITOT TUBE COEFFICIENT: 0.84
 ΔP INDICATOR ID: ADM 850 #19 ZERO: LEVEL:

Cycle Time	T Port	Point	Vel. Head in. H ₂ O	Temp., °F	Cycle Time	S Port	Point	Vel. Head in. H ₂ O	Temp., °F
20		1	0.045	92	7		1	0.042	92
5		2	0.051	92	7		2	0.048	92
3		3	0.049	92	3		3	0.059	92
1		4	0.050	92	1		4	0.052	92
7		5	0.047	92	6		5	0.050	92
0		6	0.046	92	2		6	0.057	92

Comments: _____

**DATA AND WORKSHEET
RUN NUMBER 1**

TEST CONSTANTS				
Station: Chiquita Canyon Landfill				
Unit: Canyon D				
Performed By: SJ, AD, JI				
Cp: 0.84				
T _{ref} : 60 °F				
Stack Area: 0.196 ft ²				
TEST VARIABLES				
Start Date: SJ, AD, JI				
Start/End Time: 9:20 9:50				
Test Condition: Normal				
Barom. Pressure: 28.94				
P _{stack} : -0.050 iwg				
P _{stack} : 28.94 "Hg				
MW Wet: 28.33 lb/lb-mole				
MW Dry: 28.41 lb/lb-mole				
Moisture				
Moisture Content: 0.83 % From WbDb				
Fuel Gas Composition Data				
O ₂ : 21.36 % From canister analysis				
CO ₂ : 0.58 % From canister analysis				
N ₂ : 76.10 % From canister analysis				
CH ₄ : <0.10 % From canister analysis				
METHOD 2.1 DATA				
Point	dP (in. H ₂ O)	sqrt(dP)	Temp °F	Vel. (fps)
1	0.078	0.2793	92	16.43
2	0.081	0.2846	92	16.74
3	0.080	0.2828	92	16.64
4	0.082	0.2864	92	16.85
5	0.084	0.2898	92	17.05
6	0.083	0.2881	92	16.95
1	0.077	0.2775	92	16.32
2	0.084	0.2898	92	17.05
3	0.082	0.2864	92	16.85
4	0.085	0.2915	92	17.15
5	0.083	0.2881	92	16.95
6	0.075	0.2739	91	16.10
Average	0.0811	0.2848	92	16.76
Flow Rate: 197 wacfm				
Flow Rate: 180 scfm				
Flow Rate: 178 dscfm				

FLUE GAS VELOCITY DATASHEET

CLIENT: W/C CHIRQUITA PERFORMED BY: ST/AD/JF
 LOCATION: INIST BAR. PRESSURE: 2894
 UNIT: CANYON D STATIC PRESSURE: -0.050
 TEST DATE: 11/24/25 TC READOUT ID: PTC43
 TEST NUMBER: 1 TC ID: 180
 LEAK CHECK PRE- POST- PITOT TUBE ID: 180
 ΔP INDICATOR TYPE: ELECTRONIC PITOT TUBE COEFFICIENT: 0.84
 ΔP INDICATOR ID: ADM 850 #2 ZERO: LEVEL:

CYCL Time	T Port	Point	Vel. Head in. H ₂ O	Temp., °F	CYCL Time	S Port	Point	Vel. Head in. H ₂ O	Temp., °F
3'		1	0.078	92	2'		1	0.077	92
6		2	0.081	92	4		2	0.084	92
1		3	0.080	92	7		3	0.082	92
7		4	0.082	92	1		4	0.085	92
5		5	0.084	92	6		5	0.083	92
3		6	0.083	92	4		6	0.075	92

Comments: _____

**DATA AND WORKSHEET
RUN NUMBER 1**

TEST CONSTANTS				
Station: Chiquita Canyon Landfill				
Unit: Tank Farm 13				
Performed By: SJ, AD, JI				
Cp: 0.84				
T _{ref} : 60 °F				
Stack Area: 0.785 ft ²				
TEST VARIABLES				
Start Date: SJ, AD, JI				
Start/End Time: 9:20 9:50				
Test Condition: Normal				
Barom. Pressure: 28.94				
P _{stack} : -0.035 iwg				
P _{stack} : 28.94 "Hg				
MW Wet: 28.33 lb/lb-mole				
MW Dry: 28.42 lb/lb-mole				
Moisture				
Moisture Content: 0.87 % From WbDb				
Fuel Gas Composition Data				
O ₂ : 21.30 % From canister analysis				
CO ₂ : 0.82 % From canister analysis				
N ₂ : 75.82 % From canister analysis				
CH ₄ : <0.10 % From canister analysis				
METHOD 2.1 DATA				
Point	dP (in. H ₂ O)	sqrt(dP)	Temp °F	Vel. (fps)
1	0.016	0.1265	94	7.45
2	0.014	0.1183	94	6.97
3	0.018	0.1342	94	7.91
4	0.017	0.1304	94	7.68
5	0.015	0.1225	94	7.22
6	0.013	0.1140	94	6.72
1	0.012	0.1095	94	6.46
2	0.010	0.1000	94	5.89
3	0.011	0.1049	94	6.18
4	0.013	0.1140	94	6.72
5	0.016	0.1265	94	7.45
6	0.012	0.1095	94	6.46
Average	0.0138	0.1175	94	6.93
Flow Rate: 326 wacfm				
Flow Rate: 296 scfm				
Flow Rate: 294 dscfm				

FLUE GAS VELOCITY DATASHEET

CLIENT: W/C / CH. QUITA PERFORMED BY: SS / AG / JT
 LOCATION: TANK FARM 13 BAR. PRESSURE: 28.94
 UNIT: INLET STATIC PRESSURE: -0.035
 TEST DATE: 11/24/25 TC READOUT ID: PR243
 TEST NUMBER: 1 TC ID: 180
 LEAK CHECK PRE- POST- PITOT TUBE ID: 180
 ΔP INDICATOR TYPE: ELECTRONIC PITOT TUBE COEFFICIENT: 0.84
 ΔP INDICATOR ID: ADM 850 #9 ZERO: LEVEL:

Cycle Time	S Port	Point	Vel. Head in. H ₂ O	Temp., °F	Cycle Time	S Port	Point	Vel. Head in. H ₂ O	Temp., °F
6		1	0.014	94	3		1	0.012	94
1		2	0.014	94	5		2	0.010	94
7		3	0.013	94	9		3	0.011	94
9		4	0.017	94	2		4	0.013	94
2		5	0.015	94	1		5	0.014	94
4		6	0.013	94	0		6	0.012	94

Comments: _____

**DATA AND WORKSHEET
RUN NUMBER 1**

TEST CONSTANTS				
Station: Chiquita Canyon Landfill				
Unit: Flare Station Pre-H2S				
Performed By: SJ, AD, JI				
Cp: 0.84				
T _{ref} : 60 °F				
Stack Area: 3.142 ft ²				
TEST VARIABLES				
Start Date: SJ, AD, JI				
Start/End Time: 10:00 10:30				
Test Condition: Normal				
Barom. Pressure: 28.94				
P _{stack} : -0.07 iwg				
P _{stack} : 28.94 "Hg				
MW Wet: 28.94 lb/lb-mole				
MW Dry: 29.24 lb/lb-mole				
Moisture				
Moisture Content: 2.68 % From WbDb				
Fuel Gas Composition Data				
O ₂ : 4.83 % From canister analysis				
CO ₂ : 38.03 % From canister analysis				
N ₂ : 22.43 % From canister analysis				
CH ₄ : 29.28 % From canister analysis				
METHOD 2.1 DATA				
Point	dP (in. H ₂ O)	sqrt(dP)	Temp °F	Vel. (fps)
1	0.021	0.1449	110	8.57
2	0.024	0.1549	110	9.16
3	0.026	0.1612	110	9.54
4	0.022	0.1483	110	8.77
5	0.021	0.1449	110	8.57
6	0.025	0.1581	110	9.35
7	0.027	0.1643	110	9.72
8	0.024	0.1549	110	9.16
1	0.028	0.1673	110	9.90
2	0.027	0.1643	110	9.72
3	0.033	0.1817	110	10.74
4	0.037	0.1924	110	11.38
5	0.036	0.1897	110	11.22
6	0.035	0.1871	110	11.07
7	0.031	0.1761	110	10.41
8	0.033	0.1817	110	10.74
Average	0.0279	0.1670	110	9.88
Flow Rate: 1,862 wacfm				
Flow Rate: 1,643 scfm				
Flow Rate: 1,599 dscfm				

FLUE GAS VELOCITY DATASHEET

CLIENT: <u>WLC CHIRQUITA</u>	PERFORMED BY: <u>ST / AD / ST</u>
LOCATION: <u>FIARE STATION PRE H2S</u>	BAR. PRESSURE: <u>28.94</u>
UNIT: <u>PRE H2S</u>	STATIC PRESSURE: <u>-0.07</u>
TEST DATE: <u>11/24/23</u>	TC READOUT ID: <u>PTC43</u>
TEST NUMBER: <u>1</u>	TC ID: <u>180</u>
LEAK CHECK PRE- <input checked="" type="checkbox"/> POST- <input checked="" type="checkbox"/>	PITOT TUBE ID: <u>180</u>
ΔP INDICATOR TYPE: <u>ELECTRONIC</u>	PITOT TUBE COEFFICIENT: <u>0.84</u>
ΔP INDICATOR ID: <u>ADM 850 #2</u>	ZERO: <input checked="" type="checkbox"/> LEVEL: <input checked="" type="checkbox"/>

<u>Cycle</u> Time	<u>A</u> Port	Point	Vel. Head in. H ₂ O	Temp., °F	<u>Cycle</u> Time	<u>B</u> Port	Point	Vel. Head in. H ₂ O	Temp., °F
7		1	0.021	110	3		1	0.028	110
1		2	0.024	110	6		2	0.027	110
5		3	0.026	110	0		3	0.033	110
3		4	0.022	110	1		4	0.037	110
6		5	0.021	110	7		5	0.034	110
2		6	0.025	110	1		6	0.035	110
2		7	0.027	110	5		7	0.031	110
4		8	0.024	110	3		8	0.033	110

Comments: _____

**DATA AND WORKSHEET
RUN NUMBER 1**

TEST CONSTANTS				
Station: Chiquita Canyon Landfill				
Unit: Flare Station Post-H2S				
Performed By: SJ, AD, JI				
Cp: 0.84				
T _{ref} : 60 °F				
Stack Area: 3.142 ft ²				
TEST VARIABLES				
Start Date: SJ, AD, JI				
Start/End Time: 10:00 10:30				
Test Condition: Normal				
Barom. Pressure: 28.94				
Pstack: 3.23 iwg				
Pstack: 29.18 "Hg				
MW Wet: 28.88 lb/lb-mole				
MW Dry: 29.19 lb/lb-mole				
Moisture				
Moisture Content: 2.72 % From WbDb				
Fuel Gas Composition Data				
O ₂ : 5.35 % From canister analysis				
CO ₂ : 36.87 % From canister analysis				
N ₂ : 24.12 % From canister analysis				
CH ₄ : 28.13 % From canister analysis				
METHOD 2.1 DATA				
Point	dP (in. H ₂ O)	sqrt(dP)	Temp °F	Vel. (fps)
1	0.030	0.1732	108	10.19
2	0.027	0.1643	108	9.67
3	0.026	0.1612	108	9.49
4	0.022	0.1483	108	8.73
5	0.025	0.1581	108	9.31
6	0.027	0.1643	108	9.67
7	0.030	0.1732	108	10.19
8	0.029	0.1703	108	10.02
1	0.026	0.1612	108	9.49
2	0.032	0.1789	108	10.53
3	0.031	0.1761	108	10.36
4	0.030	0.1732	108	10.19
5	0.031	0.1761	108	10.36
6	0.029	0.1703	108	10.02
7	0.025	0.1581	108	9.31
8	0.024	0.1549	108	9.12
Average	0.0277	0.1664	108	9.79
Flow Rate: 1,846 wacfm				
Flow Rate: 1,648 scfm				
Flow Rate: 1,603 dscfm				

FLUE GAS VELOCITY DATASHEET

CLIENT: W/C CIRCUITA PERFORMED BY: ST/AD/JT
 LOCATION: FARE STATION BAR. PRESSURE: 29.97
 UNIT: POST #25 STATIC PRESSURE: 3.23
 TEST DATE: 11/24/25 TC READOUT ID: PTL43
 TEST NUMBER: 1 TC ID: 180
 LEAK CHECK PRE- POST- PITOT TUBE ID: 180
 ΔP INDICATOR TYPE: ELECTRONIC PITOT TUBE COEFFICIENT: 0.84
 ΔP INDICATOR ID: ADM 850 #2 ZERO: LEVEL:

CYCL Time	A Port	Point	Vel. Head in. H ₂ O	Temp., °F	CYCL Time	B Port	Point	Vel. Head in. H ₂ O	Temp., °F
6°		1	0.030	100	2°		1	0.026	108
1		2	0.027	108	7		2	0.032	108
2		3	0.026	108	1		3	0.031	108
4		4	0.022	108	6		4	0.030	108
7		5	0.025	108	5		5	0.031	108
3		6	0.027	108	9		6	0.027	108
0		7	0.030	108	4		7	0.025	108
2		8	0.029	108	2		8	0.024	108

Comments: _____

Appendix A.3

Organics and Sulfur Field and Laboratory Data

LEACHATE TANK HEADSPACE SAMPLING DATA

Client/Facility: W/C CHIRQUITA Date: 1/24/25
 Unit/Location: PARSELL INLET Performed By: ST/AD/OI
 Barometric Pressure 28.94 Ambient Temperature 73°

SUMMA CANISTER DATA

Test No.	1		
Canister ID	236021		
		Time	Vacuum
Pre-Test Leak Check	Start	0710	30
Pre-Test Leak Check	Stop	0720	30
Sample Collection	Start	0730	30
	10	0740	22
	20	0750	14
	end → 30	0800	5
Sample Collection	Stop		
Post -Test Leak Check	Start	0820	5
Post-Test Leak Check	Stop	0830	5

FLOWRATE DATA

Diameter: 12"
 Upstream: 120"
 Downstream: 40"
 Flow Rate: 1376 scfm
 Wet bulb: 90
 Dry bulb: 129

TEDLAR BAG DATA

Start: N/A
 Stop: N/A
 Bag ID: _____

LEACHATE TANK HEADSPACE SAMPLING DATA

Client/Facility: W/C CHIRQUITA Date: 1/24/25
 Unit/Location: REECO INLET Performed By: ST/AD/JE
 Barometric Pressure 28.74 Ambient Temperature 73°

SUMMA CANISTER DATA

Test No.		1	
Canister ID		246043	
		Time	Vacuum
Pre-Test Leak Check	Start	0710	30
Pre-Test Leak Check	Stop	0720	30
Sample Collection	Start	0730	30
	10	0740	21
	20	0750	15
	end → 30	0800	5
Sample Collection	Stop		
Post -Test Leak Check	Start	0820	5
Post-Test Leak Check	Stop	0830	5

FLOWRATE DATA

Diameter: 12"
 Upstream: 180"
 Downstream: 180"
 Flow Rate: ~~137~~ 2495 SCFM
 Wet bulb: 103
 Dry bulb: 154

TEDLAR BAG DATA

Start: N/A
 Stop: N/A
 Bag ID: _____

LEACHATE TANK HEADSPACE SAMPLING DATA

Client/Facility: W/C CHICQUITA Date: 11/24/25
 Unit/Location: HERO INLET Performed By: SA/AD/JF
 Barometric Pressure 28.94 Ambient Temperature 73°

SUMMA CANISTER DATA

Test No.	1		
Canister ID	236017		
		Time	Vacuum
Pre-Test Leak Check	Start	0710	30
Pre-Test Leak Check	Stop	0720	30
Sample Collection	Start	0810	30
	10	0820	21
	20	0830	15
	end → 30	0840	5
Sample Collection	Stop		
Post-Test Leak Check	Start	0850	5
Post-Test Leak Check	Stop	0900	5

FLOWRATE DATA

Diameter: 8"
 Upstream: 64"
 Downstream: 16"
 Flow Rate: 613 SCFM
 Wet bulb: 93
 Dry bulb: 131

TEDLAR BAG DATA

Start: _____
 Stop: N/A
 Bag ID: _____

LEACHATE TANK HEADSPACE SAMPLING DATA

Client/Facility: W/C CHIRQUITA Date: 11/24/25
 Unit/Location: TANK ROOM 7B Performed By: ST/AD/BI
 Barometric Pressure 28.94 Ambient Temperature 73°

SUMMA CANISTER DATA

Test No.			
Canister ID		<u>246051</u>	
		Time	Vacuum
Pre-Test Leak Check	Start	<u>0710</u>	<u>30</u>
Pre-Test Leak Check	Stop	<u>0720</u>	<u>30</u>
Sample Collection	Start	<u>0845</u>	<u>30</u>
	<u>10</u>	<u>0855</u>	<u>20</u>
	<u>20</u>	<u>0905</u>	<u>16</u>
<u>End</u>	<u>30</u>	<u>0915</u>	<u>5</u>
Sample Collection	Stop		
Post-Test Leak Check	Start	<u>0930</u>	<u>5</u>
Post-Test Leak Check	Stop	<u>0940</u>	<u>5</u>

FLOWRATE DATA

Diameter: 12"
 Upstream: 180"
 Downstream: 180"
 Flow Rate: 573 SCFH
 Wet bulb: 63
 Dry bulb: 72

TEDLAR BAG DATA

Start: _____
 Stop: N/A
 Bag ID: _____

LEACHATE TANK HEADSPACE SAMPLING DATA

Client/Facility: W/C CHIRQUITA Date: 11/24/25

Unit/Location: TANK FARM CANON D Performed By: ST/AD/JI

Barometric Pressure 28.94 Ambient Temperature 73°

SUMMA CANISTER DATA

Test No.	1		
Canister ID	246049		
		Time	Vacuum
Pre-Test Leak Check	Start	0710	30
Pre-Test Leak Check	Stop	0720	30
Sample Collection	Start	0920	30
	10	0930	23
	20	0940	14
end	30	0950	5
Sample Collection	Stop	(5)	
Post-Test Leak Check	Start	1000 0930	5
Post-Test Leak Check	Stop	1010 0940	5

FLOWRATE DATA

Diameter: 6"

Upstream: 96"

Downstream: 76"

Flow Rate: 187 scfm

Wet bulb: 61

Dry bulb: 92

TEDLAR BAG DATA

Start: _____

Stop: N/A

Bag ID: _____

LEACHATE TANK HEADSPACE SAMPLING DATA

Client/Facility: W/C CHIRQUITA Date: 11/24/25

Unit/Location: TANK FARM 13 Performed By: SS/AD/SE

Barometric Pressure 29.94 Ambient Temperature 73°

SUMMA CANISTER DATA

Test No.			
Canister ID		236014	
		Time	Vacuum
Pre-Test Leak Check	Start	0710	30
Pre-Test Leak Check	Stop	0720	30
Sample Collection	Start	0920	30
	10	0930	22
	20	0940	14
	30	0950	5
Sample Collection	Stop		
Post-Test Leak Check	Start	1000	5
Post-Test Leak Check	Stop	1010	5

FLOWRATE DATA

Diameter: 12"

Upstream: 120"

Downstream: 120"

Flow Rate: 285 scfm

Wet bulb: 62

Dry bulb: 94

TEDLAR BAG DATA

Start: _____

Stop: N/A

Bag ID: _____

LEACHATE TANK HEADSPACE SAMPLING DATA

Client/Facility: W/C CHIRQUITA Date: 11/24/25

Unit/Location: FLARE STATION PRE #25 Performed By: ST/AD/JT

Barometric Pressure 28.94 Ambient Temperature 73°

SUMMA CANISTER DATA

Test No.		1	
Canister ID		23C018	
		Time	Vacuum
Pre-Test Leak Check	Start	0710	30
Pre-Test Leak Check	Stop	0720	30
Sample Collection	Start	1000	30
	10	1000	23
	20	1020	15
	end= 30	1030	5
Sample Collection	Stop		
Post-Test Leak Check	Start	1040	5
Post-Test Leak Check	Stop	1050	5

FLOWRATE DATA

Diameter: 24"

Upstream: 180"

Downstream: 180"

Flow Rate: N/A

Wet bulb: 81

Dry bulb: 110

TEDLAR BAG DATA

Start: N/A

Stop: N/A

Bag ID: N/A

LEACHATE TANK HEADSPACE SAMPLING DATA

Client/Facility: W/C CHIRQUITA Date: 11/24/25
 Unit/Location: FLAME STATION POSTHUS Performed By: ST/AD/ST
 Barometric Pressure 2894 Ambient Temperature 73°

SUMMA CANISTER DATA

Test No.		1	
Canister ID		236028	
		Time	Vacuum
Pre-Test Leak Check	Start	0710	30
Pre-Test Leak Check	Stop	0720	30
Sample Collection	Start	1000	30
	10	1010	22
	20	1020	14
	end - 30	1030	5
Sample Collection	Stop		
Post -Test Leak Check	Start	1040	5
Post-Test Leak Check	Stop	1050	5

FLOWRATE DATA

Diameter: 24"
 Upstream: 48'
 Downstream: 24"
 Flow Rate: N/A
 Wet bulb: 81
 Dry bulb: 108

TEDLAR BAG DATA

Start: N/A
 Stop: N/A
 Bag ID: N/A



AtmAA Inc.

5107 Douglas Fir Rd., Calabasas, CA 91302 • (818) 223-3277

specialized air assessment laboratory
atmaa.com

LABORATORY ANALYSIS REPORT

Permanent Gases Analysis in Silco Canister Samples by Method ASTM D1946-90

Report Date: December 2, 2025
Client: Montrose AQS
Project Location: Chiquita Landfill
Project No.: PROJ-061273
Date Received: November 24, 2025
Date Analyzed: December 1, 2025

ANALYSIS DESCRIPTION

Permanent gases were measured by thermal conductivity detection/gas chromatography (TCD/GC), ASTM D1946-90.

AtmAA Lab No.:	23285-36	23285-37	23285-38
Sample I.D.:	Parnell Inlet	Zeeco Inlet	Hero Inlet

Components	(Concentration in %v)		
Nitrogen	30.39	39.85	30.45
Oxygen	7.25	8.83	7.25
Methane	13.65	16.47	12.52
Carbon dioxide	40.44	30.39	40.67
Hydrogen	4.02	1.40	4.67

The reported oxygen concentration includes any argon present in the sample. Calibration is based on a standard atmosphere containing 20.95% oxygen and 0.93% argon. The accuracy of permanent gas analysis by TCD/GC is +/- 2%, actual results are reported. Actual analysis results are reported on a "wet" basis.

Brian W. Fung
Laboratory Director

QUALITY ASSURANCE SUMMARY
(Repeat Analyses)

Project Location: Chiquita Landfill
Date Received: November 24, 2025
Date Analyzed: December 1, 2025

Components	Sample ID	Repeat Analysis		Mean Conc.	% RPD	
		Run #1	Run #2			
		<i>(Concentration in %v)</i>				
Nitrogen	Parnell Inlet	30.33	30.44	30.39	0.36	
Oxygen	Parnell Inlet	7.23	7.27	7.25	0.55	
Methane	Parnell Inlet	13.65	13.65	13.65	0.00	
Carbon dioxide	Parnell Inlet	40.43	40.44	40.44	0.02	
Hydrogen	Parnell Inlet	3.98	4.06	4.02	2.0	

Three Silco canister samples, laboratory numbers 23285-(36-38), were analyzed for permanent gases. Agreement between repeat analyses is a measure of precision and is shown above in the column "% RPD". The average % RPD for 5 repeat measurements from three Silco canister samples is 0.58%.





AtmAA Inc.

5107 Douglas Fir Rd., Calabasas, CA 91302 • (818) 223-3277

specialized air assessment laboratory
atmaa.com

LABORATORY ANALYSIS REPORT

Permanent Gases Analysis in Silco Canister Samples by Method ASTM D1946-90

Report Date: December 2, 2025
Client: Montrose AQS
Project Location: Chiquita Landfill
Project No.: PROJ-061273
Date Received: November 24, 2025
Date Analyzed: December 1, 2025

ANALYSIS DESCRIPTION

Permanent gases were measured by thermal conductivity detection/gas chromatography (TCD/GC), ASTM D1946-90.

AtmAA Lab No.:	23285-39	23285-40	23285-41
Sample I.D.:	TF 7B	Canyon D	TF 13

Components	(Concentration in %v)		
Nitrogen	36.15	76.10	75.82
Oxygen	8.27	21.36	21.30
Methane-	25.55	<0.10	<0.10
Carbon dioxide	26.34	0.58	0.82
Hydrogen	0.42	<0.10	<0.10

The reported oxygen concentration includes any argon present in the sample. Calibration is based on a standard atmosphere containing 20.95% oxygen and 0.93% argon. The accuracy of permanent gas analysis by TCD/GC is +/- 2%, actual results are reported. Actual analysis results are reported on a "wet" basis.



Brian W. Fung
Laboratory Director

QUALITY ASSURANCE SUMMARY
(Repeat Analyses)

Project Location: Chiquita Landfill
Date Received: November 24, 2025
Date Analyzed: December 1, 2025

Components	Sample ID	Repeat Analysis		Mean Conc.	% RPD
		Run #1	Run #2		
		(Concentration in %v)			
Nitrogen	TF 7B	36.23	36.06	36.15	0.47
Oxygen	TF 7B	8.28	8.26	8.27	0.24
Methane	TF 7B	25.64	25.45	25.55	0.74
Carbon dioxide	TF 7B	26.40	26.27	26.34	0.49

Three Silco canister samples, laboratory numbers 23285-(39-41), were analyzed for permanent gases. Agreement between repeat analyses is a measure of precision and is shown above in the column "% RPD". The average % RPD for 4 repeat measurements from three Silco canister samples is 0.49%.





LABORATORY ANALYSIS REPORT

Permanent Gases Analysis in Silco Canister Samples by Method ASTM D1946-90

Report Date: December 2, 2025
Client: Montrose AQS
Project Location: Chiquita Landfill
Project No.: PROJ-061273
Date Received: November 24, 2025
Date Analyzed: December 1, 2025

ANALYSIS DESCRIPTION

Permanent gases were measured by thermal conductivity detection/gas chromatography (TCD/GC), ASTM D1946-90.

AtmAA Lab No.: 23285-42 23285-43
Sample I.D.: Flare Station Pre H2S | Flare Station Post H2S

<u>Components</u>	<i>(Concentration in %v)</i>	
Nitrogen	22.43	24.12
Oxygen	4.83	5.35
Methane	29.28	28.13
Carbon dioxide	38.03	36.87
Hydrogen	2.06	2.18

The reported oxygen concentration includes any argon present in the sample. Calibration is based on a standard atmosphere containing 20.95% oxygen and 0.93% argon. The accuracy of permanent gas analysis by TCD/GC is +/- 2%, actual results are reported. Actual analysis results are reported on a "wet" basis.



Brian W. Fung
Laboratory Director

QUALITY ASSURANCE SUMMARY
(Repeat Analyses)

Project Location: Chiquita Landfill
Date Received: November 24, 2025
Date Analyzed: December 1, 2025

Components	Sample ID	Repeat Analysis		Mean Conc.	% RPD
		Run #1	Run #2		
		<i>(Concentration in %v)</i>			
Nitrogen	Flare Station Pre H2S	22.47	22.38	22.43	0.40
Oxygen	Flare Station Pre H2S	4.85	4.80	4.83	1.0
Methane	Flare Station Pre H2S	29.30	29.25	29.28	0.17
Carbon dioxide	Flare Station Pre H2S	38.08	37.98	38.03	0.26
Hydrogen	Flare Station Pre H2S	2.07	2.05	2.06	0.97

Two Silco canister samples, laboratory numbers 23285-(42-43), were analyzed for permanent gases. Agreement between repeat analyses is a measure of precision and is shown above in the column "% RPD". The average % RPD for 5 repeat measurements from two Silco canister samples is 0.57%.





LABORATORY ANALYSIS REPORT

Speciated Hydrocarbons Analysis in Silco Canister Samples

Report Date: December 2, 2025
Client: Montrose AQS
Project Location: Chiquita Landfill
Project No.: PROJ-061273
Date Received: November 24, 2025
Date Analyzed: December 1, 2025
Laboratory Temp: 73.5 °F
Barometric Pressure: 29.97 inHg

ANALYSIS DESCRIPTION

Hydrocarbon speciation analysis was performed by flame ionization detection/gas chromatography (FID/GC), modified EPA-18. Methane was measured by thermal conductivity detection/gas chromatography (TCD/GC), ASTM D1946-90

AtmAA Lab No.:	23285-36	23285-37	23285-38
Sample ID:	Parnell Inlet	Zeeco Inlet	Hero Inlet

<u>Component</u>	<i>(Concentration in ppmv, component)</i>		
Methane	136500	164700	125200
Ethene	29.5	9.17	34.1
Acetylene	<0.30	<0.30	<0.30
Ethane	95.9	41.8	97.0

Non-methane hydrocarbons analysis by carbon number grouping

C3	307	176	335
C4	2023	441	1602
C5	1481	579	1567
C6	2012	530	1599
C7	628	208	635
C8	315	136	352
C9	384	166	384
C10	252	165	341
C11	38.4	38.2	58.2
C12	17.6	18.8	32.6
C13	5.79	9.49	14.4
C14	0.76	1.78	2.98

	<i>(Concentration in ppmvC)</i>		
TNMHC	42359	14955	40496

TNMHC - total non-methane hydrocarbons as ppmvC.
Actual analysis results are reported on a "wet" basis.

Brian W. Fung
Laboratory Director

QUALITY ASSURANCE SUMMARY
(Repeat Analyses)

Project Location: Chiquita Landfill
Date Received: November 24, 2025
Date Analyzed: December 1, 2025

Component	Sample ID	Repeat Analysis		Mean Conc.	% RPD
		Run #1	Run #2		
		<i>(Conc. in ppmv, component)</i>			
Methane	Parnell Inlet	136500	136500	136500	0.00
Ethene	Parnell Inlet	31.90	27.17	29.54	16
Acetylene	Parnell Inlet	<0.30	<0.30	<0.30	---
Ethane	Parnell Inlet	95.29	96.47	95.88	1.2
<u>non-methane hydrocarbons analysis by carbon number grouping</u>					
C3	Parnell Inlet	306	308	307	0.49
C4	Parnell Inlet	1973	2073	2023	4.9
C5	Parnell Inlet	1458	1504	1481	3.1
C6	Parnell Inlet	1981	2043	2012	3.1
C7	Parnell Inlet	625	631	628	0.84
C8	Parnell Inlet	315	315	315	0.10
C9	Parnell Inlet	387	382	384	1.3
C10	Parnell Inlet	254	250	252	1.7
C11	Parnell Inlet	38.2	38.7	38.4	1.3
C12	Parnell Inlet	17.6	17.6	17.6	0.00
C13	Parnell Inlet	5.61	5.98	5.79	6.3
C14	Parnell Inlet	0.74	0.77	0.76	3.8
<i>(Concentration in ppmvC)</i>					
TNMHC	Parnell Inlet	41880	42838	42359	2.3

Three Silco canister samples, laboratory numbers 23285-(36-38), were analyzed for hydrocarbon speciation, EPA Method 18. Agreement between repeat analyses is a measure of precision and is shown above in the column "% RPD". The average % RPD for 16 repeat measurements from three Silco canister samples is 2.9%.





LABORATORY ANALYSIS REPORT

Speciated Hydrocarbons Analysis in Silco Canister Samples

Report Date: December 2, 2025
Client: Montrose AQS
Project Location: Chiquita Landfill
Project No.: PROJ-061273
Date Received: November 24, 2025
Date Analyzed: December 1, 2025
Laboratory Temp: 73.5 °F
Barometric Pressure: 29.97 inHg

ANALYSIS DESCRIPTION

Hydrocarbon speciation analysis was performed by flame ionization detection/gas chromatography (FID/GC), modified EPA-18. Methane was measured by thermal conductivity detection/gas chromatography (TCD/GC), ASTM D1946-90

AtmAA Lab No.:	23285-39	23285-40	23285-41
Sample ID:	TF 7B	Canyon D	TF 13

Component	(Concentration in ppmv, component)		
Methane	255500	3532	355
Ethene	<0.30	<0.30	0.35
Acetylene	<0.30	<0.30	<0.30
Ethane	11.6	1.51	0.31

Non-methane hydrocarbons analysis by carbon number grouping

C3	85.7	35.1	1.46
C4	237	71.8	103
C5	693	32.4	118
C6	446	7.15	69.3
C7	117	7.56	16.3
C8	90.4	11.6	14.2
C9	111	32.5	15.1
C10	185	9.00	41.4
C11	45.7	7.11	14.5
C12	26.7	4.20	7.24
C13	16.7	1.50	4.68
C14	6.79	0.28	1.43

	(Concentration in ppmvC)		
TNMHC	12889	1281	2530

TNMHC - total non-methane hydrocarbons as ppmvC.
Actual analysis results are reported on a "wet" basis.

Brian W. Fung
Laboratory Director



LABORATORY ANALYSIS REPORT

Speciated Hydrocarbons Analysis in Silco Canister Samples

Report Date: December 2, 2025
Client: Montrose AQS
Project Location: Chiquita Landfill
Project No.: PROJ-061273
Date Received: November 24, 2025
Date Analyzed: December 1, 2025
Laboratory Temp: 73.5 °F
Barometric Pressure: 29.97 inHg

ANALYSIS DESCRIPTION

Hydrocarbon speciation analysis was performed by flame ionization detection/gas chromatography (FID/GC), modified EPA-18. Methane was measured by thermal conductivity detection/gas chromatography (TCD/GC), ASTM D1946-90

AtmAA Lab No.: 23285-42 23285-43
Sample ID: Flare Station Pre H2S | Flare Station Post H2S

Component	(Concentration in ppmv, component)	
Methane	292800	281300
Ethene	<0.30	<0.30
Acetylene	<0.30	<0.30
Ethane	39.3	38.1

Non-methane hydrocarbons analysis by carbon number grouping

C3	164	170
C4	911	448
C5	1153	717
C6	904	626
C7	234	219
C8	210	190
C9	254	229
C10	241	168
C11	52.2	37.8
C12	26.0	18.7
C13	11.9	9.59
C14	2.50	1.55

TNMHC (Concentration in ppmvC)
24483 17286

TNMHC - total non-methane hydrocarbons as ppmvC.
Actual analysis results are reported on a "wet" basis.

Brian W. Fung
Laboratory Director

QUALITY ASSURANCE SUMMARY
(Repeat Analyses)

Project Location: Chiquita Landfill
Date Received: November 24, 2025
Date Analyzed: December 1, 2025

Component	Sample ID	Repeat Analysis		Mean Conc.	% RPD
		Run #1	Run #2		
		<i>(Conc. in ppmv, component)</i>			
Methane	Flare Station Pre H2S	293000	292500	292750	0.17
Ethene	Flare Station Pre H2S	<0.30	<0.30	<0.30	---
Acetylene	Flare Station Pre H2S	<0.30	<0.30	<0.30	---
Ethane	Flare Station Pre H2S	39.1	39.4	39.3	0.74
<u>non-methane hydrocarbons analysis by carbon number grouping</u>					
C3	Flare Station Pre H2S	161	166	164	2.9
C4	Flare Station Pre H2S	917	904	911	1.4
C5	Flare Station Pre H2S	1163	1143	1153	1.7
C6	Flare Station Pre H2S	912	896	904	1.8
C7	Flare Station Pre H2S	237	231	234	2.6
C8	Flare Station Pre H2S	212	208	210	2.1
C9	Flare Station Pre H2S	259	249	254	3.9
C10	Flare Station Pre H2S	248	234	241	5.8
C11	Flare Station Pre H2S	52.8	51.7	52.2	2.1
C12	Flare Station Pre H2S	26.6	25.3	26.0	5.0
C13	Flare Station Pre H2S	12.1	11.6	11.9	3.9
C14	Flare Station Pre H2S	2.20	2.80	2.50	24
		<i>(Concentration in ppmvC)</i>			
TNMHC	Flare Station Pre H2S	24765	24201	24483	2.3

Two Silco canister samples, laboratory numbers 23285-(42-43), were analyzed for hydrocarbon speciation, EPA Method 18. Agreement between repeat analyses is a measure of precision and is shown above in the column "% RPD". The average % RPD for 15 repeat measurements from two Silco canister samples is 4.0%.



Calculated values for Specific Volume, BTU, and F (factor)

Report Date: December 2, 2025
 Client: Montrose AQS
 Project Location: Chiquita Landfill
 Date Received: November 24, 2025
 Date Analyzed: December 1, 2025
 AtmAA Lab #: 23285-36
 Sample ID: Parnell Inlet

Specific volume, BTU, and F-factor are calculated using normalized laboratory analysis results for methane, carbon dioxide, nitrogen, oxygen, TNMHC, and sulfur compounds in equations that include gross/net heating and specific gas volume values taken from the GPA-2145 Midstream Standard. Heating value factor is a calculated according to ASTM 3588-98 (14.696 psia and 60°F). The F-factor is calculated according to the equation in EPA Method 19.

Component	Mole %	Wt %	C,H,O,N,S, Wt.%	
Methane	14.14	6.94	Carbon	22.20
Carbon dioxide	41.90	56.43	Hydrogen	2.32
Nitrogen	31.48	26.99	Oxygen	48.07
Oxygen	7.19	7.04	Nitrogen	26.99
Argon	0.32	0.39	Argon	0.39
Hydrogen	4.17	0.26	Sulfur	0.01
(CH ₂) _n	0.787	1.93		
Specific Volume		11.610		
BTU/ft ³ (Dry @60F, 14.696 psia)		191.3	(HHV)	172.4 (LHV)
BTU/ft ³ (Water Saturated @ 0.25636 psia)		188.0	(HHV)	169.4 (LHV)
BTU/lb (Dry @60F, 14.696 psia)		2221	(HHV)	2002 (LHV)
F _d (factor)		10842		
F _w (factor)		12859		
F _c (factor)		3207		
Compressibility Factor (@60F, 14.696 psia)		0.9977		
Wobbe Index		180.48		
Specific Gravity		1.1239		

Component	Specific volume reference values *
Methane	23.7 (ft ³ /lb)
Carbon dioxide	8.62
Nitrogen	13.5
Oxygen	11.9
Argon	9.52
Hydrogen	188.2

* reference, Rev. 2016, GPA-2145 Midstream Standard, Selected Hydrocarbons 60°F



Calculated values for Specific Volume, BTU, and F (factor)

Report Date: December 2, 2025
 Client: Montrose AQS
 Project Location: Chiquita Landfill
 Date Received: November 24, 2025
 Date Analyzed: December 1, 2025
 AtmAA Lab #: 23285-37
 Sample ID: Zeeco Inlet

Specific volume, BTU, and F-factor are calculated using normalized laboratory analysis results for methane, carbon dioxide, nitrogen, oxygen, TNMHC, and sulfur compounds in equations that include gross/net heating and specific gas volume values taken from the GPA-2145 Midstream Standard. Heating value factor is a calculated according to ASTM 3588-98 (14.696 psia and 60°F). The F-factor is calculated according to the equation in EPA Method 19.

Component	Mole %	Wt %	C,H,O,N,S, Wt.%	
Methane	16.94	8.71	Carbon	19.17
Carbon dioxide	31.27	44.19	Hydrogen	2.38
Nitrogen	41.00	36.87	Oxygen	41.07
Oxygen	8.70	8.94	Nitrogen	36.87
Argon	0.39	0.50	Argon	0.50
Hydrogen (CH ₂) _n	1.44	0.09	Sulfur	0.01
	0.259	0.71		
Specific Volume		12.172		
BTU/ft ³ (Dry @60F, 14.696 psia)		188.0	(HHV)	169.4 (LHV)
BTU/ft ³ (Water Saturated @ 0.25636 psia)		184.8	(HHV)	166.4 (LHV)
BTU/lb (Dry @60F, 14.696 psia)		2289	(HHV)	2062 (LHV)
F _d (factor)		10612		
F _w (factor)		12623		
F _c (factor)		2689		
Compressibility Factor (@60F, 14.696 psia)		0.9983		
Wobbe Index		181.7		
Specific Gravity		1.0713		

Component	Specific volume reference values *
Methane	23.7 (ft ³ /lb)
Carbon dioxide	8.62
Nitrogen	13.5
Oxygen	11.9
Argon	9.52
Hydrogen	188.2

* reference, Rev. 2016, GPA-2145 Midstream Standard, Selected Hydrocarbons 60°F



Calculated values for Specific Volume, BTU, and F (factor)

Report Date: December 2, 2025
 Client: Montrose AQS
 Project Location: Chiquita Landfill
 Date Received: November 24, 2025
 Date Analyzed: December 1, 2025
 AtmAA Lab #: 23285-38
 Sample ID: Hero Inlet

Specific volume, BTU, and F-factor are calculated using normalized laboratory analysis results for methane, carbon dioxide, nitrogen, oxygen, TNMHC, and sulfur compounds in equations that include gross/net heating and specific gas volume values taken from the GPA-2145 Midstream Standard. Heating value factor is a calculated according to ASTM 3588-98 (14.696 psia and 60°F). The F-factor is calculated according to the equation in EPA Method 19.

Component	Mole %	Wt %	C,H,O,N,S, Wt. %	
Methane	13.01	6.37	Carbon	21.84
Carbon dioxide	42.24	56.91	Hydrogen	2.19
Nitrogen	31.63	27.11	Oxygen	48.45
Oxygen	7.21	7.06	Nitrogen	27.11
Argon	0.32	0.39	Argon	0.39
Hydrogen (CH ₂) _n	4.85 0.733	0.30 1.85	Sulfur	0.01
Specific Volume		11.604		
BTU/ft3 (Dry @60F, 14.696 psia)		180.6	(HHV)	162.6 (LHV)
BTU/ft3 (Water Saturated @ 0.25636 psia)		177.4	(HHV)	159.7 (LHV)
BTU/lb (Dry @60F, 14.696 psia)		2095	(HHV)	1886 (LHV)
F _d (factor)		10939		
F _w (factor)		12959		
F _c (factor)		3346		
Compressibility Factor (@60F, 14.696 psia)		0.9978		
Wobbe Index		170.2		
Specific Gravity		1.1256		

Component	Specific volume reference values *
Methane	23.7 (ft ³ /lb)
Carbon dioxide	8.62
Nitrogen	13.5
Oxygen	11.9
Argon	9.52
Hydrogen	188.2

* reference, Rev. 2016, GPA-2145 Midstream Standard, Selected Hydrocarbons 60°F



Calculated values for Specific Volume, BTU, and F (factor)

Report Date: December 2, 2025
 Client: Montrose AQS
 Project Location: Chiquita Landfill
 Date Received: November 24, 2025
 Date Analyzed: December 1, 2025
 AtmAA Lab #: 23285-39
 Sample ID: TF 7B

Specific volume, BTU, and F-factor are calculated using normalized laboratory analysis results for methane, carbon dioxide, nitrogen, oxygen, TNMHC, and sulfur compounds in equations that include gross/net heating and specific gas volume values taken from the GPA-2145 Midstream Standard. Heating value factor is a calculated according to ASTM 3588-98 (14.696 psia and 60°F). The F-factor is calculated according to the equation in EPA Method 19.

Component	Mole %	Wt %	C,H,O,N,S, Wt.%	
Methane	26.44	14.33	Carbon	22.05
Carbon dioxide	27.25	40.54	Hydrogen	3.67
Nitrogen	37.41	35.42	Oxygen	38.34
Oxygen	8.20	8.86	Nitrogen	35.42
Argon	0.36	0.49	Argon	0.49
Hydrogen	0.22	0.01	Sulfur	0.02
(CH ₂) _n	0.107	0.32		
Specific Volume		12.821		
BTU/ft3 (Dry @60F, 14.696 psia)		273.1	(HHV)	246.0 (LHV)
BTU/ft3 (Water Saturated @ 0.25636 psia)		268.3	(HHV)	241.7 (LHV)
BTU/lb (Dry @60F, 14.696 psia)		3502	(HHV)	3154 (LHV)
F _d (factor)		9833		
F _w (factor)		11857		
F _c (factor)		2021		
Compressibility Factor (@60F, 14.696 psia)		0.9983		
Wobbe Index		270.59		
Specific Gravity		1.0187		

Component	Specific volume reference values *
Methane	23.7 (ft ³ /lb)
Carbon dioxide	8.62
Nitrogen	13.5
Oxygen	11.9
Argon	9.52
Hydrogen	188.2

* reference, Rev. 2016, GPA-2145 Midstream Standard, Selected Hydrocarbons 60°F



Calculated values for Specific Volume, BTU, and F (factor)

Report Date: December 2, 2025
 Client: Montrose AQS
 Project Location: Chiquita Landfill
 Date Received: November 24, 2025
 Date Analyzed: December 1, 2025
 AtmAA Lab #: 23285-40
 Sample ID: Canyon D

Specific volume, BTU, and F-factor are calculated using normalized laboratory analysis results for methane, carbon dioxide, nitrogen, oxygen, TNMHC, and sulfur compounds in equations that include gross/net heating and specific gas volume values taken from the GPA-2145 Midstream Standard. Heating value factor is a calculated according to ASTM 3588-98 (14.696 psia and 60°F). The F-factor is calculated according to the equation in EPA Method 19.

Component	Mole %	Wt %	C,H,O,N,S, Wt. %	
Methane	0.000	0.000	Carbon	0.30
Carbon dioxide	0.59	0.89	Hydrogen	0.01
Nitrogen	77.61	74.80	Oxygen	23.62
Oxygen	20.86	22.98	Nitrogen	74.80
Argon	0.93	1.27	Argon	1.27
Hydrogen	0.00	0.00	Sulfur	0.00
(CH ₂) _n	0.023	0.06		
Specific Volume		13.051		
BTU/ft3 (Dry @60F, 14.696 psia)		1.037	(HHV)	0.9601 (LHV)
BTU/ft3 (Water Saturated @ 0.25636 psia)		1.019	(HHV)	0.9434 (LHV)
BTU/lb (Dry @60F, 14.696 psia)		13.536	(HHV)	12.53 (LHV)
F _d (factor)		7168		
F _w (factor)		8673		
F _c (factor)		7024		
Compressibility Factor (@60F, 14.696 psia)		0.9996		
Wobbe Index		1.042		
Specific Gravity		0.9905		

Component	Specific volume reference values *
Methane	23.7 (ft ³ /lb)
Carbon dioxide	8.62
Nitrogen	13.5
Oxygen	11.9
Argon	9.52
Hydrogen	188.2

* reference, Rev. 2016, GPA-2145 Midstream Standard, Selected Hydrocarbons 60°F



Calculated values for Specific Volume, BTU, and F (factor)

Report Date: December 2, 2025
 Client: Montrose AQS
 Project Location: Chiquita Landfill
 Date Received: November 24, 2025
 Date Analyzed: December 1, 2025
 AtmAA Lab #: 23285-41
 Sample ID: TF 13

Specific volume, BTU, and F-factor are calculated using normalized laboratory analysis results for methane, carbon dioxide, nitrogen, oxygen, TNMHC, and sulfur compounds in equations that include gross/net heating and specific gas volume values taken from the GPA-2145 Midstream Standard. Heating value factor is a calculated according to ASTM 3588-98 (14.696 psia and 60°F). The F-factor is calculated according to the equation in EPA Method 19.

Component	Mole %	Wt %	C,H,O,N,S, Wt.%		
Methane	0.00	0.000	Carbon	0.45	
Carbon dioxide	0.83	1.26	Hydrogen	0.02	
Nitrogen	77.39	74.46	Oxygen	23.80	
Oxygen	20.81	22.89	Nitrogen	74.46	
Argon	0.92	1.27	Argon	1.27	
Hydrogen	0.00	0.00	Sulfur	0.00	
(CH ₂) _n	0.042	0.13			
Specific Volume		13.029			
BTU/ft3 (Dry @60F, 14.696 psia)		2.041	(HHV)	1.890	(LHV)
BTU/ft3 (Water Saturated @ 0.25636 psia)		2.005	(HHV)	1.857	(LHV)
BTU/lb (Dry @60F, 14.696 psia)		26.59	(HHV)	24.63	(LHV)
F _d (factor)		8987			
F _w (factor)		10483			
F _c (factor)		5427			
Compressibility Factor (@60F, 14.696 psia)		0.9996			
Wobbe Index		2.048			
Specific Gravity		0.9931			

Component	Specific volume reference values *
Methane	23.7 (ft ³ /lb)
Carbon dioxide	8.62
Nitrogen	13.5
Oxygen	11.9
Argon	9.52
Hydrogen	188.2

* reference, Rev. 2016, GPA-2145 Midstream Standard, Selected Hydrocarbons 60°F



Calculated values for Specific Volume, BTU, and F (factor)

Report Date: December 2, 2025
 Client: Montrose AQS
 Project Location: Chiquita Landfill
 Date Received: November 24, 2025
 Date Analyzed: December 1, 2025
 AtmAA Lab #: 23285-42
 Sample ID: Flare Station Pre H2S

Specific volume, BTU, and F-factor are calculated using normalized laboratory analysis results for methane, carbon dioxide, nitrogen, oxygen, TNMHC, and sulfur compounds in equations that include gross/net heating and specific gas volume values taken from the GPA-2145 Midstream Standard. Heating value factor is a calculated according to ASTM 3588-98 (14.696 psia and 60°F). The F-factor is calculated according to the equation in EPA Method 19.

Component	Mole %	Wt %	C,H,O,N,S, Wt.%	
Methane	30.16	15.83	Carbon	28.21
Carbon dioxide	39.18	56.40	Hydrogen	4.31
Nitrogen	23.10	21.17	Oxygen	45.99
Oxygen	4.76	4.98	Nitrogen	21.17
Argon	0.21	0.28	Argon	0.28
Hydrogen	2.12	0.14	Sulfur	0.03
(CH ₂) _n	0.433	1.19		
Specific Volume		12.408		
BTU/ft ³ (Dry @60F, 14.696 psia)		331.7	(HHV)	298.8 (LHV)
BTU/ft ³ (Water Saturated @ 0.25636 psia)		325.9	(HHV)	293.6 (LHV)
BTU/lb (Dry @60F, 14.696 psia)		4116	(HHV)	3707 (LHV)
F _d (factor)		9886		
F _w (factor)		11909		
F _c (factor)		2200		
Compressibility Factor (@60F, 14.696 psia)		0.9975		
Wobbe Index		323.04		
Specific Gravity		1.0542		

Component	Specific volume reference values *
Methane	23.7 (ft ³ /lb)
Carbon dioxide	8.62
Nitrogen	13.5
Oxygen	11.9
Argon	9.52
Hydrogen	188.2

* reference, Rev. 2016, GPA-2145 Midstream Standard, Selected Hydrocarbons 60°F



Calculated values for Specific Volume, BTU, and F (factor)

Report Date: December 2, 2025
 Client: Montrose AQS
 Project Location: Chiquita Landfill
 Date Received: November 24, 2025
 Date Analyzed: December 1, 2025
 AtmAA Lab #: 23285-43
 Sample ID: Flare Station Post H2S

Specific volume, BTU, and F-factor are calculated using normalized laboratory analysis results for methane, carbon dioxide, nitrogen, oxygen, TNMHC, and sulfur compounds in equations that include gross/net heating and specific gas volume values taken from the GPA-2145 Midstream Standard. Heating value factor is a calculated according to ASTM 3588-98 (14.696 psia and 60°F). The F-factor is calculated according to the equation in EPA Method 19.

Component	Mole %	Wt %	C,H,O,N,S, Wt. %	
Methane	29.02	15.26	Carbon	27.15
Carbon dioxide	38.03	55.00	Hydrogen	4.10
Nitrogen	24.88	22.89	Oxygen	45.55
Oxygen	5.28	5.55	Nitrogen	22.89
Argon	0.23	0.31	Argon	0.31
Hydrogen	2.25	0.15	Sulfur	0.00
(CH ₂) _n	0.296	0.84		
Specific Volume		12.453		
BTU/ft3 (Dry @60F, 14.696 psia)		314.6	(HHV)	283.2 (LHV)
BTU/ft3 (Water Saturated @ 0.25636 psia)		309.1	(HHV)	278.2 (LHV)
BTU/lb (Dry @60F, 14.696 psia)		3917	(HHV)	3527 (LHV)
F _a (factor)		9882		
F _w (factor)		11902		
F _c (factor)		2225		
Compressibility Factor (@60F, 14.696 psia)		0.9977		
Wobbe Index		307.1		
Specific Gravity		1.0489		

Component	Specific volume reference values *
Methane	23.7 (ft ³ /lb)
Carbon dioxide	8.62
Nitrogen	13.5
Oxygen	11.9
Argon	9.52
Hydrogen	188.2

* reference, Rev. 2016, GPA-2145 Midstream Standard, Selected Hydrocarbons 60°F





LABORATORY ANALYSIS REPORT

SCAQMD Rule 1150.1 Components Analysis in Silco Canister Samples

Report Date: December 2, 2025
Client: Montrose AQS
Project Name: MAQS Chiquita 4th Qtr
Project Location: Chiquita Landfill
Project No.: PROJ-061273
Date Received: November 24, 2025
Date Analyzed: November 24, 2025

AtmAA Lab No.:	23285-36	23285-37	23285-38
Sample I.D.:	Parnell Inlet	Zeeco Inlet	Hero Inlet

(Concentration in ppbv)

Components

Hydrogen sulfide	133000	106500	139500
Benzene	158000	52600	180000
Benzyl chloride	<4500	<4500	<4500
Chlorobenzene	<4500	<4500	<4500
Dichlorobenzenes*	<6500	<6500	<6500
1,1-dichloroethane	<5000	<5000	<5000
1,2-dichloroethane	<5000	<5000	<5000
1,1-dichloroethylene	<5000	<5000	<5000
Dichloromethane	<11000	<11000	<11000
1,2-dibromoethane	<3000	<3000	<3000
Perchloroethylene	<3000	<3000	<3000
Carbon tetrachloride	<4000	<4000	<4000
Toluene	13750	5460	14900
1,1,1-trichloroethane	<4000	<4000	<4000
Trichloroethene	<4000	<4000	<4000
Chloroform	<4000	<4000	<4000
Vinyl chloride	<4000	<4000	<4000
m+p-xylenes	5865	<4500	5780
o-xylene	<4500	<4500	<4500

Toxic air contaminants (TAC) compounds were analyzed by GC/MS, EPA TO-15.

Hydrogen sulfide was analyzed by SCD/GC, SCAQMD 307.91.

* total amount containing meta, para, and ortho isomers



Brian W. Fung
Laboratory Director



AtmAA Inc.

5107 Douglas Fir Rd., Calabasas, CA 91302 • (818) 223-3277

specialized air assessment laboratory
atmaa.com

LABORATORY ANALYSIS REPORT

SCAQMD Rule 1150.1 Components Analysis in Silco Canister Samples

Report Date: December 2, 2025
Client: Montrose AQS
Project Name: MAQS Chiquita 4th Qtr
Project Location: Chiquita Landfill
Project No.: PROJ-061273
Date Received: November 24, 2025
Date Analyzed: November 24, 2025

AtmAA Lab No.:	23285-39	23285-40	23285-41
Sample I.D.:	TF 7B	Canyon D	TF 13

(Concentration in ppbv)

Components

Hydrogen sulfide	181000	235	<80
Benzene	12000	706	2470
Benzyl chloride	<45	<45	<45
Chlorobenzene	<40	<40	<40
Dichlorobenzenes*	<80	<80	<80
1,1-dichloroethane	<50	<50	<50
1,2-dichloroethane	343	343	343
1,1-dichloroethylene	<50	<50	<50
Dichloromethane	<110	<110	<110
1,2-dibromoethane	<30	<30	<30
Perchloroethylene	62.0	<30	<30
Carbon tetrachloride	<60	<60	<60
Toluene	2130	227	266
1,1,1-trichloroethane	<35	<35	<35
Trichloroethene	42.6	<35	<35
Chloroform	<40	<40	<40
Vinyl chloride	<40	<40	<40
m+p-xylenes	608	66.9	84.7
o-xylene	159	<45	<45

Toxic air contaminants (TAC) compounds were analyzed by GC/MS, EPA TO-15.

Hydrogen sulfide was analyzed by SCD/GC, SCAQMD 307.91.

* total amount containing meta, para, and ortho isomers



Brian W. Fung
Laboratory Director



LABORATORY ANALYSIS REPORT

SCAQMD Rule 1150.1 Components Analysis in Silco Canister Samples

Report Date: December 2, 2025
Client: Montrose AQS
Project Name: MAQS Chiquita 4th Qtr
Project Location: Chiquita Landfill
Project No.: PROJ-061273
Date Received: November 24, 2025
Date Analyzed: November 24, 2025

AtmAA Lab No.: 23285-42 23285-43
Sample I.D.: Flare Station Pre H2S | Flare Station Post H2S
(Concentration in ppbv)

Components

Hydrogen sulfide	244000	9386
Benzene	81400	45900
Benzyl chloride	<4500	<4500
Chlorobenzene	<4500	<4500
Dichlorobenzenes*	<6500	<6500
1,1-dichloroethane	<5000	<5000
1,2-dichloroethane	<5000	<5000
1,1-dichloroethylene	<5000	<5000
Dichloromethane	<11000	<11000
1,2-dibromoethane	<3000	<3000
Perchloroethylene	<3000	<3000
Carbon tetrachloride	<4000	<4000
Toluene	12700	7240
1,1,1-trichloroethane	<4000	<4000
Trichloroethene	<4000	<4000
Chloroform	<4000	<4000
Vinyl chloride	<4000	<4000
m+p-xylenes	<4500	<4500
o-xylene	<4500	<4500

Toxic air contaminants (TAC) compounds were analyzed by GC/MS, EPA TO-15.

Hydrogen sulfide was analyzed by SCD/GC, SCAQMD 307.91.

* total amount containing meta, para, and ortho isomers



Brian W. Fung
Laboratory Director

QUALITY ASSURANCE SUMMARY
(Repeat Analyses)

Project Name: MAQS Chiquita 4th Qtr
Date Received: November 24, 2025
Date Analyzed: November 24, 2025

Components	Sample ID	Repeat Analysis		Mean Conc.	% RPD
		Run #1	Run #2		
		(Concentration in ppbv)			
Hydrogen sulfide	Parnell Inlet	138000	128000	133000	7.5
Benzene	Parnell Inlet	156000	160000	158000	2.5
Benzyl chloride	Parnell Inlet	<4500	<4500	---	---
Chlorobenzene	Parnell Inlet	<4500	<4500	---	---
Dichlorobenzenes	Parnell Inlet	<6500	<6500	---	---
1,1-dichloroethane	Parnell Inlet	<5000	<5000	---	---
1,2-dichloroethane	Parnell Inlet	<5000	<5000	---	---
1,1-dichloroethylene	Parnell Inlet	<5000	<5000	---	---
Dichloromethane	Parnell Inlet	<11000	<11000	---	---
1,2-dibromoethane	Parnell Inlet	<3000	<3000	---	---
Perchloroethylene	Parnell Inlet	<3000	<3000	---	---
Carbon tetrachloride	Parnell Inlet	<4000	<4000	---	---
Toluene	Parnell Inlet	13600	13900	13750	2.2
1,1,1-trichloroethane	Parnell Inlet	<4000	<4000	---	---
Trichloroethene	Parnell Inlet	<4000	<4000	---	---
Chloroform	Parnell Inlet	<4000	<4000	---	---
Vinyl chloride	Parnell Inlet	<4000	<4000	---	---
m+p-xylenes	Parnell Inlet	5750	5980	5865	3.9
o-xylene	Parnell Inlet	<4500	<4500	---	---

Eight Silco canister samples, laboratory numbers 23285-(36-43), were analyzed for SCAQMD Rule 1150.1 components. Agreement between repeat analyses is a measure of precision and is shown above in the column "% RPD". The average % RPD for 4 repeat measurements from eight Silco canister samples is 4.0%.





LABORATORY ANALYSIS REPORT

Hydrogen Sulfide and Reduced Sulfur Compounds
Analysis in Silco Canister Sample by SCAQMD Method 307.91

Report Date: December 2, 2025
Client: Montrose AQS
Project Name: MAQS Chiquita 4th Qtr
Project Location: Chiquita Landfill
Project No.: PROJ-061273
Date Received: November 24, 2025
Date Analyzed: November 24, 2025

ANALYSIS DESCRIPTION

Total sulfur analysis measured by gas chromatography with sulfur chemiluminescence detector (SCD), SCAQMD 307.91.

AtmAA Lab No.:	23285-36	23285-37	23285-38
Sample I.D.:	Parnell Inlet	Zeeco Inlet	Hero Inlet
Components	(Concentration in ppmv)		
Hydrogen sulfide	133	107	140
Carbonyl sulfide	<1.50	<1.00	<1.50
Methyl mercaptan	258	82.7	303
Ethyl mercaptan	3.18	1.53	3.60
Dimethyl sulfide	828	315	963
Carbon disulfide	<1.50	<1.00	<1.50
i-Propyl mercaptan	2.22	1.03	2.38
t-Butyl mercaptan	<1.50	<1.00	<1.50
n-Propyl mercaptan	11.3	4.58	12.6
s-Butyl mercaptan	10.8	3.78	12.1
i-Butyl mercaptan	<1.50	<1.00	<1.50
Dimethyl disulfide	7.51	1.99	7.22
Tetrahydrothiophene	6.67	1.60	7.30
Unidentified sulfurs	24.0	5.91	23.8
(Concentration in ppmv, as H ₂ S)			
Total Sulfur	1291.09	526.54	1481.11

Brian W. Fung
Laboratory Director



LABORATORY ANALYSIS REPORT

Hydrogen Sulfide and Reduced Sulfur Compounds
Analysis in Silco Canister Sample by SCAQMD Method 307.91

Report Date: December 2, 2025
Client: Montrose AQS
Project Name: MAQS Chiquita 4th Qtr
Project Location: Chiquita Landfill
Project No.: PROJ-061273
Date Received: November 24, 2025
Date Analyzed: November 24, 2025

ANALYSIS DESCRIPTION

Total sulfur analysis measured by gas chromatography with sulfur chemiluminescence detector (SCD), SCAQMD 307.91.

AtmAA Lab No.:	23285-39	23285-40	23285-41
Sample I.D.:	TF 7B	Canyon D	TF 13
Components	(Concentration in ppmv)		
Hydrogen sulfide	181	0.24	<0.08
Carbonyl sulfide	1.01	<0.08	<0.08
Methyl mercaptan	24.3	0.35	0.28
Ethyl mercaptan	0.40	<0.08	<0.08
Dimethyl sulfide	70.2	1.90	14.1
Carbon disulfide	<0.30	<0.08	<0.08
i-Propyl mercaptan	2.91	<0.08	<0.08
t-Butyl mercaptan	<0.30	<0.08	<0.08
n-Propyl mercaptan	1.06	<0.08	0.15
s-Butyl mercaptan	3.39	<0.08	0.09
i-Butyl mercaptan	<0.30	<0.08	<0.08
Dimethyl disulfide	<0.30	<0.08	<0.08
Tetrahydrothiophene	0.37	<0.08	0.09
Unidentified sulfurs	1.69	0.23	0.09
	(Concentration in ppmv, as H ₂ S)		
Total Sulfur	286.26	2.71	14.74



Brian W. Fung
Laboratory Director



LABORATORY ANALYSIS REPORT

Hydrogen Sulfide and Reduced Sulfur Compounds
Analysis in Silco Canister Sample by SCAQMD Method 307.91

Report Date: December 2, 2025
Client: Montrose AQS
Project Name: MAQS Chiquita 4th Qtr
Project Location: Chiquita Landfill
Project No.: PROJ-061273
Date Received: November 24, 2025
Date Analyzed: November 24, 2025

ANALYSIS DESCRIPTION

Total sulfur analysis measured by gas chromatography with sulfur chemiluminescence detector (SCD), SCAQMD 307.91.

Components	AtmAA Lab No.: 23285-42	23285-43
	Sample I.D.: Flare Station Pre H2S	Flare Station Post H2S
	<i>(Concentration in ppmv)</i>	
Hydrogen sulfide	244	27.7
Carbonyl sulfide	0.95	0.90
Methyl mercaptan	82.1	37.5
Ethyl mercaptan	1.22	<0.80
Dimethyl sulfide	291	278
Carbon disulfide	<1.00	<0.80
i-Propyl mercaptan	2.71	1.69
t-Butyl mercaptan	<1.00	<0.80
n-Propyl mercaptan	3.97	3.47
s-Butyl mercaptan	5.36	3.81
i-Butyl mercaptan	<1.00	<0.80
Dimethyl disulfide	2.78	8.29
Tetrahydrothiophene	2.22	1.71
Unidentified sulfurs	10.5	22.3

(Concentration in ppmv, as H₂S)

Total Sulfur	649.48	393.05
--------------	--------	--------

 Brian W. Fung
 Laboratory Director

QUALITY ASSURANCE SUMMARY
(Repeat Analyses)

Project Name: MAQS Chiquita 4th Qtr
Date Received: November 24, 2025
Date Analyzed: November 24, 2025

Components	Sample ID	Repeat Analysis		Mean Conc.	% RPD
		Run #1	Run #2		
(Concentration in ppmv)					
Hydrogen sulfide	Parnell Inlet	138	128	133	7.5
	Zeeco Inlet	105	108	107	2.8
	Hero Inlet	140	139	140	0.72
	TF 7B	180	182	181	1.1
	Canyon D	0.23	0.24	0.24	4.3
	TF 13	<0.08	<0.08	---	---
	Flare Station Pre H2S	255	233	244	9.0
	Flare Station Post H2S	26.4	29.0	27.7	9.4
Carbonyl sulfide	Parnell Inlet	<1.50	<1.50	---	---
	Zeeco Inlet	<1.00	<1.00	---	---
	Hero Inlet	<1.50	<1.50	---	---
	TF 7B	1.00	1.02	1.01	2.0
	Canyon D	<0.08	<0.08	---	---
	TF 13	<0.08	<0.08	---	---
	Flare Station Pre H2S	1.02	0.88	0.95	15
	Flare Station Post H2S	0.84	0.95	0.90	12
Methyl mercaptan	Parnell Inlet	263	252	258	4.3
	Zeeco Inlet	81.5	83.8	82.7	2.8
	Hero Inlet	306	300	303	2.0
	TF 7B	24.0	24.5	24.3	2.1
	Canyon D	0.34	0.36	0.35	5.7
	TF 13	0.280	0.28	0.28	0.00
	Flare Station Pre H2S	86.5	77.6	82.1	11
	Flare Station Post H2S	35.9	39.0	37.5	8.3
Ethyl mercaptan	Parnell Inlet	3.16	3.20	3.18	1.3
	Zeeco Inlet	1.48	1.58	1.53	6.5
	Hero Inlet	3.58	3.62	3.60	1.1
	TF 7B	0.40	0.39	0.40	2.5
	Canyon D	<0.08	<0.08	---	---
	TF 13	<0.08	<0.08	---	---
	Flare Station Pre H2S	1.27	1.17	1.22	8.2
	Flare Station Post H2S	<0.80	<0.80	---	---
Dimethyl sulfide	Parnell Inlet	846	809	828	4.5
	Zeeco Inlet	310	320	315	3.2
	Hero Inlet	975	950	963	2.6
	TF 7B	69.5	70.9	70.2	2.0
	Canyon D	1.86	1.93	1.90	3.7
	TF 13	14.1	14.0	14.1	0.71
	Flare Station Pre H2S	306	276	291	10
	Flare Station Post H2S	265	290	278	9.0



QUALITY ASSURANCE SUMMARY
(Repeat Analyses)
(continued)

Components	Sample ID	Repeat Analysis		Mean Conc.	% RPD
		Run #1	Run #2		
(Concentration in ppmv)					
Carbon disulfide	Parnell Inlet	<1.50	<1.50	---	---
	Zeeco Inlet	<1.00	<1.00	---	---
	Hero Inlet	<1.50	<1.50	---	---
	TF 7B	<0.30	<0.30	---	---
	Canyon D	<0.08	<0.08	---	---
	TF 13	<0.08	<0.08	---	---
	Flare Station Pre H2S	<1.00	<1.00	---	---
	Flare Station Post H2S	<0.80	<0.80	---	---
i-Propyl mercaptan	Parnell Inlet	2.22	2.22	2.22	0.00
	Zeeco Inlet	0.97	1.09	1.03	12
	Hero Inlet	2.23	2.53	2.38	13
	TF 7B	2.87	2.94	2.91	2.4
	Canyon D	<0.08	<0.08	---	---
	TF 13	<0.08	<0.08	---	---
	Flare Station Pre H2S	2.88	2.54	2.71	13
	Flare Station Post H2S	1.61	1.77	1.69	9.5
t-Butyl mercaptan	Parnell Inlet	<1.50	<1.50	---	---
	Zeeco Inlet	<1.00	<1.00	---	---
	Hero Inlet	<1.50	<1.50	---	---
	TF 7B	<0.30	<0.30	---	---
	Canyon D	<0.08	<0.08	---	---
	TF 13	<0.08	<0.08	---	---
	Flare Station Pre H2S	<1.00	<1.00	---	---
	Flare Station Post H2S	<0.80	<0.80	---	---
n-Propyl mercaptan	Parnell Inlet	11.6	11.0	11.3	5.3
	Zeeco Inlet	4.55	4.60	4.58	1.1
	Hero Inlet	12.6	12.5	12.6	0.80
	TF 7B	1.04	1.07	1.06	2.8
	Canyon D	<0.08	<0.08	---	---
	TF 13	0.15	0.15	0.15	0.00
	Flare Station Pre H2S	4.14	3.80	3.97	8.6
	Flare Station Post H2S	3.39	3.54	3.47	4.3
s-Butyl mercaptan	Parnell Inlet	11.1	10.4	10.8	6.5
	Zeeco Inlet	3.82	3.74	3.78	2.1
	Hero Inlet	12.1	12.1	12.1	0.00
	TF 7B	3.33	3.45	3.39	3.5
	Canyon D	<0.08	<0.08	---	---
	TF 13	0.09	0.08	0.09	12
	Flare Station Pre H2S	5.52	5.20	5.36	6.0
	Flare Station Post H2S	3.69	3.92	3.81	6.0





QUALITY ASSURANCE SUMMARY
(Repeat Analyses)
(continued)

Components	Sample ID	Repeat Analysis		Mean Conc.	% RPD
		Run #1	Run #2		
(Concentration in ppmv)					
i-Butyl mercaptan	Parnell Inlet	<1.50	<1.50	---	---
	Zeeco Inlet	<1.00	<1.00	---	---
	Hero Inlet	<1.50	<1.50	---	---
	TF 7B	<0.30	<0.30	---	---
	Canyon D	<0.08	<0.08	---	---
	TF 13	<0.08	<0.08	---	---
	Flare Station Pre H2S	<1.00	<1.00	---	---
	Flare Station Post H2S	<0.80	<0.80	---	---
Dimethyl disulfide	Parnell Inlet	7.60	7.42	7.51	2.4
	Zeeco Inlet	1.98	1.99	1.99	0.50
	Hero Inlet	7.28	7.15	7.22	1.8
	TF 7B	<0.30	<0.30	---	---
	Canyon D	<0.08	<0.08	---	---
	TF 13	<0.08	<0.08	---	---
	Flare Station Pre H2S	2.88	2.67	2.78	7.6
	Flare Station Post H2S	7.92	8.66	8.29	8.9
Tetrahydrothiophene	Parnell Inlet	7.04	6.30	6.67	11
	Zeeco Inlet	1.62	1.57	1.60	3.1
	Hero Inlet	7.48	7.11	7.30	5.1
	TF 7B	0.36	0.38	0.37	5.4
	Canyon D	<0.08	<0.08	---	---
	TF 13	0.09	0.09	0.09	0.00
	Flare Station Pre H2S	2.33	2.10	2.22	10
	Flare Station Post H2S	1.60	1.82	1.71	13
Unidentified sulfurs	Parnell Inlet	25.5	22.4	24.0	13
	Zeeco Inlet	5.91	5.90	5.91	0.17
	Hero Inlet	24.5	23.0	23.8	6.3
	TF 7B	1.63	1.74	1.69	6.5
	Canyon D	0.24	0.21	0.23	13
	TF 13	0.09	0.08	0.09	12
	Flare Station Pre H2S	10.7	10.2	10.5	4.8
	Flare Station Post H2S	21.3	23.2	22.3	8.5

Eight Silco canister samples, laboratory numbers 23285-(36-43), were analyzed for total sulfur compounds. Agreement between repeat analyses is a measure of precision and is shown above in the column "% RPD". The average % RPD for 71 repeat measurements from eight Silco canister samples is 5.6%.



CHAIN OF CUSTODY RECORD

Client/Project Name: MAQS Chiquita 4th Qtr		Project Location: Chiquita Landfill		ANALYSES REQUESTED			
Project Number: PROJ-061273		Purchase Order Number:		ASTM 1945/3588 Fixed Gases	TO-15 Rule 1150.1	SCAQMD 307-91	
Sampler: (Signature) 		Turnaround Times: Standard 10 day Expedited: 24hr / 48hr / 72hr / 6 day					
Client Sample Identification	Type of Sample Canister ID	AtmAA Lab Number	Sampling Date	Sampling Time			Special Remarks
PAENBIL INLET	236021	2326536	11/24/05	0730	X	X	
ZUEW INLET	246043	37		0730	X	X	
HEBO INLET	236017	38		0910	X	X	
TF TB	246051	35		0845	X	X	
CANYON D	246049	40		0920	X	X	
TF B3	236014	41		0920	X	X	
FLAME STATION PREHTS	236018	42		1000	X	X	
FLAME STATION POST HTS	236028	43		1000	X	X	
Relinquished by: (Signature) 	Date	Time	Received by: (Signature)		Date	Time	
	11/24/05	1124					
Relinquished by: (Signature)	Date	Time	Received by: (Signature)		Date	Time	
Relinquished by: (Signature)	Date	Time	Received for Laboratory by: (Signature)		Date	Time	
					11/24/05	11:24	
Company Info:		Send Report to:		Analytical Laboratory			
Company: Montrose AQS	Company:	Same		AtmAA Inc.			
Street Address: 1631 E St. Andrew Place	Street Address			23917 Craftsman Rd.			
City/State/Zip: Santa Ana, CA	City/State/Zip:			Galabasas, CA 91302			
Telephone No.: 626-617-6313	Project Manager:			TEL: (818) 223-3277			
Email Address: psarjuan@montrose-env.com	Email Address:			EMAIL Address: info@atmaa.com			

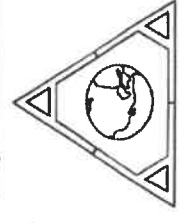

Appendix A.4 Quality Assurance Data

Barometric Pressure Determination

Date: 11/24/25

Time: 7:00

Data By: SJ, AD, JI

Reference: <https://forecast.weather.gov/MapClick.php?lat=33.6873&l>
 Lat: 34.42972°N Lon: 118.66712°W Elev: 1278.0ft.

Reference Barometer ID	DEL VALLE (DLVC1)
Reference Barometer Location	
Reference Barometer Other Info.	
Reference Barometer Indication, corrected to sea level	
Reference Barometer Reference Elevation	1278
Reference Barometer Actual Pressure	28.66
Test Barometer Location/Site	Chiquita Canyon
Location/Site Elevation	997
Location/Site Barometric Pressure	28.94
Sampling Location Height (above/below site elevation)	1
Sampling Location Barometric Pressure	28.94



THERMOCOUPLE CALIBRATION

Thermocouple ID: TC-WB
 Date: 7/2/2025
 Performed By: PR/PC

Calibrated Digital Temperature Readout ID: PTC-90
 T1 Reference Thermometer ID: 2736
 T2 Reference Thermometer ID: 2788
 T3 Reference Thermometer ID: 0425-3218

T/C I.D. TC-WB	Readout I.D.	T/C - Readout °F				Reference Thermometer °F				Difference		
		Reading 1	Reading 2	Reading 3	Average	Reading 1	Reading 2	Reading 3	Average	°F	%, (°R)	
T3 (~ 370 F)	PTC-90	361	361	361	361	370	370	370	370	9.0	1.1%	Pass
T2 (~ 212 F)	PTC-90	206	207	207	207	212	212	212	212	5.3	0.8%	Pass
T1 (~ 32 F)	PTC-90	29	29	29	29	32	32	32	32	3.0	0.6%	Pass

1) Difference % (°R) = Difference (°F) / (Average Tref + 460)

2) Pass if all Differences are less than 1.5% (°R)



THERMOCOUPLE CALIBRATION

Thermocouple ID: TC-DB
 Date: 7/2/2025
 Performed By: PR/PC

Calibrated Digital Temperature Readout ID: PTC-90
 T1 Reference Thermometer ID: 2736
 T2 Reference Thermometer ID: 2788
 T3 Reference Thermometer ID: 0425-3218

T/C I.D.	Readout I.D.	T/C - Readout °F				Reference Thermometer °F				Difference			
		Reading 1	Reading 2	Reading 3	Average	Reading 1	Reading 2	Reading 3	Average	°F	%. (°R)		
TC-DB													
T3 (~ 370 F)	PTC-90	365	365	365	365	370	370	370	370	5.0	0.6%	Pass	
T2 (~ 212 F)	PTC-90	215	215	215	215	212	212	212	212	3.0	0.4%	Pass	
T1 (~ 32 F)	PTC-90	33	33	33	33	32	32	32	32	1.0	0.2%	Pass	

1) Difference % (°R) = Difference (°F) / (Average Tref + 460)

2) Pass if all Differences are less than 1.5% (°R)



THERMOCOUPLE CALIBRATION

Thermocouple ID: 180
 Date: 7/2/2025
 Performed By: PR/PC

Calibrated Digital Temperature Readout ID: PTC-90
 T1 Reference Thermometer ID: 2736
 T2 Reference Thermometer ID: 2788
 T3 Reference Thermometer ID: 0425-3218

T/C I.D. 180	Readout I.D.	T/C - Readout °F				Reference Thermometer °F				Difference		
		Reading 1	Reading 2	Reading 3	Average	Reading 1	Reading 2	Reading 3	Average	°F	%, (°R)	
T3 (~ 370 F)	PTC-90	368	368	368	368	370	370	370	370	2.0	0.2%	Pass
T2 (~ 212 F)	PTC-90	213	213	213	213	212	212	212	212	1.0	0.1%	Pass
T1 (~ 32 F)	PTC-90	35	34	34	34	32	32	32	32	2.3	0.5%	Pass

1) Difference % (°R) = Difference (°F) / (Average Tref + 460)

2) Pass if all Differences are less than 1.5% (°R)



DIGITAL TEMPERATURE READOUT CALIBRATION

Digital Temperature Readout ID: PTC-43
 Readout Description: Handheld
 Date: 7/2/2025
 Performed By: PR/PC

Calibrated Thermocouple ID: TC-Cal
 T1 Reference Thermometer ID: 2736
 T2 Reference Thermometer ID: 2788
 T3 Reference Thermometer ID: 0425-3218

T/C I.D.	Readout I.D.	T/C - Readout °F				Reference Thermometer °F				Difference			
		Reading 1	Reading 2	Reading 3	Average	Reading 1	Reading 2	Reading 3	Average	°F	%, (°R)		
TC-Cal													
T3 (~ 370 F)	PTC-43	368	368	367	368	370	370	370	370	2.3	0.3%	Pass	
T2 (~212 F)	PTC-43	210	211	210	210	212	212	212	212	1.7	0.2%	Pass	
T1 (~ 32 F)	PTC-43	33	33	33	33	32	32	32	32	1.0	0.2%	Pass	

- 1) Difference % (°R) = Difference (°F) / (Average Tref + 460)
- 2) Pass if all Differences are less than 1.5% (°R)

Thermocouple Source Readings

T/C Source S/N	T/C - Readout °F				T/C Source °F				Difference			
	Reading 1	Reading 2	Reading 3	Average	Reading 1	Reading 2	Reading 3	Average	°F	%, (°R)		
T4 (~650 F)	129462	651	651	651	651	650	650	650	650	1.0	0.1%	Pass
T3 (~370 F)	129462	371	371	371	371	370	370	370	370	1.0	0.1%	Pass
T2 (~212 F)	129462	213	213	214	213	212	212	212	212	1.3	0.2%	Pass
T1 (~32 F)	129462	33	34	33	33	32	32	32	32	1.3	0.3%	Pass

- 1) Difference % (°R) = Difference (°F) / (Average Tref + 460)
- 2) Pass if all Differences are less than 1.5% (°R)

S Type Pitot Tube Dimensional Calibration Record

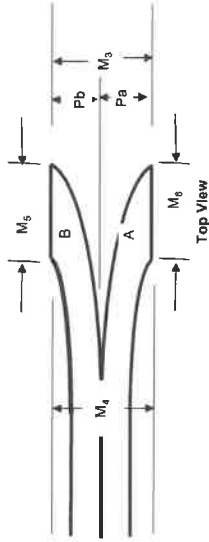
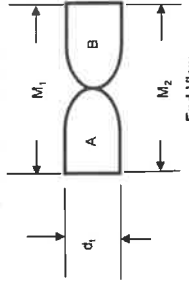
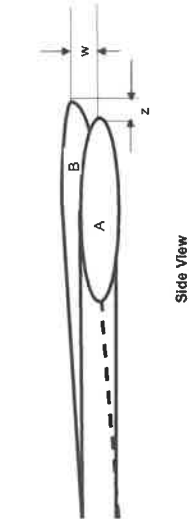

Pitot ID	Acceptability Criteria		Yes	"3/16" < Dt < 3/8"	n/a	n/a	n/a	n/a	n/a	n/a	n/a	10 degrees Average Face Opening Plane Angle, offset from perpendicular to transverse axis	5 degrees Average Face Opening Plane Frontal Angle from parallel to Longitudinal Axis	1.05 Dt < P < 1.5 Dt	Status
	Date	Calibrated By													
180	7/2/25	JJRC	Y	Y	Y	Y	Y	0.476	0.478	0.477	0.473	0.210	0.213	1.3	Pass

Notes: Reference "A Type-S Pitot Tube Calibration Study", Robert F. Vollaro, October 15, 1975
If tube is not visibly deformed it is assumed that Pa = Pb = .5 x avg. of M1 & M2, and that average face opening plane angles represent individual angles to tube axis

DIFFERENTIAL PRESSURE CALIBRATION

Semi-annual

Display ID: ADM 9
 Description: Air Data Multimeter (ADM 850)
 Serial Number: M14140
 Calibration Date: 7/2/2025

Reference Device ID: Microtector
 Reference Serial Number: S270
 Calibrated By: K. Thomas

Calibration Range Scale: 0 - 0.050 inches H ₂ O	Run 1		Individual Run Results % Difference	Pass/ Fail
	Measured Value (inches W.C.)	Reference Value (inches W.C.)		
Target 20%	0.010	0.010	0.00%	Pass
Target 40%	0.020	0.020	0.00%	Pass
Target 60%	0.031	0.030	3.33%	Pass
Target 80%	0.040	0.040	0.00%	Pass
Target 100%	0.050	0.050	0.00%	Pass

Calibration Range Scale: 0 - 0.050 inches H ₂ O	Run 2		Individual Run Results % Difference	Pass/ Fail
	Measured Value (inches W.C.)	Reference Value (inches W.C.)		
Target 20%	0.010	0.010	0.00%	Pass
Target 40%	0.020	0.020	0.00%	Pass
Target 60%	0.030	0.030	0.00%	Pass
Target 80%	0.041	0.040	2.50%	Pass
Target 100%	0.052	0.050	4.00%	Pass

Calibration Range Scale: 0 - 0.050 inches H ₂ O	Run 3		Individual Run Results % Difference	Pass/ Fail
	Measured Value (inches W.C.)	Reference Value (inches W.C.)		
Target 20%	0.010	0.010	0.00%	Pass
Target 40%	0.020	0.020	0.00%	Pass
Target 60%	0.031	0.030	3.33%	Pass
Target 80%	0.040	0.040	0.00%	Pass
Target 100%	0.050	0.050	0.00%	Pass

Average results for three runs

% Difference	0.88%	Pass/Fail	Pass
--------------	-------	-----------	------

Criteria: Each individual measured value within + or - 5.0% of reference value.
 Percent difference of three run average within 5.0 %.



DIFFERENTIAL PRESSURE CALIBRATION

Semi-annual

Display ID: ADM 9
 Description: Air Data Multimeter (ADM 850)
 Serial Number: M14140
 Calibration Date: 7/2/2025

Reference Device ID: Microtector
 Reference Serial Number: SZ70
 Calibrated By: K. Thomas

Calibration Range		Run 1		Individual Run Results		
Scale: 0 - 0.100 inches H ₂ O		Measured Value (inches W.C.)	Reference Value (inches W.C.)	Absolute Value	% Difference	Pass/ Fail
Target 20%	0.020	0.020	0.020	0.0000	0.00%	Pass
Target 40%	0.040	0.040	0.040	0.0000	0.00%	Pass
Target 60%	0.060	0.062	0.060	0.0020	3.33%	Pass
Target 80%	0.080	0.080	0.080	0.0000	0.00%	Pass
Target 100%	0.100	0.102	0.100	0.0020	2.00%	Pass

Calibration Range		Run 2		Individual Run Results		
Scale: 0 - 0.100 inches H ₂ O		Measured Value (inches W.C.)	Reference Value (inches W.C.)	Absolute Value	% Difference	Pass/ Fail
Target 20%	0.020	0.020	0.020	0.0000	0.00%	Pass
Target 40%	0.040	0.040	0.040	0.0000	0.00%	Pass
Target 60%	0.060	0.061	0.060	0.0010	1.67%	Pass
Target 80%	0.080	0.079	0.080	0.0010	1.25%	Pass
Target 100%	0.100	0.100	0.100	0.0000	0.00%	Pass

Calibration Range		Run 3		Individual Run Results		
Scale: 0 - 0.100 inches H ₂ O		Measured Value (inches W.C.)	Reference Value (inches W.C.)	Absolute Value	% Difference	Pass/ Fail
Target 20%	0.020	0.020	0.020	0.0000	0.00%	Pass
Target 40%	0.040	0.041	0.040	0.0010	2.50%	Pass
Target 60%	0.060	0.060	0.060	0.0000	0.00%	Pass
Target 80%	0.080	0.080	0.080	0.0000	0.00%	Pass
Target 100%	0.100	0.100	0.100	0.0000	0.00%	Pass

Average results for three runs

% Difference	Pass/Fail
0.72%	Pass

Criteria: Each individual measured value within + or - 5.0% of reference value.
 Percent difference of three run average within 5.0 %.



DIFFERENTIAL PRESSURE CALIBRATION

Semi-annual

Display ID: ADM 9
 Description: Air Data Multimeter (ADM 850)
 Serial Number: M14140
 Calibration Date: 7/2/2025

Reference Device ID: Microtector
 Reference Serial Number: S270
 Calibrated By: K. Thomas

Calibration Range		Run 1		Individual Run Results		
Scale: 0 - 1.000 inches H ₂ O		Measured Value (inches W.C.)	Reference Value (inches W.C.)	Absolute Value	% Difference	Pass/ Fail
Target 20%	0.200	0.200	0.200	0.0000	0.00%	Pass
Target 40%	0.400	0.400	0.400	0.0000	0.00%	Pass
Target 60%	0.600	0.602	0.600	0.0020	0.33%	Pass
Target 80%	0.800	0.801	0.800	0.0010	0.13%	Pass
Target 100%	1.000	1.010	1.000	0.0100	1.00%	Pass

Calibration Range		Run 2		Individual Run Results		
Scale: 0 - 1.000 inches H ₂ O		Measured Value (inches W.C.)	Reference Value (inches W.C.)	Absolute Value	% Difference	Pass/ Fail
Target 20%	0.200	0.201	0.200	0.0010	0.50%	Pass
Target 40%	0.400	0.401	0.400	0.0010	0.25%	Pass
Target 60%	0.600	0.602	0.600	0.0020	0.33%	Pass
Target 80%	0.800	0.801	0.800	0.0010	0.13%	Pass
Target 100%	1.000	1.000	1.000	0.0000	0.00%	Pass

Calibration Range		Run 3		Individual Run Results		
Scale: 0 - 1.000 inches H ₂ O		Measured Value (inches W.C.)	Reference Value (inches W.C.)	Absolute Value	% Difference	Pass/ Fail
Target 20%	0.200	0.200	0.200	0.0000	0.00%	Pass
Target 40%	0.400	0.402	0.400	0.0020	0.50%	Pass
Target 60%	0.600	0.602	0.600	0.0020	0.33%	Pass
Target 80%	0.800	0.803	0.800	0.0030	0.38%	Pass
Target 100%	1.000	1.000	1.000	0.0000	0.00%	Pass

Average results for three runs

% Difference	Pass/Fail
0.26%	Pass

Criteria: Each individual measured value within + or - 5.0% of reference value.
 Percent difference of three run average within 5.0 %.



DIFFERENTIAL PRESSURE CALIBRATION

Semi-annual

Display ID: ADM 9
 Description: Air Data Multimeter (ADM 850)
 Serial Number: M14140
 Calibration Date: 7/2/2025

Reference Device ID: Dwyer 0 - 10" Manometer
 Reference Serial Number: CC-2
 Calibrated By: K. Thomas

Calibration Range		Run 1		Individual Run Results		
Scale:	inches H ₂ O	Measured Value (inches W.C.)	Reference Value (inches W.C.)	Absolute Value	% Difference	Pass/ Fail
Target 20%	2.000	2.015	2.000	0.0150	0.75%	Pass
Target 40%	4.000	4.020	4.000	0.0200	0.50%	Pass
Target 60%	6.000	6.005	6.000	0.0050	0.08%	Pass
Target 80%	8.000	8.035	8.000	0.0350	0.44%	Pass
Target 100%	10.000	10.010	10.000	0.0100	0.10%	Pass

Calibration Range		Run 2		Individual Run Results		
Scale:	inches H ₂ O	Measured Value (inches W.C.)	Reference Value (inches W.C.)	Absolute Value	% Difference	Pass/ Fail
Target 20%	2.000	2.005	2.000	0.0050	0.25%	Pass
Target 40%	4.000	4.010	4.000	0.0100	0.25%	Pass
Target 60%	6.000	6.015	6.000	0.0150	0.25%	Pass
Target 80%	8.000	8.000	8.000	0.0000	0.00%	Pass
Target 100%	10.000	10.000	10.000	0.0000	0.00%	Pass

Calibration Range		Run 3		Individual Run Results		
Scale:	inches H ₂ O	Measured Value (inches W.C.)	Reference Value (inches W.C.)	Absolute Value	% Difference	Pass/ Fail
Target 20%	2.000	2.005	2.000	0.0050	0.25%	Pass
Target 40%	4.000	4.020	4.000	0.0200	0.50%	Pass
Target 60%	6.000	6.050	6.000	0.0500	0.83%	Pass
Target 80%	8.000	8.010	8.000	0.0100	0.12%	Pass
Target 100%	10.000	10.000	10.000	0.0000	0.00%	Pass

Average results for three runs

% Difference	Pass/Fail
0.29%	Pass

Criteria: Each individual measured value within + or - 5.0% of reference value.
 Percent difference of three run average within 5.0 %.



APPENDIX B GENERAL EMISSIONS CALCULATIONS

GENERAL EMISSIONS CALCULATIONS

I. Stack Gas Velocity

A. Stack gas molecular weight, lb/lb-mole

$$MW_{dry} = 0.44 * \% CO_2 + 0.32 * \% O_2 + 0.28 * \% N_2$$

$$MW_{wet} = MW_{dry} * (1 - B_{wo}) + 18 * B_{wo}$$

B. Absolute stack pressure, iwg

$$P_s = P_{bar} + \frac{P_{sg}}{13.6}$$

C. Stack gas velocity, ft/sec

$$V_s = 2.9 * C_p * \sqrt{\Delta P} * \sqrt{T_s} * \sqrt{\frac{29.92 * 28.95}{P_s * MW_{wet}}}$$

II. Moisture

A. Sample gas volume, dscf

$$V_{mstd} = 0.03342 * V_m * \left(P_{bar} + \frac{\Delta H}{13.6} \right) * \frac{T_{ref}}{T_m} * Y_d$$

B. Water vapor volume, scf

$$V_{wstd} = 0.0472 * V_{ic} * \frac{T_{ref}}{528^\circ R}$$

C. Moisture content, dimensionless

$$B_{wo} = \frac{V_{wstd}}{(V_{mstd} + V_{wstd})}$$

III. Stack Gas Volumetric Flow Rate

A. Actual stack gas volumetric flow rate, wacfm

$$Q = V_s * A_s * 60$$

B. Standard stack gas flow rate, dscfm

$$Q_{sd} = Q * (1 - B_{wo}) * \frac{T_{ref}}{T_s} * \frac{P_s}{29.92}$$

Nomenclature:

A_s	=	stack area, ft ²
B_{wo}	=	flue gas moisture content, dimensionless
$C_{12\%CO_2}$	=	particulate grain loading, gr/dscf corrected to 12% CO ₂
C	=	particulate grain loading, gr/dscf
C_p	=	pitot calibration factor, dimensionless
D_n	=	nozzle diameter, inches
F	=	fuel F-Factor, dscf/MMBtu @ 0% O ₂
H	=	orifice differential pressure, iwg
I	=	% isokinetics
M_n	=	mass of collected particulate, mg
M_i	=	mass emission rate of specie i, lb/hr
MW	=	molecular weight of flue gas, lb/lb-mole
M_{wi}	=	molecular weight of specie i:
		SO ₂ : 64
		NO _x : 46
		CO: 28
		HC: 16
t	=	sample time, minutes
ΔP	=	average velocity head, iwg = $(\sqrt{\Delta P})^2$
P_{bar}	=	barometric pressure, inches Hg
P_s	=	stack absolute pressure, inches Hg
P_{sg}	=	stack static pressure, iwg
Q	=	wet stack flow rate at actual conditions, wacfm
Q_{sd}	=	dry standard stack flow rate, dscfm
SV	=	specific molar volume of an ideal gas at standard conditions, ft ³ /lb-mole
T_m	=	meter temperature, °R
T_{ref}	=	reference temperature, °R
T_s	=	stack temperature, °R
V_s	=	stack gas velocity, ft/sec
V_{lc}	=	volume of liquid collected in impingers, ml
V_m	=	uncorrected dry meter volume, dcf
V_{mstd}	=	dry meter volume at standard conditions, dscf
V_{wstd}	=	volume of water vapor at standard conditions, scf
Y_d	=	meter calibration coefficient

APPENDIX C QUALITY ASSURANCE

Appendix C.1

Quality Assurance Program Summary

QUALITY ASSURANCE PROGRAM SUMMARY

As part of Montrose Air Quality Services, LLC (Montrose) ASTM D7036-04 certification, Montrose is committed to providing emission related data which is complete, precise, accurate, representative, and comparable. Montrose quality assurance program and procedures are designed to ensure that the data meet or exceed the requirements of each test method for each of these items. The quality assurance program consists of the following items:

- Assignment of an Internal QA Officer
- Development and use of an internal QA Manual
- Personnel training
- Equipment maintenance and calibration
- Knowledge of current test methods
- Chain-of-custody
- QA reviews of test programs

Assignment of an Internal QA Officer: Montrose has assigned an internal QA Officer who is responsible for administering all aspects of the QA program.

Internal Quality Assurance Manual: Montrose has prepared a QA Manual according to the requirements of ASTM D7036-04 and guidelines issued by EPA. The manual documents and formalizes all of Montrose's QA efforts. The manual is revised upon periodic review and as Montrose adds capabilities. The QA manual provides details on the items provided in this summary.

Personnel Testing and Training: Personnel testing and training is essential to the production of high quality test results. Montrose training programs include:

- A requirement for all technical personnel to read and understand the test methods performed
- A requirement for all technical personnel to read and understand the Montrose QA manual
- In-house testing and training
- Quality Assurance meetings
- Third party testing where available
- Maintenance of training records.

Equipment Maintenance and Calibration: All laboratory and field equipment used as a part of Montrose's emission measurement programs is maintained according to manufacturer's recommendations. A summary of the major equipment maintenance schedules is summarized in Table 1. In addition to routine maintenance, calibrations are performed on all sampling equipment according to the procedures outlined in the applicable test method. The calibration intervals and techniques for major equipment components is summarized in Table 2. The calibration technique may vary to meet regulatory agency requirements.

Knowledge of Current Test Methods: Montrose maintains current copies of EPA, ARB, and SCAQMD Source Test Manuals and Rules and Regulations.

Chain-of-Custody: Montrose maintains chain-of-custody documentation on all data sheets and samples. Samples are stored in a locked area accessible only to Montrose source test personnel. Data sheets are kept in the custody of the originator, program manager, or in locked storage until return to Montrose office. Electronic field data is duplicated for backup on secure storage media. The original data sheets are used for report preparation and any additions are initialed and dated.

QA Reviews: Periodic field, laboratory, and report reviews are performed by the in-house QA coordinator. Periodically, test plans are reviewed to ensure proper test methods are selected and reports are reviewed to ensure that the methods were followed and any deviations from the methods are justified and documented.

ASTM D7036-04 Required Information

Uncertainty Statement

Montrose is qualified to conduct this test program and has established a quality management system that led to accreditation with ASTM Standard D7036-04 (Standard Practice for Competence of Air Emission Testing Bodies). Montrose participates in annual functional assessments for conformance with D7036-04 which are conducted by the American Association for Laboratory Accreditation (A2LA). All testing performed by Montrose is supervised on site by at least one Qualified Individual (QI) as defined in D7036-04 Section 8.3.2. Data quality objectives for estimating measurement uncertainty within the documented limits in the test methods are met by using approved test protocols for each project as defined in D7036-04 Sections 7.2.1 and 12.10. Additional quality assurance information is presented in the report appendices.

Performance Data

Performance data are available for review.

Qualified Personnel

A qualified individual (QI), defined by performance on a third party or internal test on the test methods, is present on each test event.

Plant Entry and Safety Requirements

Plant Entry

All test personnel are required to check in with the guard at the entrance gate or other designated area. Specific details are provided by the facility and project manager.

Safety Requirements

All personnel shall have the following personal protective equipment (PPE) and wear them where designated:

- Hard Hat
- Safety Glasses
- Steel Toe Boots
- Hearing Protection
- Gloves
- High Temperature Gloves (if required)
- Flame Resistant Clothing (if required)

The following safety measures are followed:

- Good housekeeping
- SDS for all on-site hazardous materials
- Confine selves to necessary areas (stack platform, mobile laboratory, CEMS data acquisition system, control room, administrative areas)
- Knowledge of evacuation procedures

Each facility will provide plant specific safety training.

**TABLE 1
 EQUIPMENT MAINTENANCE SCHEDULE**

Equipment	Acceptance Limits	Frequency of Service	Methods of Service
Pumps	<ol style="list-style-type: none"> 1. Absence of leaks 2. Ability to draw manufacturers required vacuum and flow 	As recommended by manufacturer	<ol style="list-style-type: none"> 1. Visual inspection 2. Clean 3. Replace parts 4. Leak check
Flow Meters	<ol style="list-style-type: none"> 1. Free mechanical movement 	As recommended by manufacturer	<ol style="list-style-type: none"> 1. Visual inspection 2. Clean 3. Calibrate
Sampling Instruments	<ol style="list-style-type: none"> 1. Absence of malfunction 2. Proper response to zero span gas 	As recommended by manufacturer	As recommended by manufacturer
Integrated Sampling Tanks	<ol style="list-style-type: none"> 1. Absence of leaks 	Depends on nature of use	<ol style="list-style-type: none"> 1. Steam clean 2. Leak check
Mobile Van Sampling System	<ol style="list-style-type: none"> 1. Absence of leaks 	Depends on nature of use	<ol style="list-style-type: none"> 1. Change filters 2. Change gas dryer 3. Leak check 4. Check for system contamination
Sampling Lines	<ol style="list-style-type: none"> 1. Sample degradation less than 2% 	After each test series	<ol style="list-style-type: none"> 1. Blow dry, inert gas through line until dry

TABLE 2
MAJOR SAMPLING EQUIPMENT CALIBRATION REQUIREMENTS

Sampling Equipment	Calibration Frequency	Calibration Procedure	Acceptable Calibration Criteria
Continuous Analyzers	Before and After Each Test Day	3-point calibration error test	< 2% of analyzer range
Continuous Analyzers	Before and After Each Test Run	2-point sample system bias check	< 5% of analyzer range
Continuous Analyzers	After Each Test Run	2-point analyzer drift determination	< 3% of analyzer range
CEMS System	Beginning of Each Day	leak check	< 1 in. Hg decrease in 5 min. at > 20 in. Hg
Continuous Analyzers	Semi-Annually	3-point linearity	< 1% of analyzer range
NO _x Analyzer	Daily	NO ₂ -> NO converter efficiency	> 90%
Differential Pressure Gauges (except for manometers)	Semi-Annually	Correction factor based on 5-point comparison to standard	± 5%
Differential Pressure Gauges (except for manometers)	Bi-Monthly	3-point comparison to standard, no correction factor	± 5%
Barometer	Semi-Annually	Adjusted to mercury-in-glass or National Weather Service Station	± 0.1 inches Hg
Dry Gas Meter	Semi-Annually	Calibration check at 4 flow rates using a NIST traceable standard	± 2%
Dry Gas Meter	Bi-Monthly	Calibration check at 2 flow rates using a NIST traceable standard	± 2% of semi-annual factor
Dry Gas Meter Orifice	Annually	4-point calibration for ΔH@	--
Temperature Sensors	Semi-Annually	3-point calibration vs. NIST traceable standard	± 1.5%

Note: Calibration requirements that meet applicable regulatory agency requirements are used.

Appendix C.2

SCAQMD and STAC Certifications

SCS Engineers – Chiquita Canyon Landfill
2025 4th Quarter Leachate and Condensate Vapor Sampling



South Coast
Air Quality Management District

21865 Copley Drive, Diamond Bar, CA 91765-4178
(909) 396-2000 • www.aqmd.gov

September 18, 2025

Mr. John Peterson
Montrose Air Quality Services, LLC
1631 E. Saint Andrew Place
Santa Ana, CA 92705

Subject: LAP Approval Notice
Reference # 96LA1220

Dear Mr. Peterson:

We have completed our review of Montrose Air Quality Services' renewal application under the South Coast AQMD Laboratory Approval Program (LAP). We are pleased to inform you that your firm is approved for the period beginning September 30, 2025, and ending September 30, 2026, for the following methods, subject to the requirements in the LAP Conditions For Approval Agreement and conditions listed in the attachment to this letter:

South Coast AQMD Methods 1-4
South Coast AQMD Methods 10.1 and 100.1
South Coast AQMD Methods 5.1, 5.2, 5.3, 6.1 (Sampling and Analysis)
South Coast AQMD Methods 25.1 and 25.3 (Sampling)
Rule 1121/ 1146.2 Protocol
Rule 1420/1420.1/1420.2 – (Lead) Source and Ambient Sampling
USEPA CTM-030 and ASTM D6522-00

Your LAP approval to perform nitrogen oxide emissions compliance testing for Rule 1121/ 1146.2 Protocols includes satellite facilities located at:

McKenna Boiler
1510 North Spring Street
Los Angeles, CA 90012

Noritz America Corp.
11160 Grace Avenue
Fountain Valley, CA 92708

Ajax Boiler, Inc.
2701 S. Harbor Blvd.
Santa Ana, CA 92704

VA Laundry Bldg., Greater LA Healthcare Sys.
508 Constitution Avenue
Los Angeles, CA 90049

So Cal Gas – Engr Analysis Ctr, Bldg H
8101 Rosemead Blvd
Pico Rivera, CA 90660

Thank you for participating in the LAP. Your cooperation helps us to achieve the goal of the LAP: to maintain high standards of quality in the sampling and analysis of source emissions. You may direct any questions or information to me by telephone at (909) 396-2476, or via e-mail at ceckerle@aqmd.gov.

Sincerely,

Colin Eckerle
Program Supervisor
Source Test Engineering

CE/ce
Attachment
250918 LapRenewal.doc



American Association for Laboratory Accreditation

Accredited Air Emission Testing Body

A2LA has accredited

MONTROSE AIR QUALITY SERVICES

In recognition of the successful completion of the joint A2LA and Stack Testing Accreditation Council (STAC) evaluation process, this laboratory is accredited to perform testing activities in compliance with ASTM D7036:2004 - Standard Practice for Competence of Air Emission Testing Bodies.



Presented this 27th day of February, 2024.

Vice President, Accreditation Services
For the Accreditation Council
Certificate Number: 3925.01
Valid to February 28, 2026

This accreditation program is not included under the A2LA ILAC Mutual Recognition Arrangement.

Appendix C.3

Individual QI Certifications

CERTIFICATE OF COMPLETION

Pedro SanJuan

This document certifies that this individual has passed a comprehensive examination and is now a Qualified Individual (QI) as defined in Section 8.3 of ASTM D7036-04 for the following method(s):

SCAQMD Methods 1.1, 1.2, 2.1, 2.2, 2.3, 3.1, & 4.1

Certificate Number: 002-2022-50

Tate Strickler
Tate Strickler, VP – Quality Systems

DATE OF ISSUE: 02/28/2022

DATE OF EXPIRATION: 02/27/2027

MONTROSE
ENVIRONMENTAL

CERTIFICATE OF COMPLETION

Pedro SanJuan

This document certifies that this individual has passed a comprehensive examination and is now a Qualified Individual (QI) as defined in Section 8.3 of ASTM D7036-04 for the following method(s):

SCAQMD Methods 25.1, 25.3 & 307-91

Certificate Number: 002-2022-52

Tate Strickler
Tate Strickler, VP – Quality Systems

DATE OF ISSUE: 02/28/2022

DATE OF EXPIRATION: 02/27/2027

 **MONTROSE**
ENVIRONMENTAL

CERTIFICATE OF COMPLETION

Pedro Sanjuan

This document certifies that this individual has passed a comprehensive examination and is now a Qualified Individual (QI) as defined in Section 8.3 of ASTM D7036-04 for the following method(s):

EPA Methods 3C, TO-8, TO-12 and TO-15

Certificate Number: 002-2023-48

Tate Strickler
Tate Strickler, VP – Quality Systems

DATE OF ISSUE: 11/01/2023

DATE OF EXPIRATION: 10/31/2028

MONTROSE
ENVIRONMENTAL

Appendix C.4

Statement of No Conflict of Interest

**STATEMENT OF NO CONFLICT OF INTEREST AS AN INDEPENDENT TESTING
LABORATORY**

(To be completed by authorized source testing firm representative and included in source test report)

The following facility and equipment were tested by my source testing firm and are the subjects of this statement:

Facility ID:	119219
Date(s) Tested:	November 24, 2025
Facility Name:	Chiquita Canyon Landfill
Equipment Address:	29201 Henry Mayo Drive Castaic, California 91384
Equipment Tested:	Leachate and Condensate Sampling System

I state, as its legally authorized representative, that the source testing firm of:

Source Test Firm: Montrose Air Quality Services, LLC
Business Address: 1631 E. St. Andrew Pl.
Santa Ana, California 92705

is an "Independent Testing Laboratory" as defined in **District Rule 304(k)**:

For the purposes of this Rule, when an independent testing laboratory is used for the purposes of establishing compliance with District rules or to obtain a District permit to operate, it must meet all of the following criteria:

- (1) The testing laboratory shall have no financial interest in the company or facility being tested, or in the parent company, or any subsidiary thereof -*
- (2) The company or facility being tested, or parent company or any subsidiary thereof, shall have no financial interest in the testing laboratory;*
- (3) Any company or facility responsible for the emission of significant quantities of pollutants to the atmosphere, or parent company or any subsidiary thereof shall have no financial interest in the testing laboratory; and*
- (4) The testing laboratory shall not be in partnership with, own or be owned by, in part or in full, the contractor who has provided or installed equipment (basic or control), or monitoring systems, or is providing maintenance for installed equipment or monitoring systems, for the company being tested.*

Furthermore, I state that any contracts or agreements entered into by my source testing firm and the facility referenced above, or its designated contractor(s), either verbal or written, are not contingent upon the outcome of the source testing, or the source testing information provided to the SCAQMD.

Signature: _____

Date: 12/24/2025

Pete SanJuan

Client Project Manager

(714) 279-6777

12/24/2025

(Name)

(Title)

(Phone)

(Date)

APPENDIX D FACILITY PERMIT



**FACILITY PERMIT TO OPERATE
CHIQUITA CANYON LLC**

PERMIT TO CONSTRUCT/OPERATE

**Permit No. G66132
A/N 613131**

Equipment Description:

Modification of an existing Landfill Gas Condensate and Leachate Collection/Storage System consisting of:

1. Condensate storage tank, 5,000-gallon capacity, at Canyon B.
2. Condensate storage tank, 10,000-gallon capacity, at Primary Canyon.
3. Condensate storage tanks, three (3), each 6,650-gallon capacity, at flare station.
4. Leachate collection tanks, up to (4), each 10,000-gallon capacity, and one 1,600-gallon capacity, with associated sump pump and transfer pumps.

By removal of:

1. One 1,600-gallon capacity leachate collection tank [under Item 4].

By addition of:

1. One 10,000-gallon capacity leachate collection tank [to Item 4].

Conditions:

1. Operation of this equipment shall be conducted in accordance with all data and specifications submitted with the application under which this permit is issued unless otherwise noted below.
[Rule 204]
2. This equipment shall be properly maintained and kept in good operating condition at all times.
[Rule 204]
3. This equipment shall be operated and maintained by personnel properly trained in its operation.
[Rule 204]
4. This equipment shall be vented to air pollution control equipment which is in full operation and has been issued a valid Permit to Construct or Operate by the South Coast AQMD.
[Rule 1303(a)(1)-BACT]
5. This equipment shall be used only for the storage of landfill gas condensate and leachate collection.
[Rule 204]
6. All connectors, valves and openings shall be properly sealed or closed at all times to prevent landfill gas condensate vapors from entering into the atmosphere unless disposal of the condensate/leachate is taking place or during maintenance or repairs.
[Rule 204]



**FACILITY PERMIT TO OPERATE
CHIQUITA CANYON LLC**

7. Any breakdown or malfunction of the landfill gas condensate/leachate storage system shall be reported to South Coast AQMD within one hour after occurrence, or within one hour of the time personnel knew or reasonably should have known of its occurrence, per Rule 430 requirements, and remedial measures shall be undertaken to correct the problem and prevent further emissions into the atmosphere in a timely manner.
[Rule 430]
8. The operator shall keep and maintain adequate records for this equipment to verify compliance with the conditions of this permit. These records shall be prepared in a format which is acceptable to the South Coast AQMD. Records shall be kept for at least five years and made available to South Coast AQMD personnel upon request.
[Rule 204]
9. This permit shall expire if construction of this equipment is not complete within one year from the date of issuance of this permit unless an extension is granted by the Executive Officer.
[Rule 204]

THIS IS THE LAST PAGE OF THIS DOCUMENT

If you have any questions, please contact one of the following individuals by email or phone.

Name: Mr. Pete SanJuan
Title: Client Project Manager
Region: West
Email: PSanjuan@montrose-env.com
Phone: (714) 279-6777

Name: Mr. Matt McCune
Title: Principal
Region: West
Email: MMccune@montrose-env.com
Phone: (714) 279-6777