



**CLEAN FUELS PROGRAM ADVISORY GROUP AGENDA  
 SEPTEMBER 17, 2025, 9:00 AM – 4:30 PM**  
 National Academies Beckman Center  
 Huntington Room  
 100 Academy Way  
 Irvine, CA 92617

**TELECONFERENCE LOCATIONS**

Union of Concerned Scientists 200 East Randolph Street Chicago, IL 60601	Port of Long Beach 415 W. Ocean Blvd. Long Beach, CA 90802	University of Nevada, Reno Ross Hall, Rm 201 1664 N. Virginia Street Reno, NV 89557
--	--	--

**A meeting of the South Coast Air Quality Management District Clean Fuels Program Advisory Committee will be held at 9:00 a.m. on Wednesday, September 17, 2025, through a hybrid format of in-person attendance in the National Academies Beckman Center, Huntington Room, 100 Academy Way, Irvine, California, and remote attendance via videoconferencing and by telephone. Please follow the instructions below to join the meeting remotely. Please refer to South Coast AQMD’s website for information regarding the format of the meeting, updates if the meeting is changed to a full remote via webcast format, and details on how to participate:**

INSTRUCTIONS FOR ELECTRONIC PARTICIPATION  
 Join Zoom Webinar Meeting - from PC or Laptop  
<https://scaqmd.zoom.us/j/91964955642>  
 Zoom Webinar ID: 919 6495 5642 (applies to all)  
 Teleconference Dial In +1 669 900 6833  
 One tap mobile +16699006833, 91964955642#

Audience will be allowed to provide public comment through telephone or Zoom connection.

**INSTRUCTIONS FOR ELECTRONIC PARTICIPATION AT BOTTOM OF AGENDA**

**AGENDA**

*Members of the public may address this body concerning any agenda item before or during consideration of that item (Gov't. Code Section 54954.3(a)). If you wish to speak, raise your hand on Zoom or press Star 9 if participating by telephone. All agendas for regular meetings are posted at South Coast AQMD Headquarters, 21865 Copley Drive, Diamond Bar, California, at least 72 hours in advance of the regular meeting. Speakers may be limited to two (2) minutes each.*

**Breakfast (Huntington Room Foyer Area)  
 8:00 AM – 9:00 AM**

**Welcome & Overview  
 9:00 AM – 10:15 AM**

- |                                       |  |
|---------------------------------------|--|
| (a) Welcome and Opening Remarks       | Wayne Nastri, Executive Officer, South Coast Air Quality Management District |
| (b) Goals for the Day                 | Vasileios Papapostolou, Sc.D.,<br>Technology Demonstration Manager*          |
| (c) Updates on Grants and Incentives  | Mei Wang, Assistant Deputy Executive Officer*                                |
| (d) Feedback and Discussion           | Advisors and Experts   |
| (e) Public Comment (2 minutes/person) |  |

**Zero Emission Technology Progress I**  
**Moderator - Maryam Hajbabaei, Ph.D., Program Supervisor\***

**1. 10:15 AM – 12:00 PM**

- |     |   |   |
|-----|---|---|
| (a) | The Social Value of Electrolytic Hydrogen   | Robert Flores, Ph.D., Senior Scientist, Advanced Power and Energy Program, University of California, Irvine (UCI) |
| (b) | The Impact of Vehicle-To-Home Technology (V2H) on Air Quality   | Kate Forrest, Ph.D. & Michael Mac Kinnon, Ph.D., Senior Scientists, Advanced Power and Energy Program, UCI        |
| (c) | Estimating Community Air Quality Benefits from Electrification of Heavy-Duty Trucks in Inland Southern California | Matthew Barth, Ph.D., Professor of Electrical and Computer Engineering, University of California, Riverside (UCR) |
| (d) | A Summary Status of Heavy-Duty Vehicle Emissions  | Kent Johnson, Ph.D., Assoc. Research Engineer, UCR  |
| (e) | Feedback and Discussion   | Advisors and Experts  |
| (f) | Public Comment (2 minutes/person)   |   |

**Lunch**  
**12:00 PM – 1:20 PM**

**Zero Emission Technology Progress II**  
**Moderator - Fan Xu, Ph.D., Program Supervisor\***

**2. 1:30 PM – 3:15 PM**

- |     |  |  |
|-----|--|--|
| (a) | California Hydrogen Systems Analysis   | Lewis Fulton, Ph.D., Director of Sustainable Transportation Energy Pathways Program, University of California, Davis                           |
| (b) | Completion of Battery Electric Truck Demonstration – SWITCH-ON Project                                   | Michael Ippoliti, Senior Leader Public Partnerships, Volvo Group North America   |
| (c) | Data-Driven Planning Platforms for Charging Networks, Truck Fleets, and Power Systems: A Progress Report | Nanpeng Yu, Ph.D., Professor of Electrical and Computer Engineering, UCR & Jonathan Shi, Founding Full Stack Software Engineer, AmpTrans, Inc. |
| (d) | Battery Value Chain: Accelerating Electrification and Driving Circularity for a Better Tomorrow          | Anna Axelsson, Head of Battery Industrialization and Logistics, Volvo Energy North America   |
| (e) | Feedback and Discussion  | Advisors and Experts   |
| (f) | Public Comment (2 minutes/person)  |  |

**Break (Networking/Coffee)**  
**3:15 PM – 3:45 PM**

**3. Wrap-up**  
**3:45 PM – 4:30 PM**

- |     |  |                               |
|-----|--|-------------------------------|
| (a) | 2026 Clean Fuels Plan Update & Wrap-up | Vasileios Papapostolou, Sc.D. |
| (b) | Advisor and Expert Comments            | All                           |

(c) Public Comment (2 minutes/person)

\* South Coast AQMD Technology Advancement Office

### **Other Business**

*Any member of the Advisory Group, or its staff, on his or her own initiative or in response to questions posed by the public, may ask a question for clarification; may make a brief announcement or report on his or her own activities, provide a reference to staff regarding factual information, request staff to report back at a subsequent meeting concerning any matter, or may take action to direct staff to place a matter of business on a future agenda. (Gov't. Code Section 54954.2)*

### **Public Comment Period**

*At the end of the regular meeting agenda, an opportunity is provided for the public to speak on any subject within the Advisory Group's authority that is not on the agenda. Speakers may be limited to two (2) minutes each.*

### **Document Availability**

*All documents (i) constituting non-exempt public records; (ii) relating to an item on the agenda for a regular meeting; and (iii) having been distributed to at least a majority of the Advisory Group after the agenda is posted, are available by contacting Donna Vernon at 909-396-3097 from 7:00 a.m. to 5:30 p.m., Tuesday through Friday, or send the request to [dvernon@aqmd.gov](mailto:dvernon@aqmd.gov).*

### **Americans with Disabilities Act**

*Disability and language-related accommodations can be requested to allow participation in the Clean Fuels Program Advisory Group meeting. The agenda will be made available, upon request, in appropriate alternative formats to assist persons with a disability (Gov't Code Section 54954.2(a)). In addition, other documents may be requested in alternative formats and languages. Any disability or language-related accommodation must be requested as soon as practicable. Requests will be accommodated unless providing the accommodation would result in a fundamental alteration or undue burden to South Coast AQMD. Please contact Donna Vernon at 909-396-3097 from 7:00 a.m. to 5:30 p.m., Tuesday through Friday, or send the request to [dvernon@aqmd.gov](mailto:dvernon@aqmd.gov).*

## **INSTRUCTIONS FOR ELECTRONIC PARTICIPATION**

### **Instructions for Participating in a Virtual Meeting as an Attendee**

As an attendee, you will have the opportunity to virtually raise your hand and provide public comment.

Before joining the call, please silence your other communication devices such as your cell or desk phone. This will prevent any feedback or interruptions during the meeting.

Please note: During the meeting, all participants will be placed on Mute by the host. You will not be able to mute or unmute your lines manually.

After each agenda item, the Chairman will announce public comment.

Speakers will be limited to a total of three (3) minutes for the Consent Calendar and Board Calendar, and three (3) minutes or less for other agenda items.

A countdown timer will be displayed on the screen for each public comment.

If interpretation is needed, more time will be allotted.

**Once you raise your hand to provide public comment, your name will be added to the speaker list. Your name will be called when it is your turn to comment. The host will then unmute your line.**

### **Directions for Video ZOOM on a DESKTOP/LAPTOP:**

- If you would like to make a public comment, please click on the **“Raise Hand”** button on the bottom of the screen.
- This will signal to the host that you would like to provide a public comment and you will be added to the list.

**Directions for Video Zoom on a SMARTPHONE:**

- If you would like to make a public comment, please click on the **“Raise Hand”** button on the bottom of your screen.
- This will signal to the host that you would like to provide a public comment and you will be added to the list.

**Directions for TELEPHONE line only:**

- If you would like to make public comment, please **dial \*9** on your keypad to signal that you would like to comment.



# 2025 Incentives & Grant Updates

Mei Wang



# Main Incentive Programs



## Carl Moyer Program

- HD trucks
- Off-Road/Construction/Ag
- Marine vessels
- Locomotives
- Cargo handling equipment
- Infrastructure
  
- 1998 to Present



## Proposition 1B Goods Movement

- HD trucks
- Cargo handling equipment
- Transport Refrigeration Units (TRU)
- Locomotives
- Shore power
- 2009 to Present



## Lower-Emission School Bus Program

- School buses replacement,
- infrastructure
- CNG tank replacements
  
- 2001 to Present



## Replace Your Ride

- Light-duty vehicles
- EV chargers
- E-Bikes
- Alternative options (transit passes, car sharing, fuel cards)
  
- 2015 to Present

# Other Incentive Programs



**Voucher Incentive Program**  
(for small fleets with 20  
or fewer vehicles)



**Funding Agricultural  
Replacement Measures for  
Emission Reductions  
(FARMER) Program**



**Volkswagen Environmental  
Mitigation Trust Program**



**Commercial Electric Lawn  
and Garden  
Equipment Program**



**Community Air Protection  
Program (supports AB 617)**



# Carl Moyer Program Updates

- At the 27th year of program implementation
- Emissions Reduced (TPY) NOx: 9,242, PM: 263
- \$652 million of funds liquidated (Year 1-23) and over 9,100 engines upgraded
- Years 24 through 27 are in various stages of implementation, totaling \$ 173 million

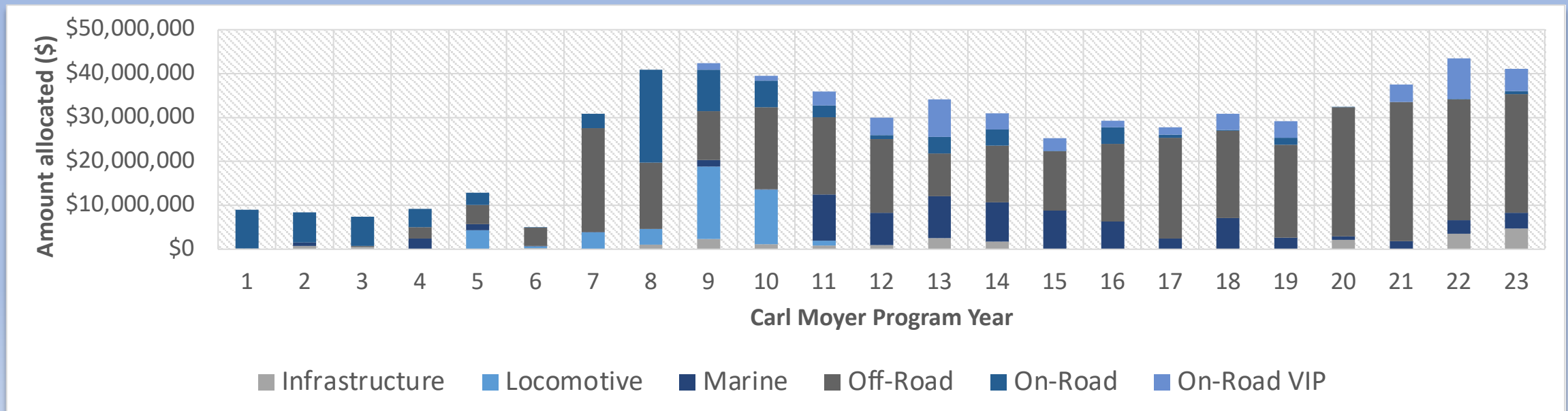

# Carl Moyer Program Year 23 Liquidated June 2025

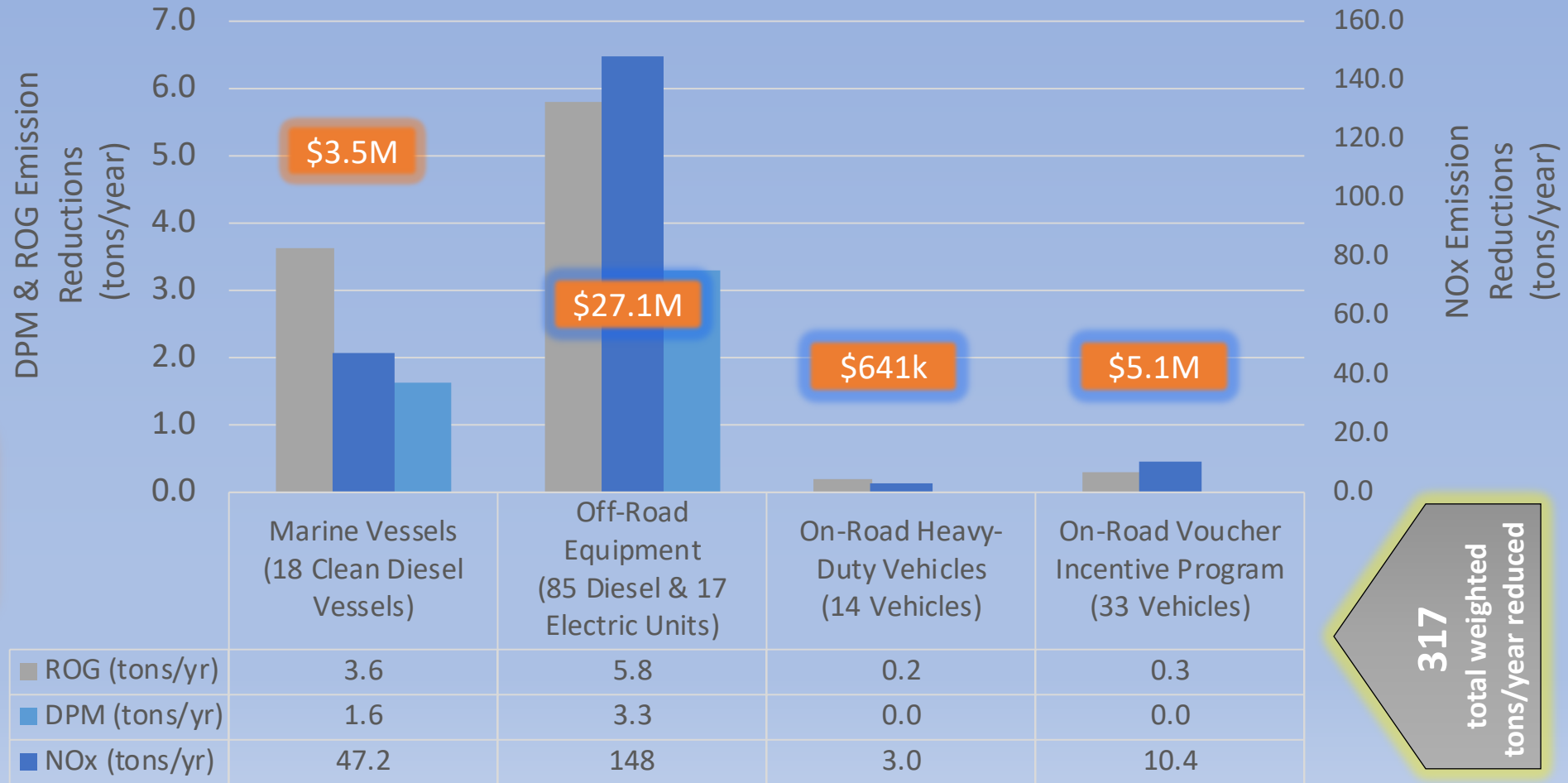
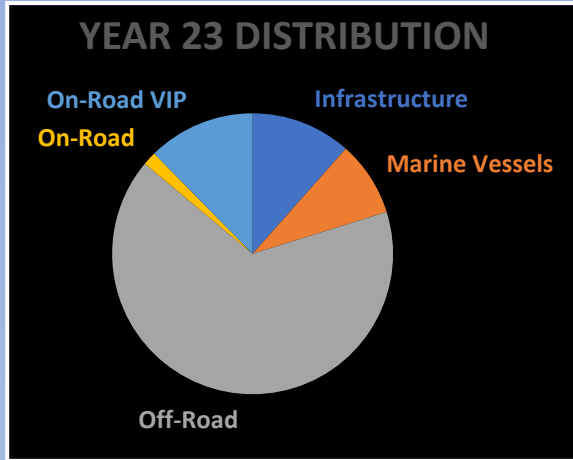

Approximately  
**\$41.1 Million**  
In Total Funding Implemented

Approximately  
**\$4.75 Million**  
Spent on Charging Infrastructure  
Projects, which have no emission  
reduction estimates



# Carl Moyer Program Updates

- \$200 million of Carl Moyer and Community Air Protection Funds were allocated to support zero-emission vehicle and equipment infrastructure projects
- 6 hydrogen stations were awarded
- Approximately 1000 chargers are expected to be installed across the Basin
- Charger capacity: 60 kW - 1MW
- Some sites will have NZE and ZE on-site power generation

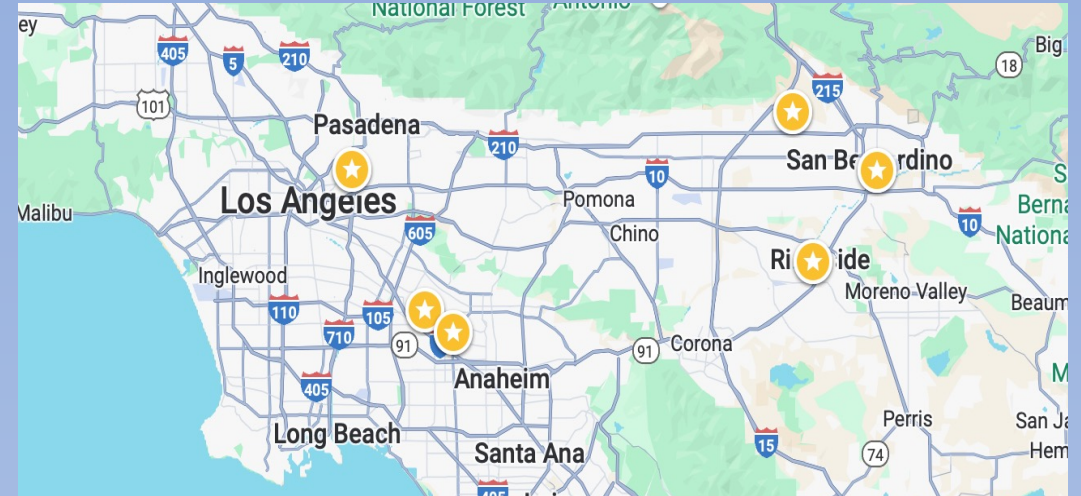

H2 station Locations





# Carl Moyer Program Updates

Carl Moyer Year 27 Solicitation closed in July 2025

Funding Available: \$47 million

Total requests: \$588 million

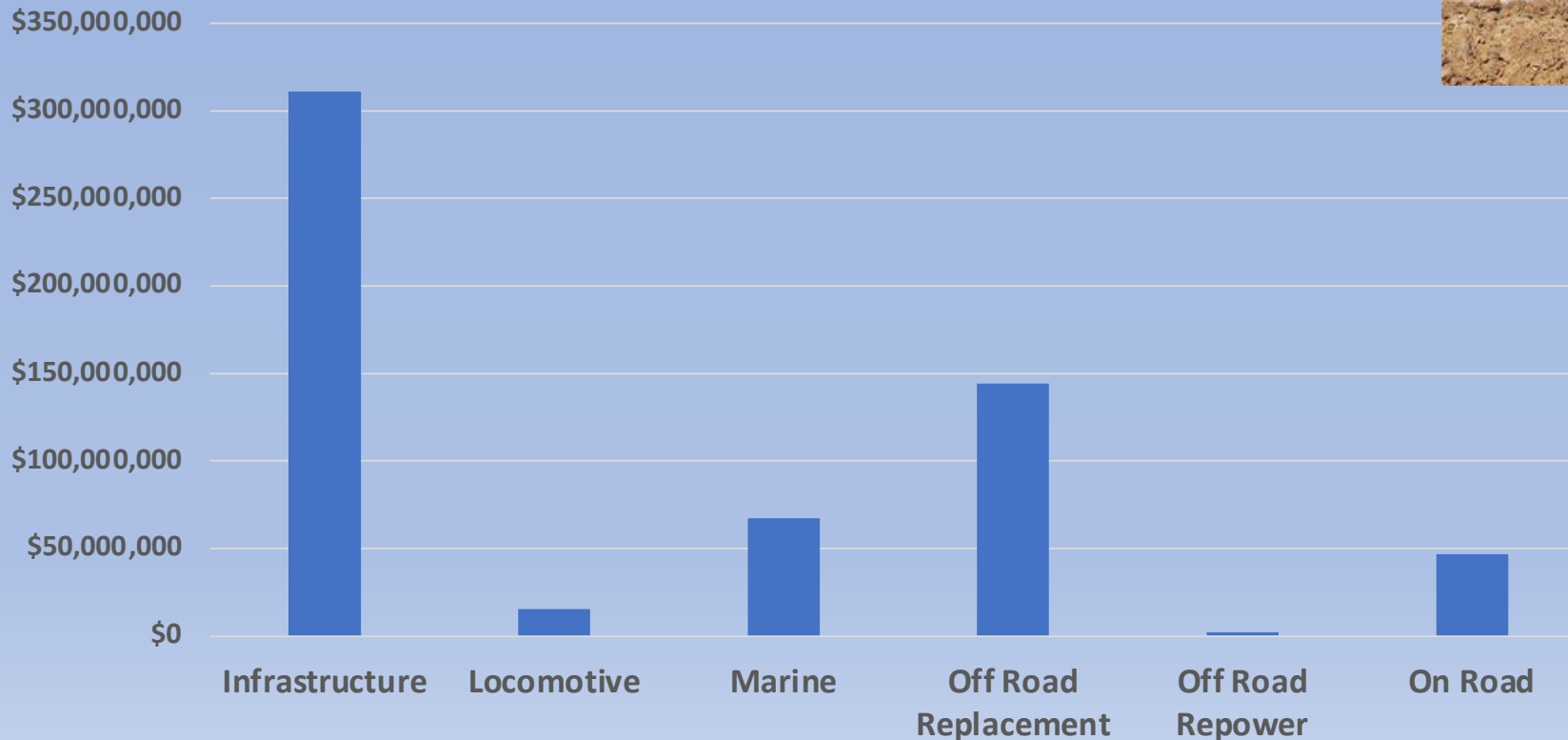



Carl Moyer Program  
 Cost-Effectiveness Average  
 Range: \$20k - \$363k



Source Category	Reduced Engine Type	Average of Cost Effectiveness
Marine Vessels	Diesel	\$24,925.70
Off-Road Equipment - Cargo Handling	Diesel	\$26,413.62
Off-Road Equipment - Construction	Diesel	\$23,984.58
Off-Road Equipment - Mobile Agricultural	Diesel	<u>\$20,275.25</u>
Off-Road Equipment - Other	Diesel	\$32,427.23
Off-Road Equipment - Other	Electric	\$66,678.60
On-Road Heavy-Duty Vehicles	CNG	\$67,359.99
On-Road Voucher Incentive Program	CNG	\$172,134.01
On-Road Voucher Incentive Program	Diesel	\$20,480.18
On-Road Voucher Incentive Program	Electric	<u>\$363,098.16</u>

# VW Mitigation Program

- Inception in 2019
- Over 1,300 equipment/vehicle projects received, requesting \$184.7 million
- To date, 520 eligible equipment/vehicles have been approved, totaling \$106.9 million
- PA 2024-03 opened in March 2024
  - project categories include:
    - Combustion Freight and Marine Projects (approx. \$2M still available)
    - Zero-Emission Class 8 Freight and Port Drayage Trucks (oversubscribed; new applications are waitlisted)



# Proposition 1B Goods Movement Program

- Inception in 2009
- \$485 Million in Funding
- Replacing Diesel Equipment
- More than 7,300 vehicles/equipment replaced
- Emissions Reduced (TPY) NOx: 7,086, PM: 220
- Approximately \$50 million remains from withdrawn projects
- New Solicitation anticipated to be released in Q4 2025 for Cargo Handling and TRUs\*

\*Pending Governing Board approval

# Lower Emission School Bus Program



Since 2001, South Coast AQMD has funded over \$325M to:

- Replaced over 1,900 diesel school buses with lower emission CNG/Propane
- Retrofitted 3,400 diesel school buses with PM traps



2021 school bus awards awarded over \$43M to:

- Replaced over 178 pre-2001 diesel school buses with lower emission and ZE
- Over 46 public school districts funded



2025 joint solicitation for LESBP, CARE4Kids, Carl Moyer Program

- Over \$65M in applications received, school buses (ZE only) and infrastructure
- Over 33 public school districts applied and over 220 ZE buses
- Expect the Board award in November 2025



# Replace Your Ride

Program Inception in 2015

Light Duty Vehicle Scrap & Replace Program

Over 13,400 vehicles replaced and \$110 million spent

Alternative Mobility and E-Bike Options

Average retired vehicle – 23 years old

88% of participants at lowest poverty level

Up to \$12,000 incentive for Zero-Emission Vehicles

38 tons NOx & 1.9 tons PM Reduced Annually



# Community Air Protection Program (CAPP)

- Support Goals of AB 617
- Approved by Governor as part of the State budget each year



Approximately  
**\$1.26 Billion**  
In Total Funding

South Coast AQMD  
Received Approximately  
**\$551.8 Million**  
In Total Funding

South Coast AQMD  
Awarded Approximately  
**\$260.5 Million**  
In Total Funding

## HISTORIC ALLOCATION

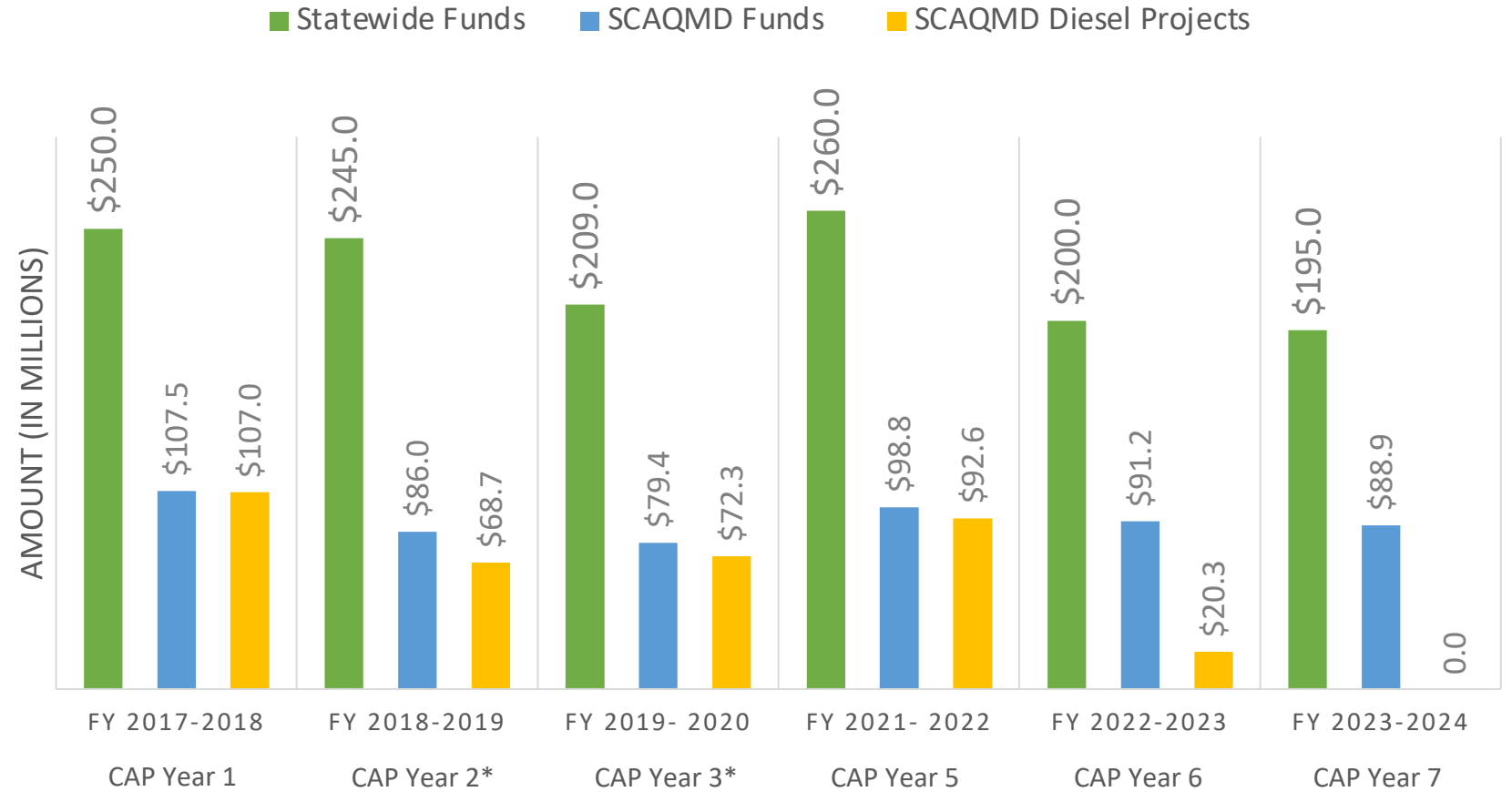

\*Other Projects awarded under CAP Year 2 & 3, including air filtration, Green Spaces, and Truck Loaner Programs, are not included in the above table. Only funds allocated for the Carl Moyer projects are shown here.



# New Incentive Programs

\$417 million in Funding  
Solicitations are currently open  
Website: <https://investclean.org>



**Heavy-Duty Charging Infrastructure**  
**\$191 million**



**Class 8 Heavy-Duty Trucks and Last Mile Freight for Class 4 and 5 Vehicles**  
**\$84 million**



**Battery Electric Locomotives**  
**\$199 million**



**Cargo Handling Equipment**  
**\$26 million**

# New Incentive Programs

## Electric

- \$33.9 million available
- Replacing Class 6 and 7 vehicles with ZE
- Box trucks, TRU, step vans
- Currently accepting applications



## Care4Kids

- \$24.8 million available
- Replace class 7 and 7 school buses with ZE
- Solicitation closed award in November 2025

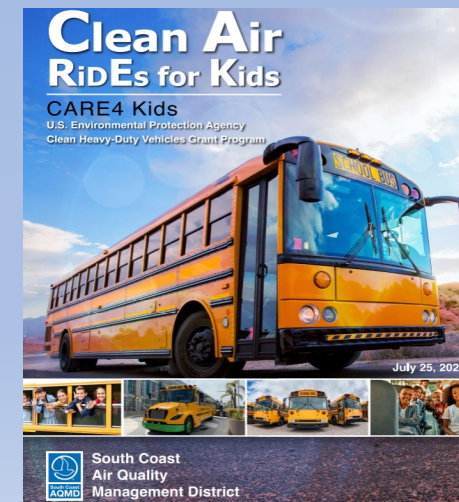



# Additional Funding Opportunities

## Incentive Program Funds:

- South Coast AQMD WAIRE Program: ~\$40 million
- South Coast AQMD Ocean Going Vessel At Berth Remediation Funds: ~\$40 million
- Community Air Protection Year 8 Funds: \$75 million (South Coast AQMD allocation)
- Prop1B Program: \$50 million
- State Reserved:\$5.2 million

## Potential Demonstration Funds:

- US EPA Targeted Airshed Grant: \$270 million



# Questions



# The Social Value of Electrolytic Hydrogen



**UCI**

Robert Flores, Mariam Al Moubasher,  
Jack Brouwer, Jeff Reed  
Clean Energy Institute, UC Irvine



# Hydrogen is Essential for Sustainability

## Chemicals & Materials

Ammonia Production

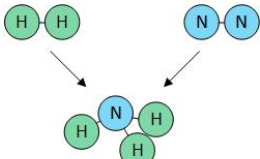

Iron Ore Reduction

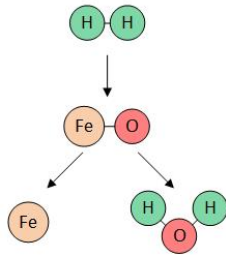

## High Temperature Heat

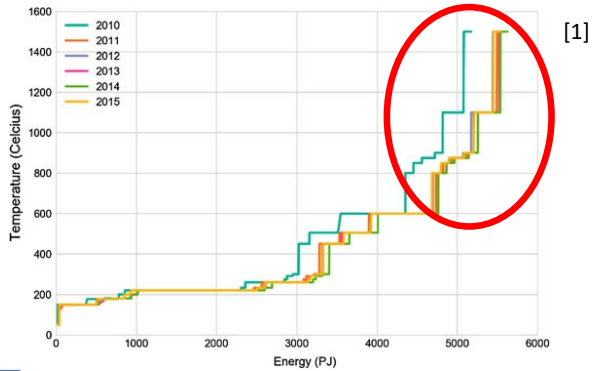

## Heavy Duty Transportation

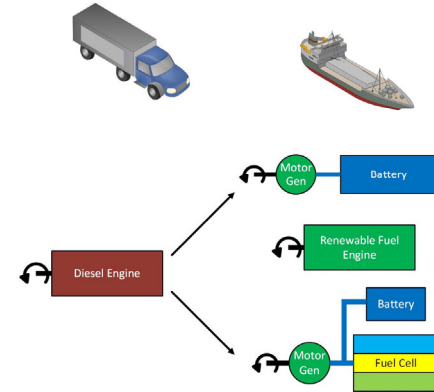

## Reliable & Sustainable Electricity

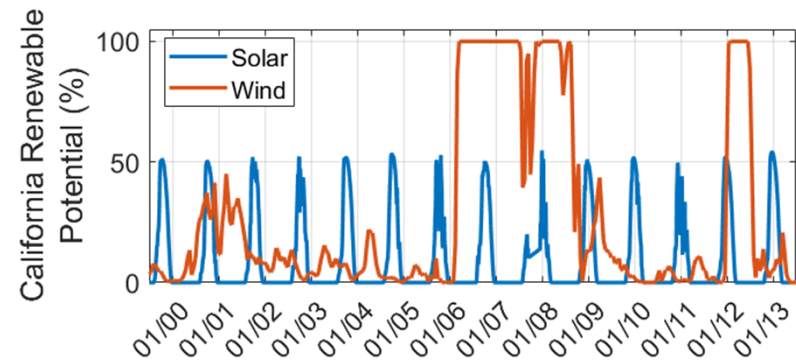

# Where Should We Use Renewable H<sub>2</sub>?

**Global Carbon Emissions by End Use<sup>[1]</sup>**

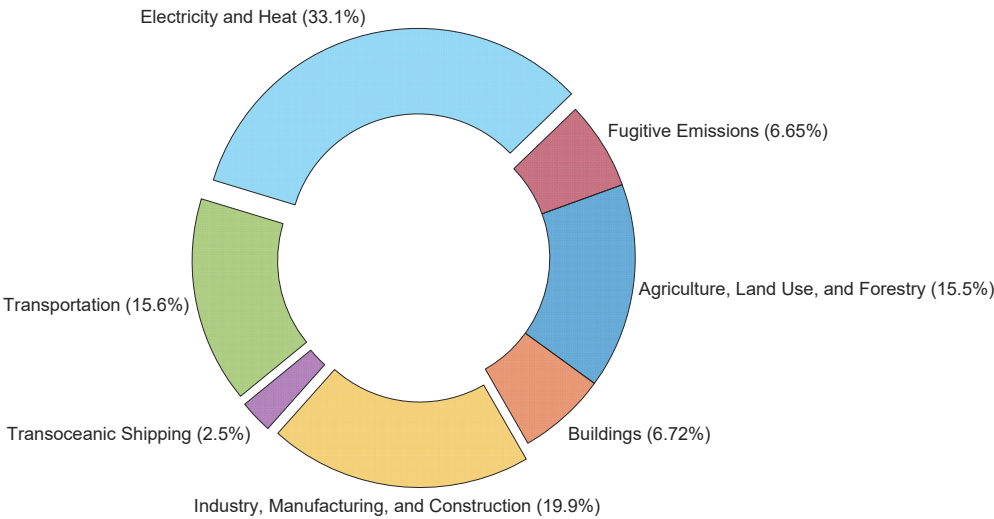

**Total Cost – Illustrative Only**

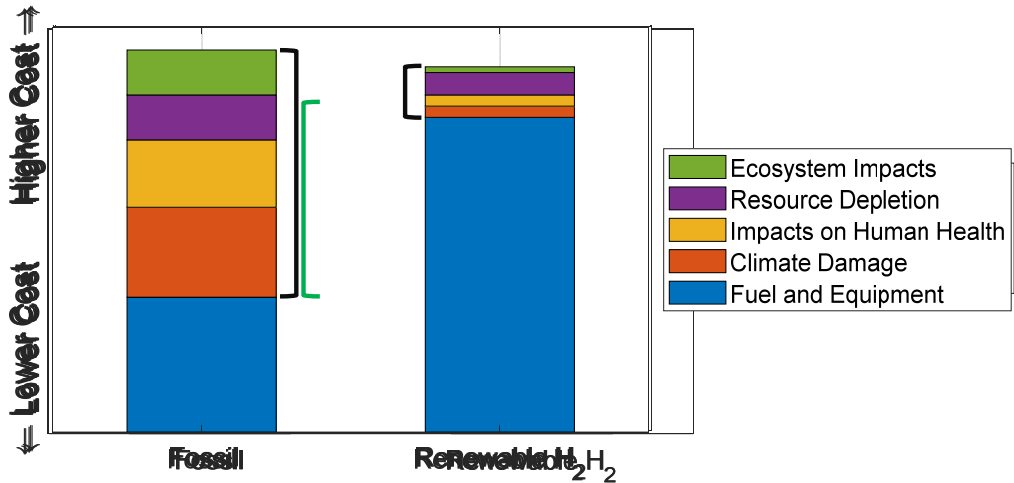

- Brackets capture “social cost”
- Difference between brackets – “social value” of decarbonization

[1]: <https://ourworldindata.org/emissions-by-sector>





Conventional Fossil Processes for Comparison Against H<sub>2</sub> Produced Using 60% Wind / 40% Solar Electricity Mix

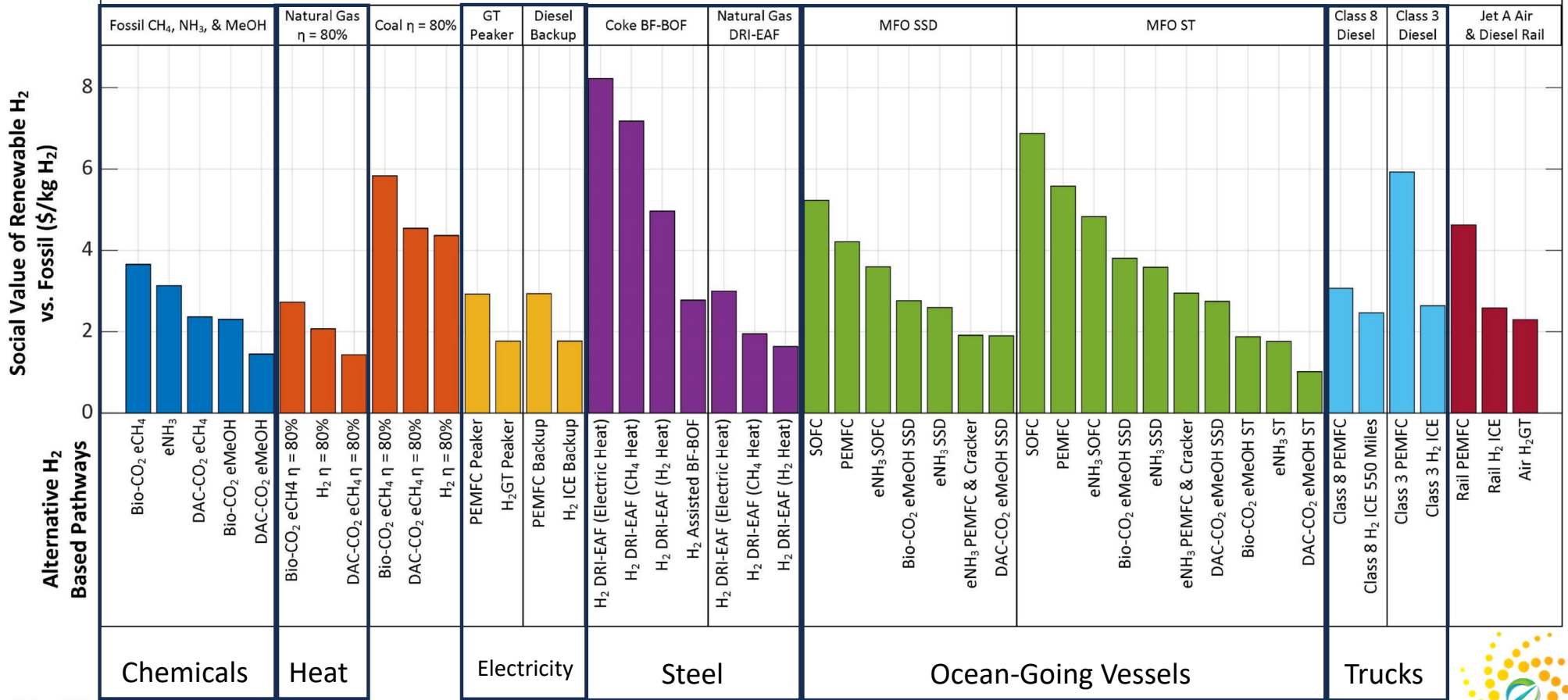

Energy intensive processes using coal or oil vs. More efficiency natural gas processes



## Social Value and Electric Grid Mix

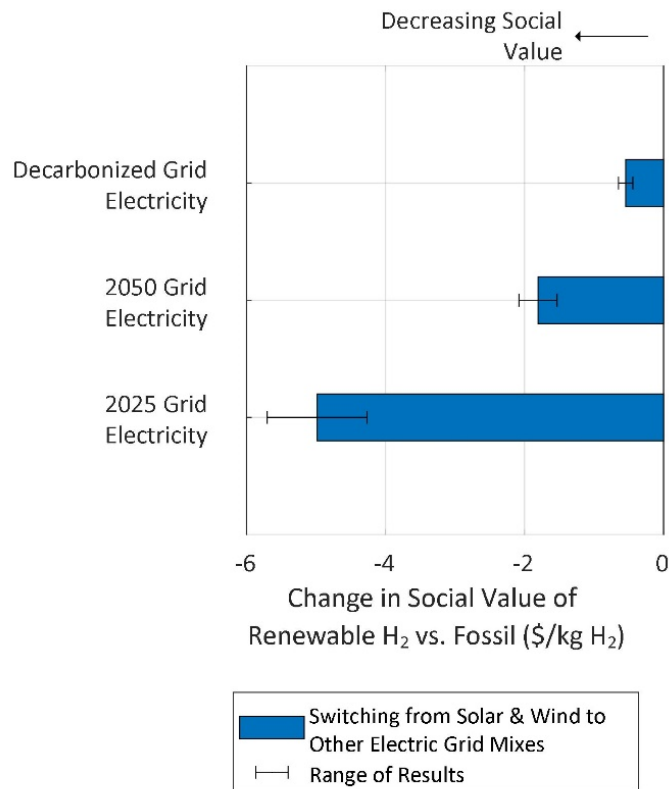

Social value disappears quickly if fossil generation powers electrolysis

## Hydrogen vs. Electrification (Trucks Example)

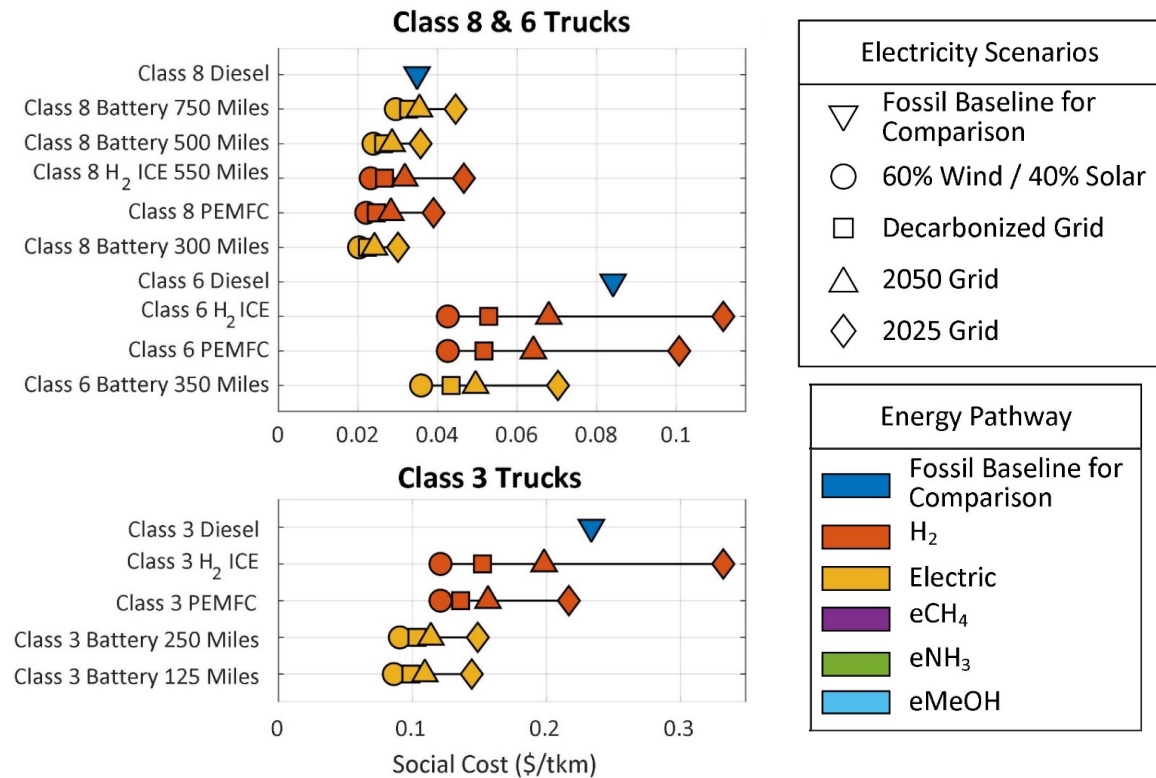

When feasible, direct electrification leads to better societal outcomes



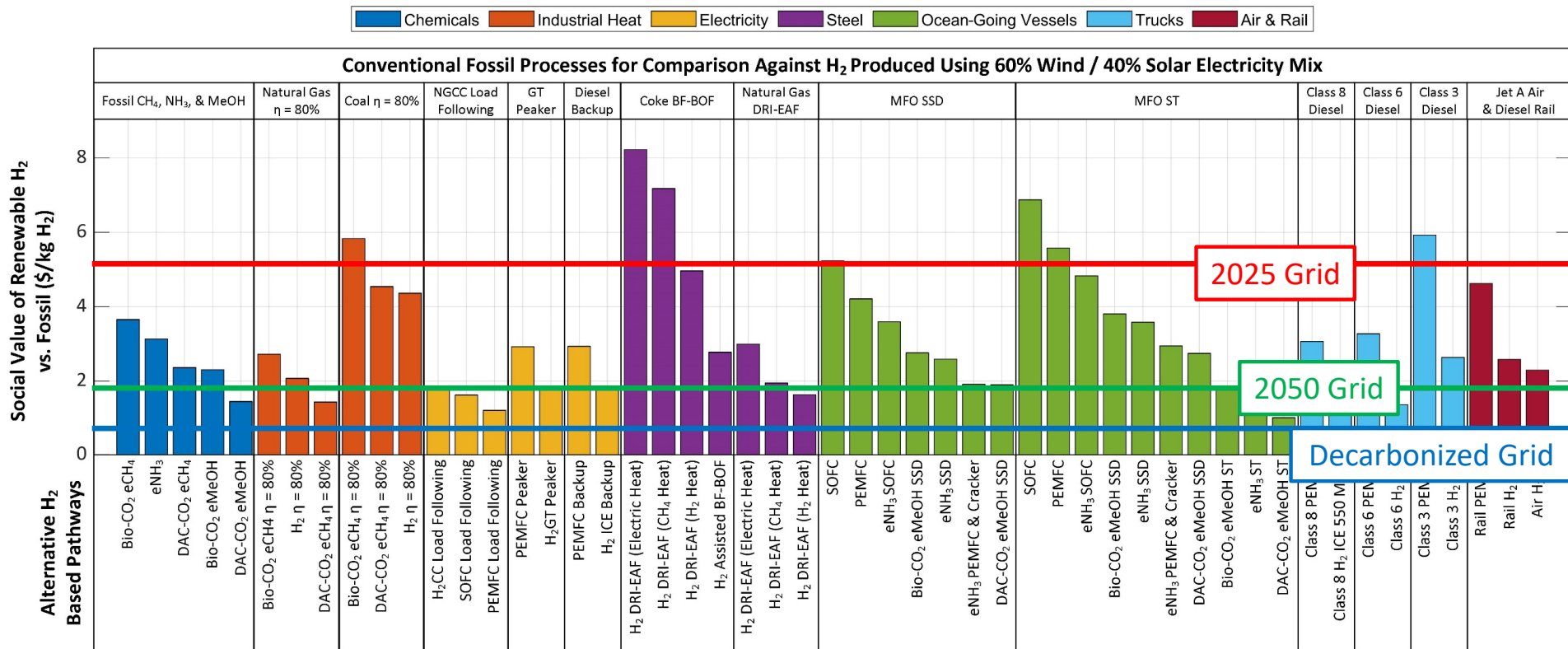

Acknowledgements to Plug Power Inc. for funding this work, to Tim Cortes and Luke Wentlent at Plug Power for their feedback, and Julie Schoenung at Texas A&M.



# Thank You!



Robert Flores, Mariam Al Moubasher,  
Jack Brouwer, Jeff Reed  
Clean Energy Institute, UC Irvine



UCI

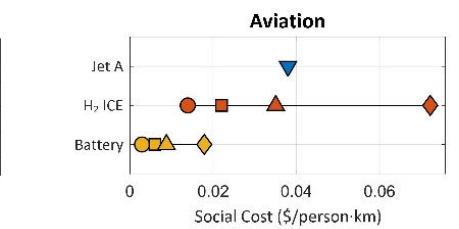
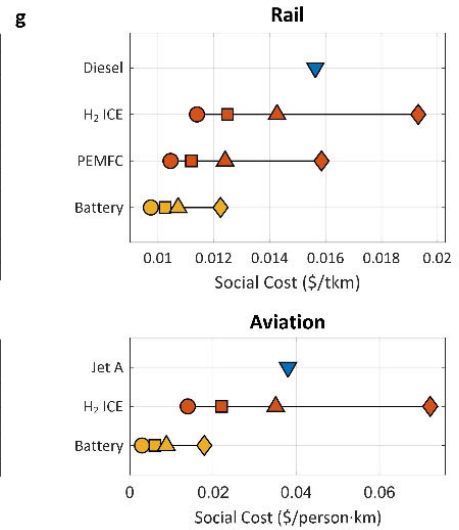
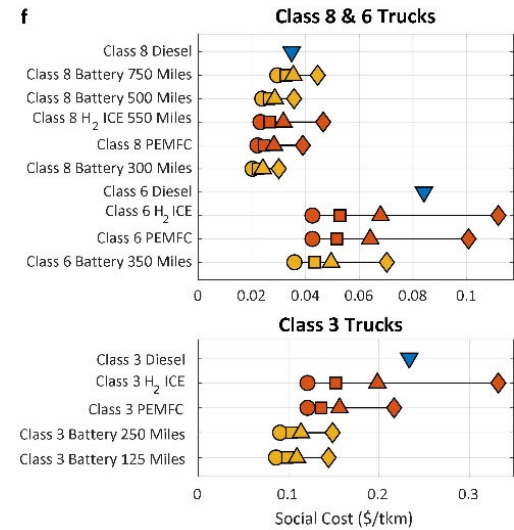
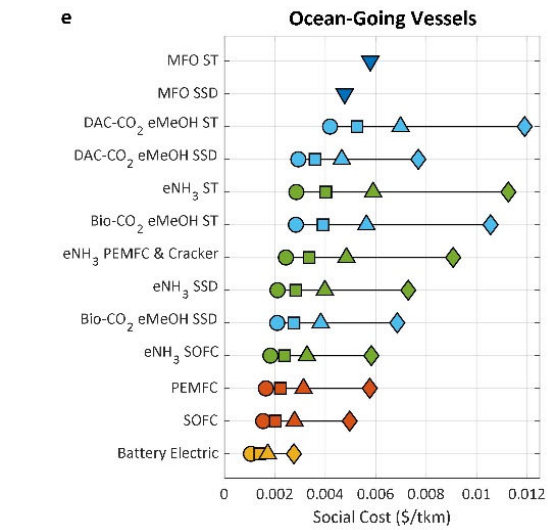
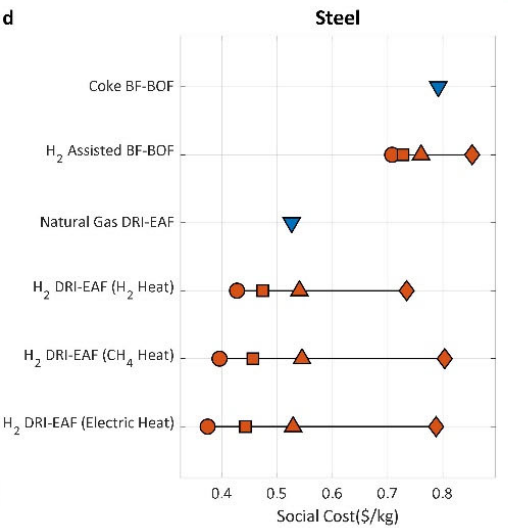
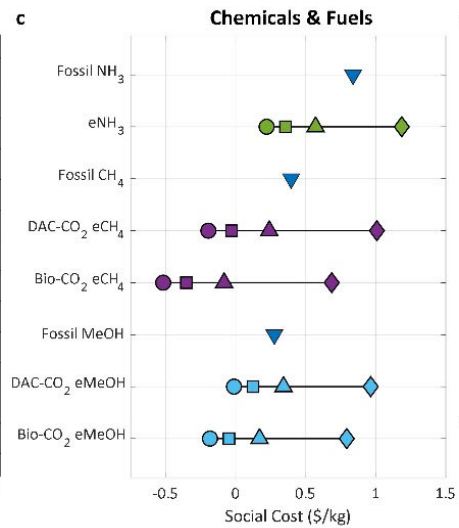
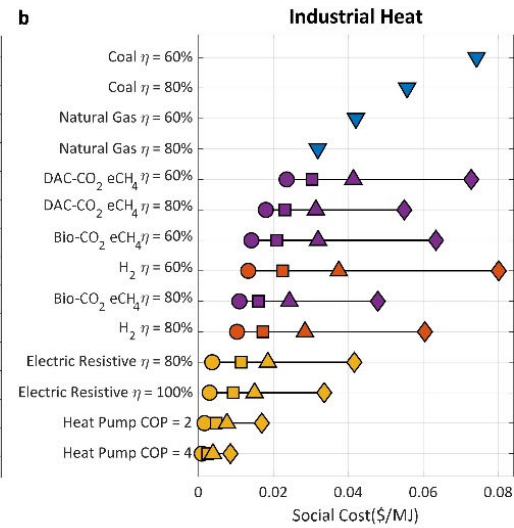
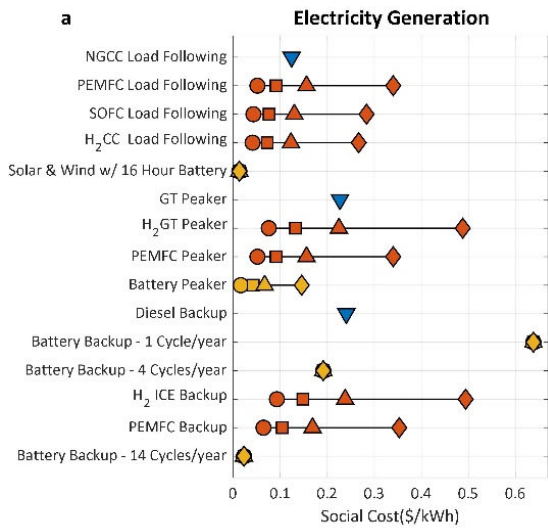

Electricity Scenarios	Energy Pathway
▽ Fossil Baseline for Comparison	■ Fossil Baseline for Comparison
○ 60% Wind / 40% Solar	■ H <sub>2</sub>
□ Decarbonized Grid	■ Electric
△ 2050 Grid	■ eCH <sub>4</sub>
◇ 2025 Grid	■ eNH <sub>3</sub>
	■ eMeOH

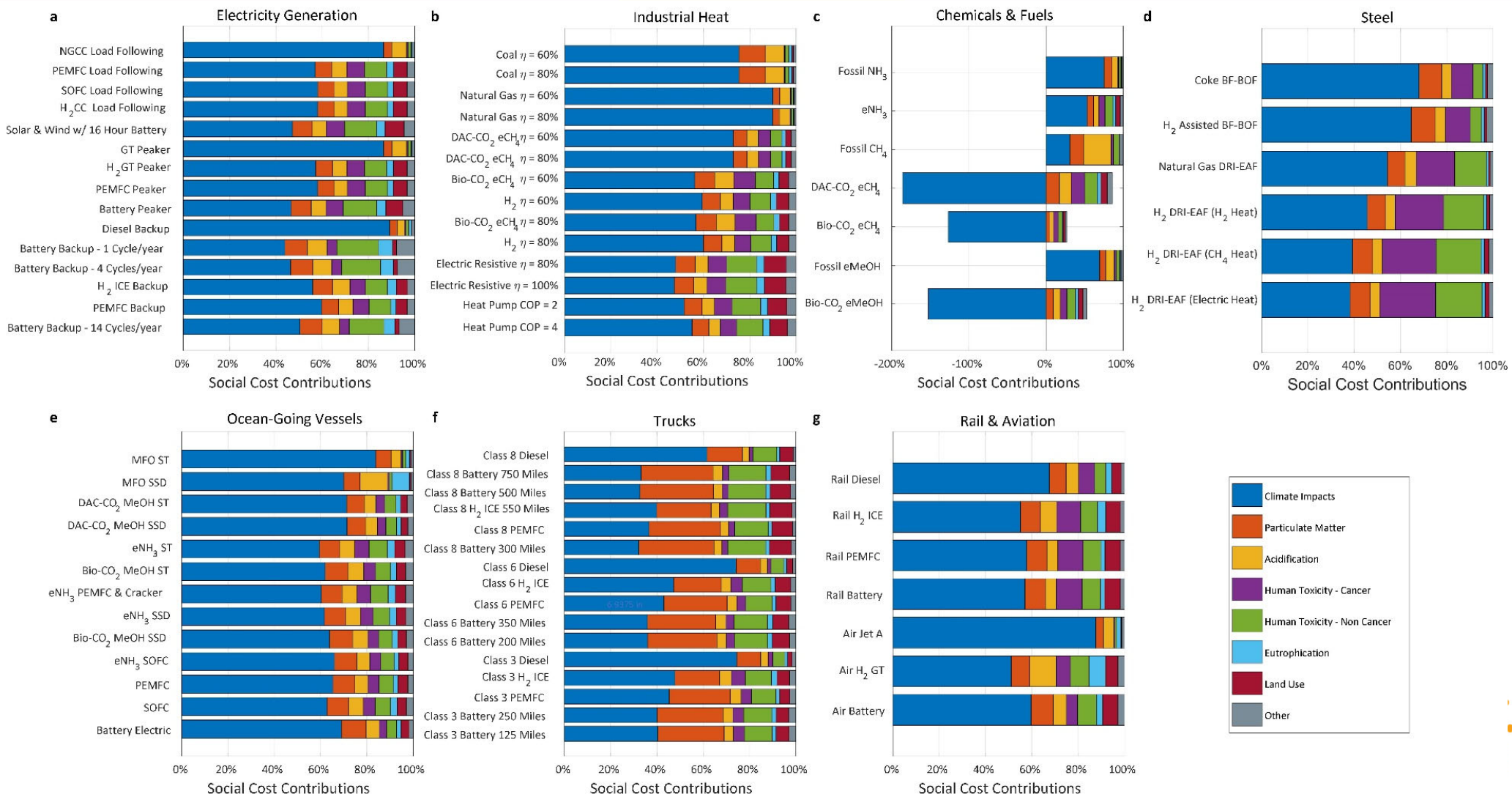

Electric Grid Mix	Change in Social Value from Gaseous H <sub>2</sub> Leakage (\$/100 g H <sub>2</sub> )	% of Social Value Change Attributable to Gaseous H <sub>2</sub> GWP	Change in Social Value for Liquid H <sub>2</sub> Leakage (\$/100 g LH <sub>2</sub> )	% of Social Value Change Attributable to Liquid H <sub>2</sub> GWP
2025	-\$0.91	40	-\$1.04	34
2050	-\$0.60	60	-\$0.66	55
Decarbonized Grid	-\$0.49	73	-\$0.52	69
Solar & Wind	-\$0.43	84	-\$0.44	81



- Iron & Steel
- Chemicals
- Heavy Duty Trucks
- Transoceanic Shipping
- Electricity Generation
- Industrial Heat

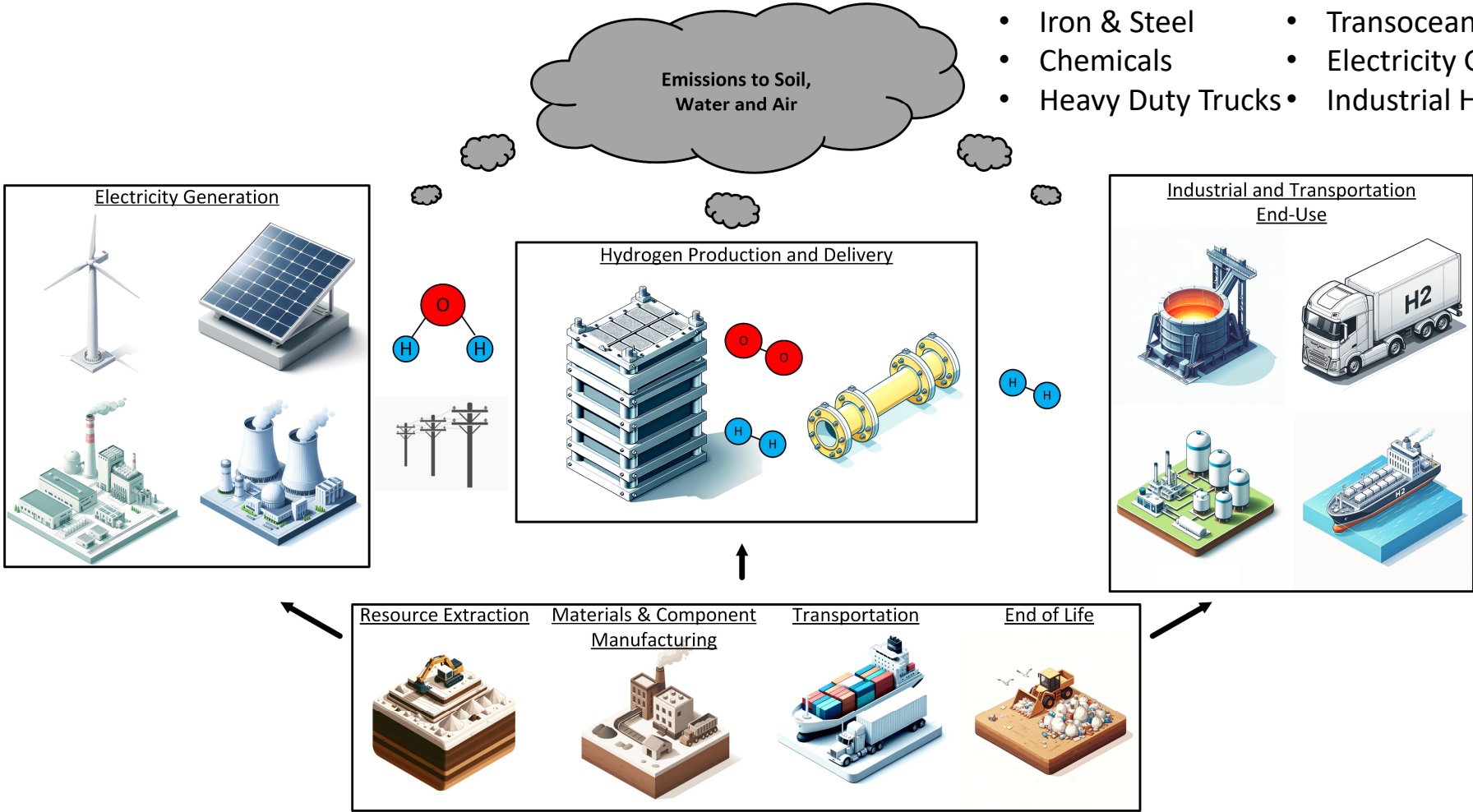

Source	Pros	Cons/Challenges
Conventional Life Cycle Analysis	<ul style="list-style-type: none"> <li>Existing and extensive literatures captures major HD transportation and industrial applications</li> <li>Includes water/resource impacts</li> <li>Includes a variety of well developed, peer reviewed models (examples):               <ul style="list-style-type: none"> <li>IPCC Climate Inventory (Climate change)</li> <li>World Meteorological Organization (O3 depletion)</li> </ul> </li> <li>Variety of methods and approaches</li> </ul>	<ul style="list-style-type: none"> <li>Linearization of complex nonlinear systems</li> <li>Snapshot in time</li> <li>Geographic dependencies</li> <li>Unit inconsistency</li> <li>Includes factors “to be applied with caution”:</li> <li>Reliance on aging studies</li> <li>Different methods/approaches tend to be opaque</li> <li>European</li> </ul>

**LCI Databases**

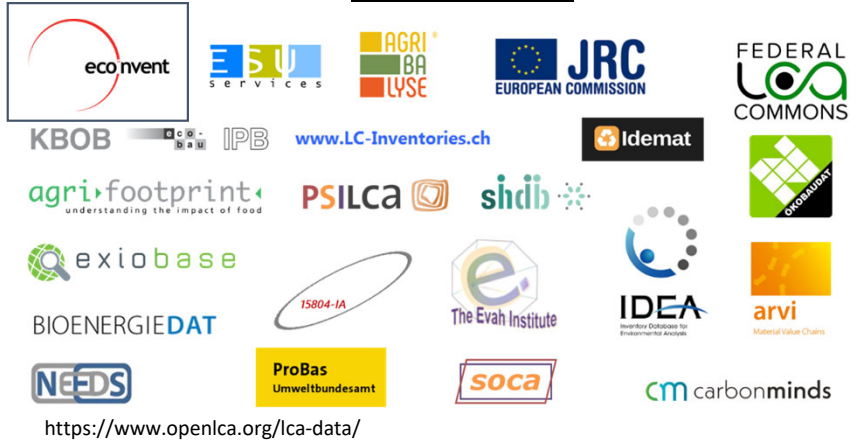

**LCIA Methods**

Method	Normalisation sets
CML-IA	World 1990, 1995, 2000; EU28, 2000; EU25, 2000; West Europe, 1995; Netherlands, 1997
ILCD Midpoint	EU-27, 2010 (available soon)
IMPACT 2002+	Europe, 2000
ReCiPe	Europe, 2000; World, 2000
BEES+	USA, 1997
TRACI	US-Canada, 2008; US, 2008; Canada, 2008
USEtox	Europe, 2004; North America, 2002/2008

<https://pre-sustainability.com/articles/the-normalisation-step-in-lcia/>

\*Acknowledgment: Prof. Julie Schoenung and WISDOM Institute: <https://sites.uci.edu/wisdom/members/>



# ***THE IMPACT OF VEHICLE-TO-HOME (V2H) TECHNOLOGY ON AIR QUALITY***

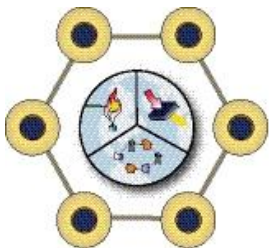

**ADVANCED POWER  
& ENERGY PROGRAM**  
UNIVERSITY of CALIFORNIA • IRVINE

*Dr. Kate Forrest  
Dr. Mike Mackinnon*

*17 September 2025*

## ***THE IMPACT OF VEHICLE-TO-HOME (V2H) TECHNOLOGY ON AIR QUALITY***

- **Goal: Quantify the Impact of Vehicle-to-Home (V2H) Technology on the Air Quality in the South Coast Air Basin**
- **Start Date: July 2025**
- **Duration: 24 months**
- **Project Team:**
  - **Professor Scott Samuelsen, PI**
  - **Dr. Kate Forrest**
  - **Dr. Michael Mac Kinnon**
  - **Dr. Shan Tian**



# Vehicle-to-Home

- **Vehicle-2-Home (V2H): Emerging Vehicle-Grid-Integration (VGI) Technology**
  - Discharge of energy stored in a PEV to power the home

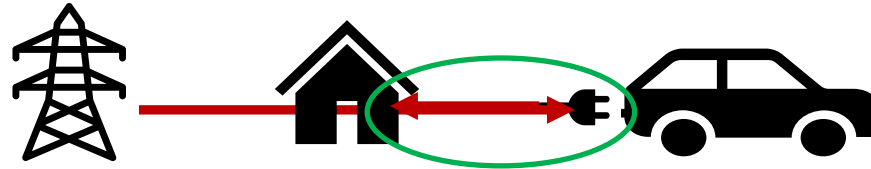

- ✓ Home battery system capacity: 10-15kWh
- ✓ PEV battery capacity: 60-100kWh

- **Key Benefits:**
  - Lowers electricity costs for homeowners
  - Eases stress on the electric grid
  - Reduces reliance on grid imports and enhances resilience during outages
  - Cuts NOx emissions from central and peaker plants
  - Offers clean alternative to combustion backup generators



# Vehicle-to-Home

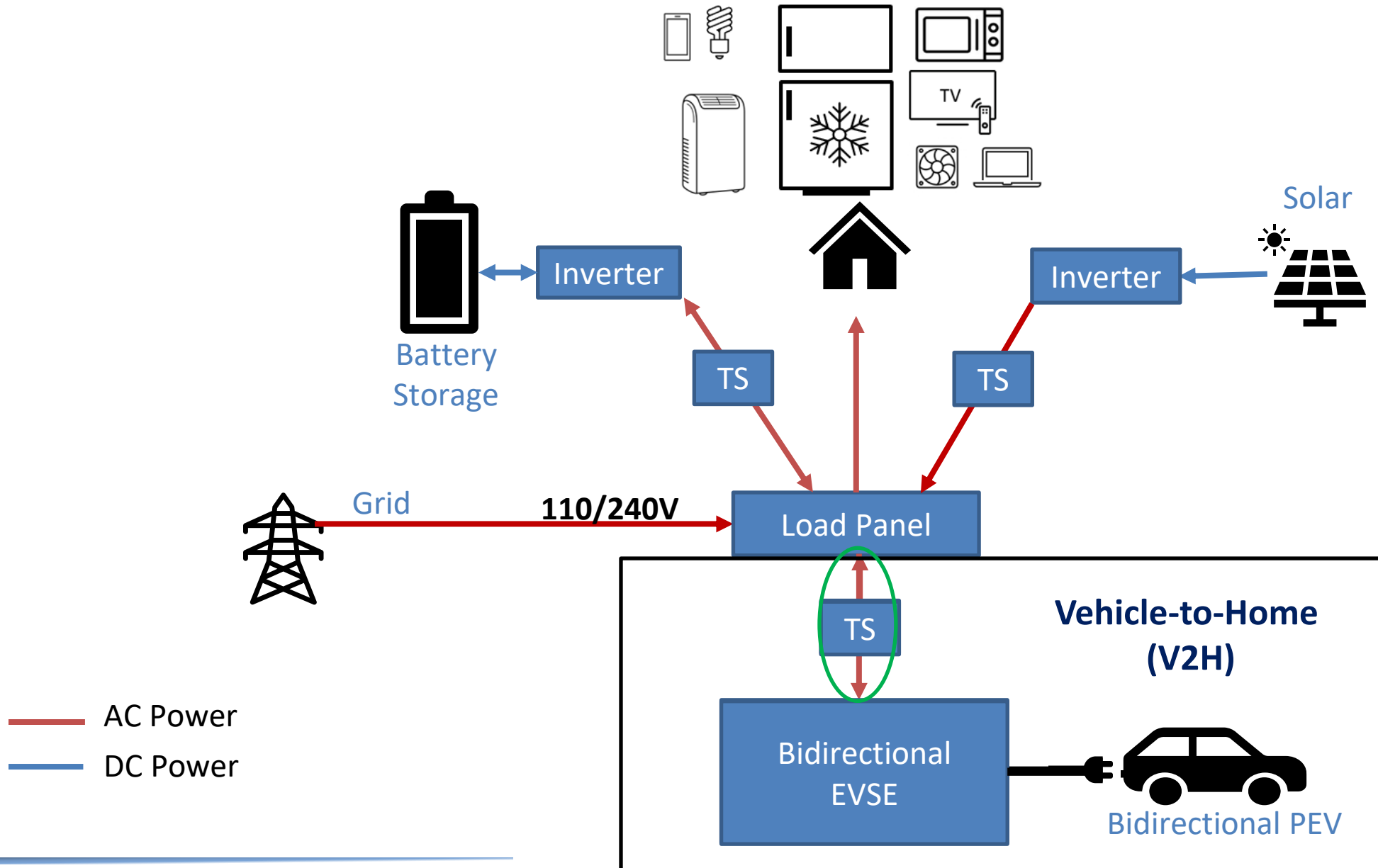

# Vehicle-to-Home



# Vehicle-to-Home

- **Optimization Model**

- **Cost Function:**

$$\min \left( \sum_{t=1}^T r_{TOU}(t) \times P_{in}(t) - r_{PPA}(t) \times P_{out}(t) \right)$$
$$P_{in}(t) - P_{out}(t) = l(t) - pv(t) + chg_{pev}(t) - dchg_{pev}(t) + chg_{bess}(t) - dchg_{bess}(t)$$

- **Home Battery Energy Storage System (BESS) Model**
  - **PEV Model**

- **Example**

- **All-electric home, 2906 sq ft**
  - **PV: 5.6 kW**
  - **Home Battery: 13 kWh**
  - **Time of Use (TOU)**
  - **PEV Battery: 77 kWh, SOC limits 20-80%**
  - **EVSE: 11 kW**



# Vehicle-to-Home

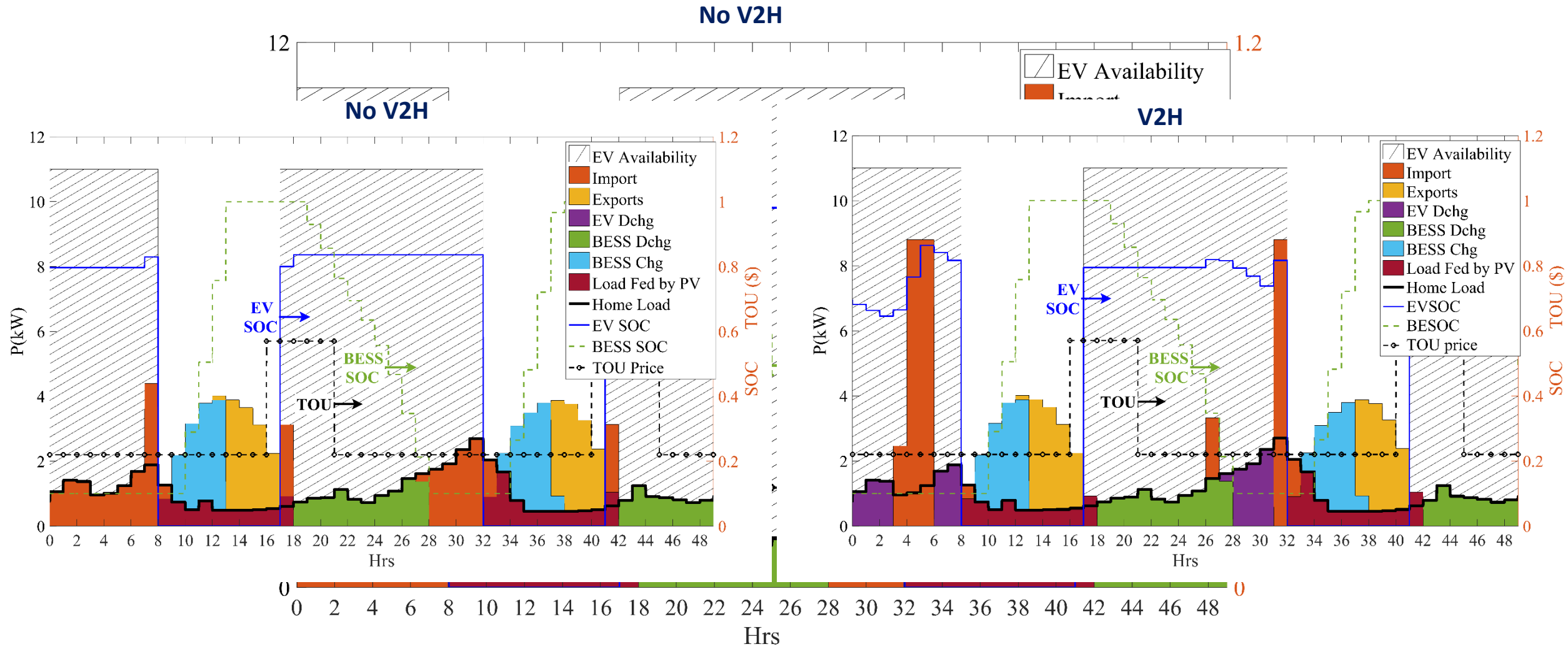

# Vehicle-to-Home

- **Vehicle-2-Home (V2H): Emerging Vehicle-Grid-Integration (VGI) Technology**
  - Discharge of energy stored in a PEV to power the home

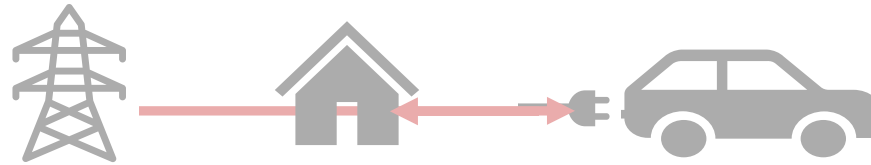

- ✓ Home battery system capacity: 10-15kWh
- ✓ PEV battery capacity: 60-100kWh

- **Key Benefits:**

- Lowers electricity costs for homeowners
- Eases stress on the electric grid
- Reduces reliance on grid imports and enhances resilience during outages

---

- **Cuts NOx emissions from central and peaker plants**
- **Offers clean alternative to combustion backup generators**



# Air Quality Impacts

## V2H expected to reduce pollutant emissions and improve air quality in the South Coast Air Basin including reductions in PM<sub>2.5</sub> and ground-level ozone

- Relieves pressure on the electrical grid which can reduce emissions from natural gas power plants
  - Particularly relevant for peaker plants which can be less efficient and higher emitting
- Offers homeowner a clean alternative to the use of high emitting combustion back-up generators

Current RBG fleet estimate (2022)

County	RBGs
LA	407802
RV	61224
SB	65009
OR	119618
Total	653653



Future RBG fleet estimate (2045)

County	RBGs in 2045
LA	517922
RV	83197
SB	91749
OR	149800
Total	842668

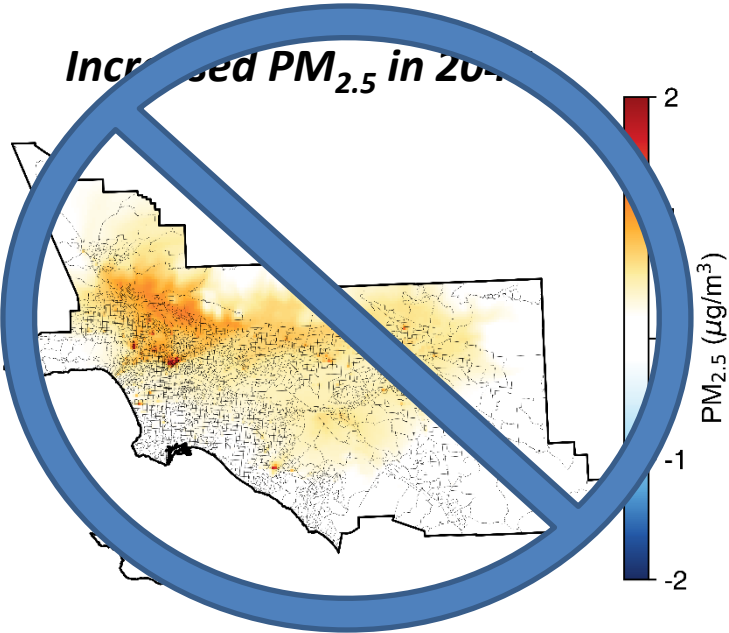

## APPROACH

Provide a detailed assessment of the air quality and public health benefits form in from the deployment of V2H in the South Coast Air Basin

- Quantify and value health benefits from improvements in outdoor air pollution
- Provide insight into health savings within socially and economically overburdened communities

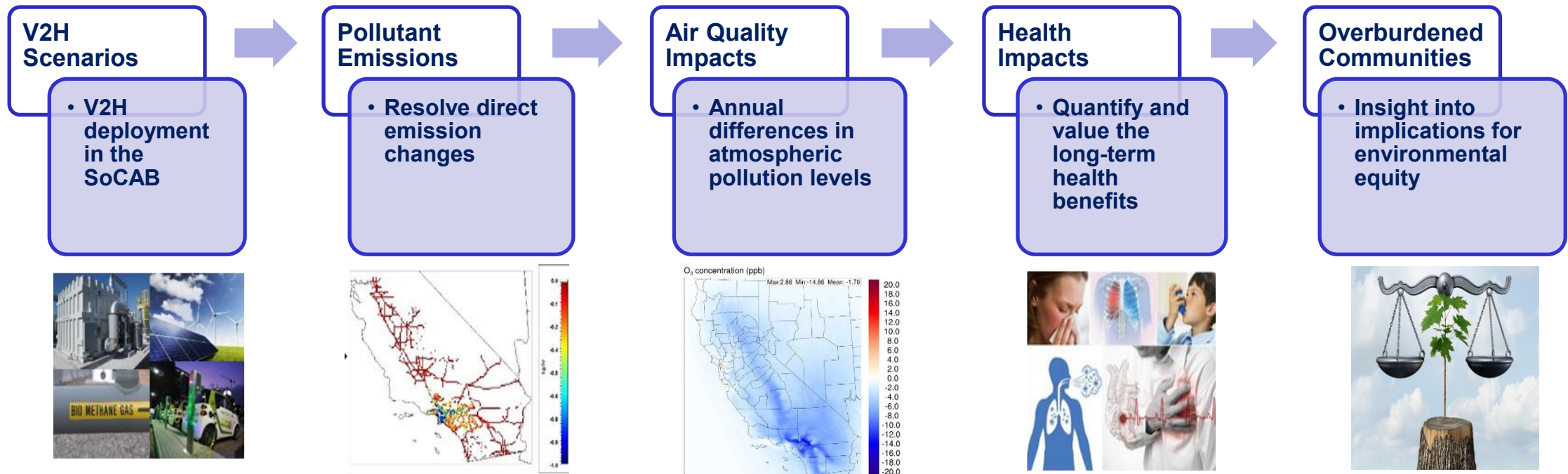

# Air Quality Impacts

## MODELING

Apply Community Multi-scale Air Quality Model (CMAQ) to develop a comprehensive understanding air pollution impact

- 1 km x 1 km horizontal resolution across the entire state
- Base year model performance validated using observational data
- Account for both primary (**emitted**) and secondary (**formed**) pollutants ( $O_3, PM_{2.5}$ )

Conduct annual simulations for 2045

- To provide a **comprehensive** understanding of the impacts experienced throughout the year on air quality from the emission reductions associated with V2H measures

	Model Version
Base Year Inventory	2020 CARB v0018
Emissions Processing	SMOKE v4.7 and ESTA
Air Quality Model	CMAQ v5.3.2
Chemical Mechanism	SAPRC-07 and AERO6
Biogenic Emissions	MEGAN v2.1
Meteorological Files	WRF-ARW v3.9.1
Boundary Conditions	CESM v2.1/CAM-chem

- Anthropogenic Emissions
- Biogenic Emissions
- Meteorology
- Topography
- Boundary Conditions

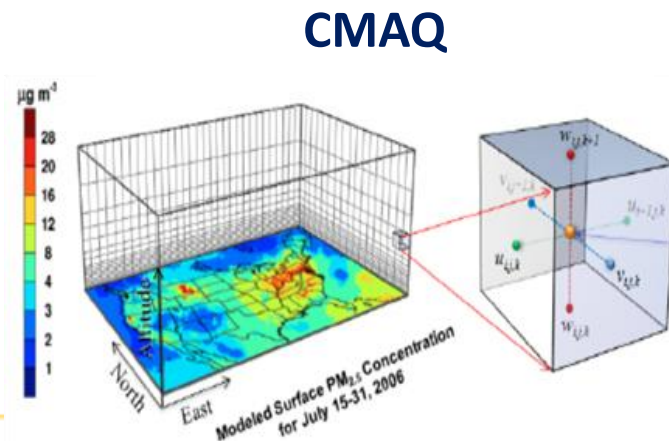

Annual Differences in  $PM_{2.5}$  and Ozone

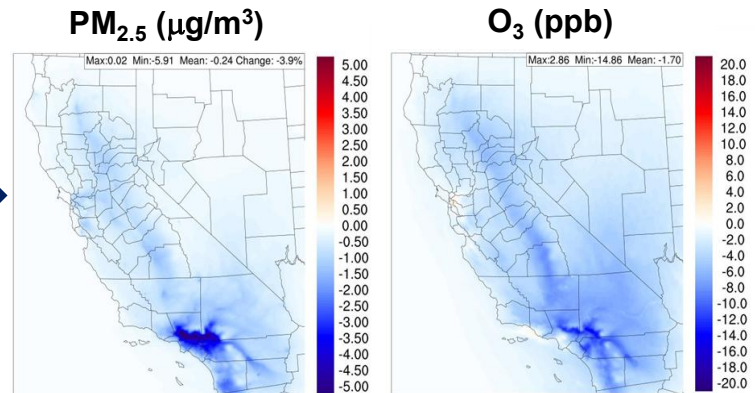

# ***THE IMPACT OF VEHICLE-TO-HOME (V2H) TECHNOLOGY ON AIR QUALITY***

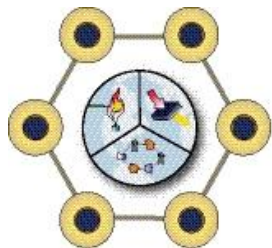

**ADVANCED POWER  
& ENERGY PROGRAM**  
UNIVERSITY of CALIFORNIA • IRVINE

*Dr. Kate Forrest  
Dr. Mike Mackinnon*

*17 September 2025*



# Estimating Community Air Quality Benefits from Electrification of Heavy-Duty Trucks in Inland Southern California

**Matthew Barth and Kanok Boriboonsomsin**

*College of Engineering – Center for Environmental Research and Technology  
University of California at Riverside*

**Clean Fuels Program Advisory Group Meeting**

*National Academies Beckman Center*

*September 17, 2025*



# Warehouse Trends in Inland Southern California

Larger in size

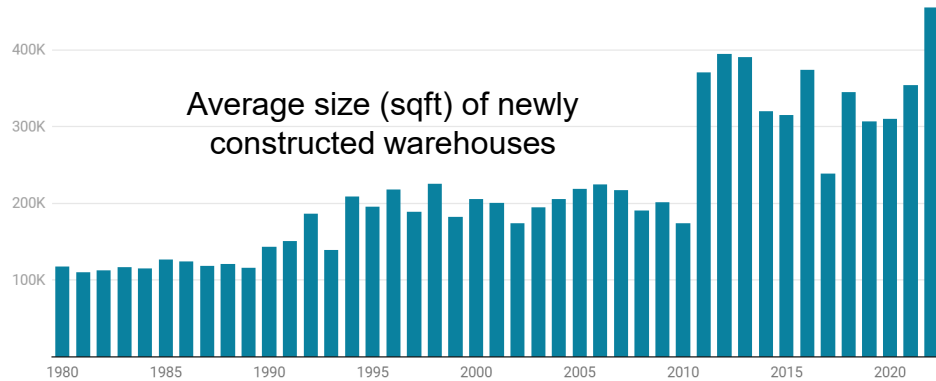

More concentrated

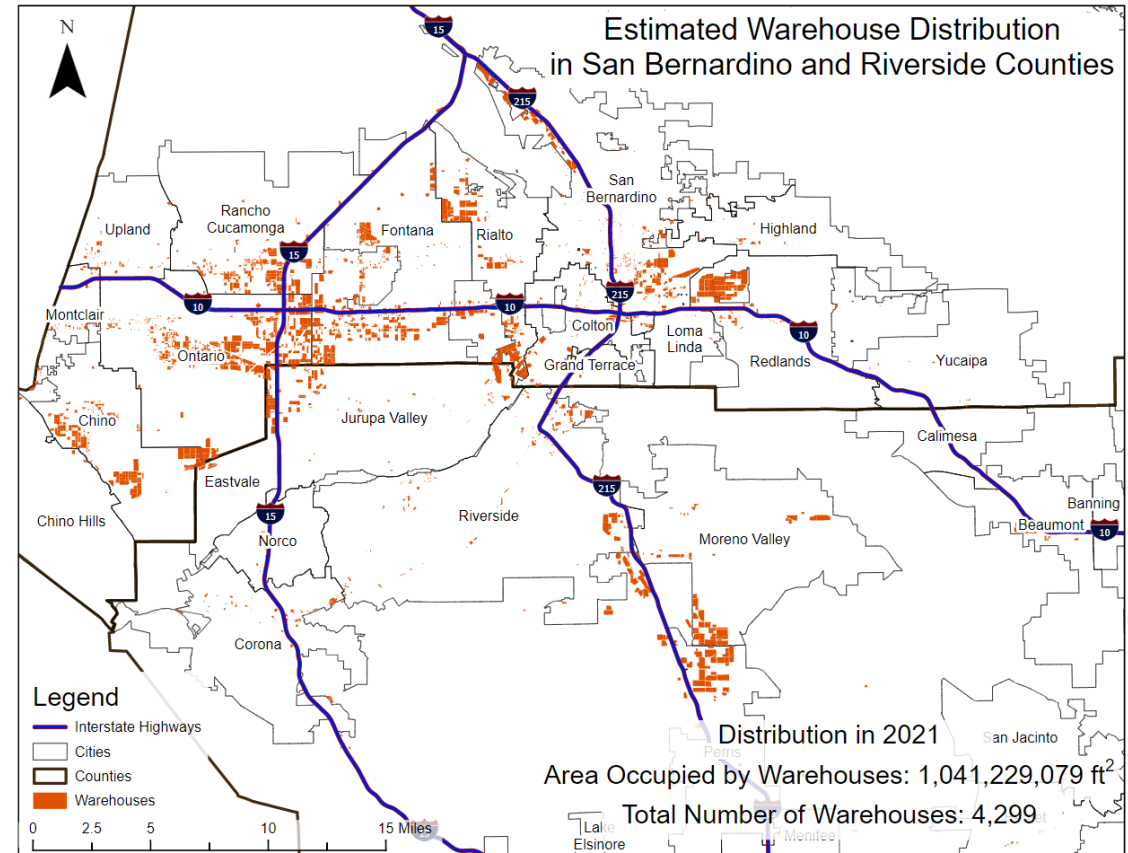

Close to residential neighborhoods



There are more than 3,000 warehouses in San Bernardino County and nearly a thousand more in Riverside County. (Graham Brady / Redford Conservancy at Pitzer College)



# Truck Traffic and Its Impacts

- Goods movement and associated truck traffic has local and regional impacts.
  - Traffic congestion & safety
  - Road maintenance
  - Air quality and public health
- Communities are concerned about health impacts of diesel-related air pollution.
  - Respiratory symptoms
  - Heart diseases
  - Cancer risks



Credit: [www.columbian.com](http://www.columbian.com)



# OMEGA Project

**Objective** *M*easurement/*M*onitoring/*M*itigation of **E**missions from **G**oods Movement and **I**mpacts on **A**ir Quality

**Goal:** Address emissions and air quality impacts of goods movement in Inland Southern California communities most impacted by air pollution

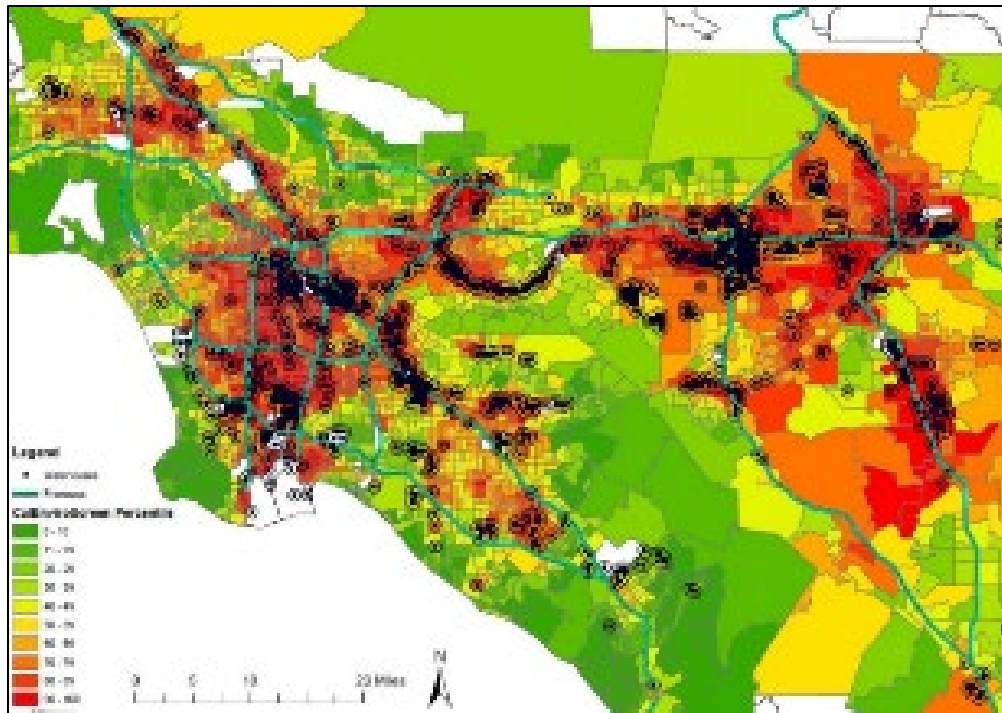

*Large warehouses are often located in disadvantaged communities*

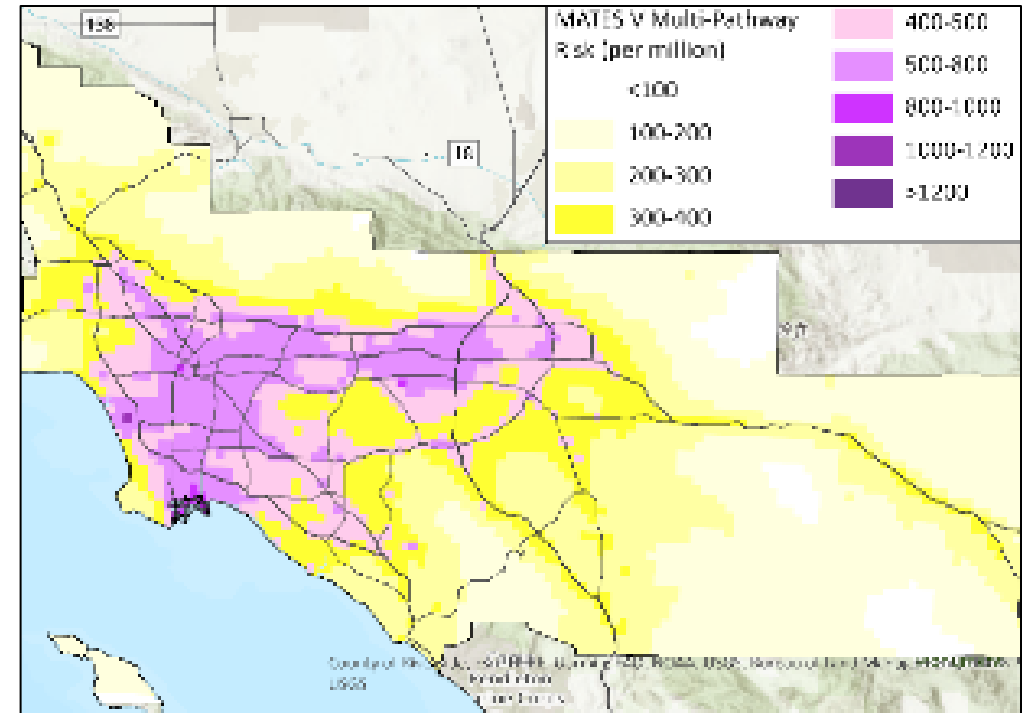

*Estimated cancer risk from MATE V study*



# OMEGA Project Components

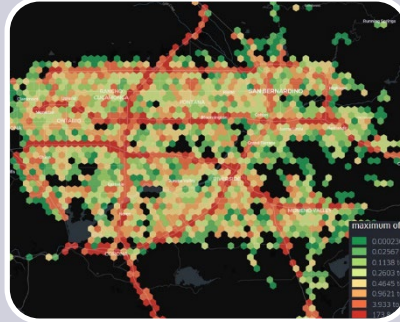

Measuring heavy-duty truck activities and emissions

Monitoring air quality in selected disadvantaged communities

Modeling emission and air quality impacts of goods movement

Developing and assessing impact mitigation strategies

Community outreach and engagement



# Refined Truck Trip Generation

- Utilize multi-layer framework that integrates:
  - SCAG's truck origin–destination trip tables
  - High-resolution (0.7 km<sup>2</sup>) fleet telematics data
  - Real-world freight facilities
- Traffic model (BEAM) simulates journey of individual trucks from one freight facility to another

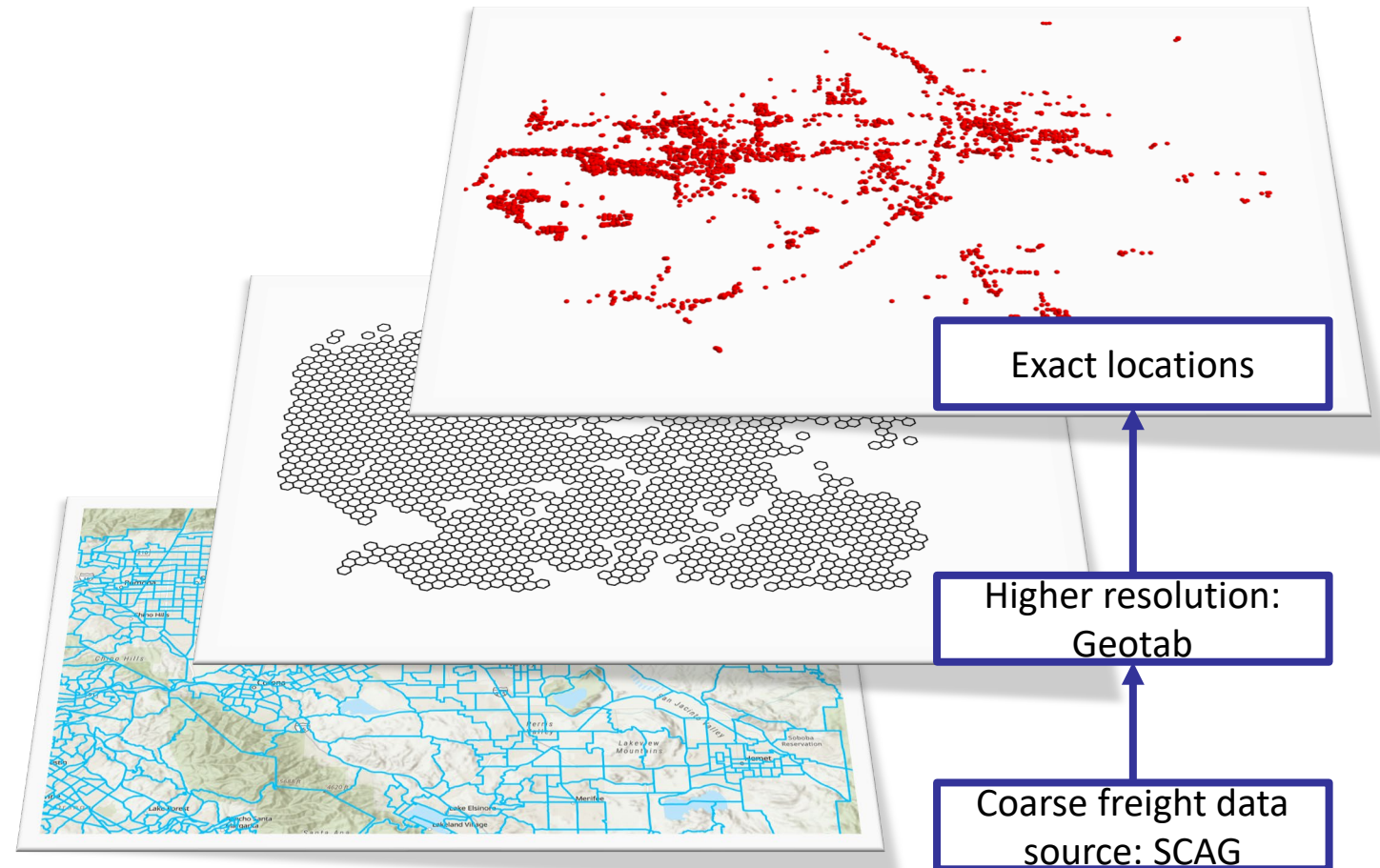



# Enhanced Regional Traffic Emission Inventory

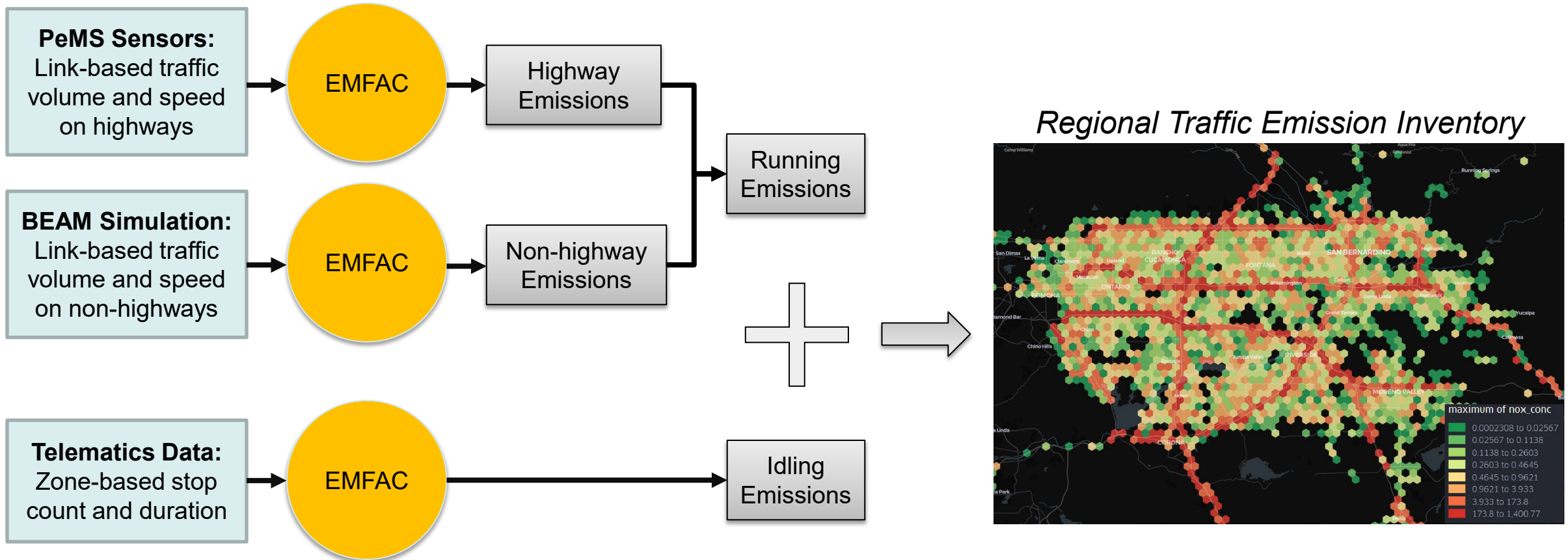



# Air Quality Modeling

- WRF-Chem v4.5.1 with 1km x 1km x 0.55km grid resolution
  - *Inputs:* Traffic emissions, other anthropogenic emissions (EPA NEI2017), biogenic emissions (MEGAN), meteorology (NCEP FNL)
  - Calibrated with data from 4 local AQ monitoring stations
  - *Outputs:* Grid-averaged pollutant concentrations

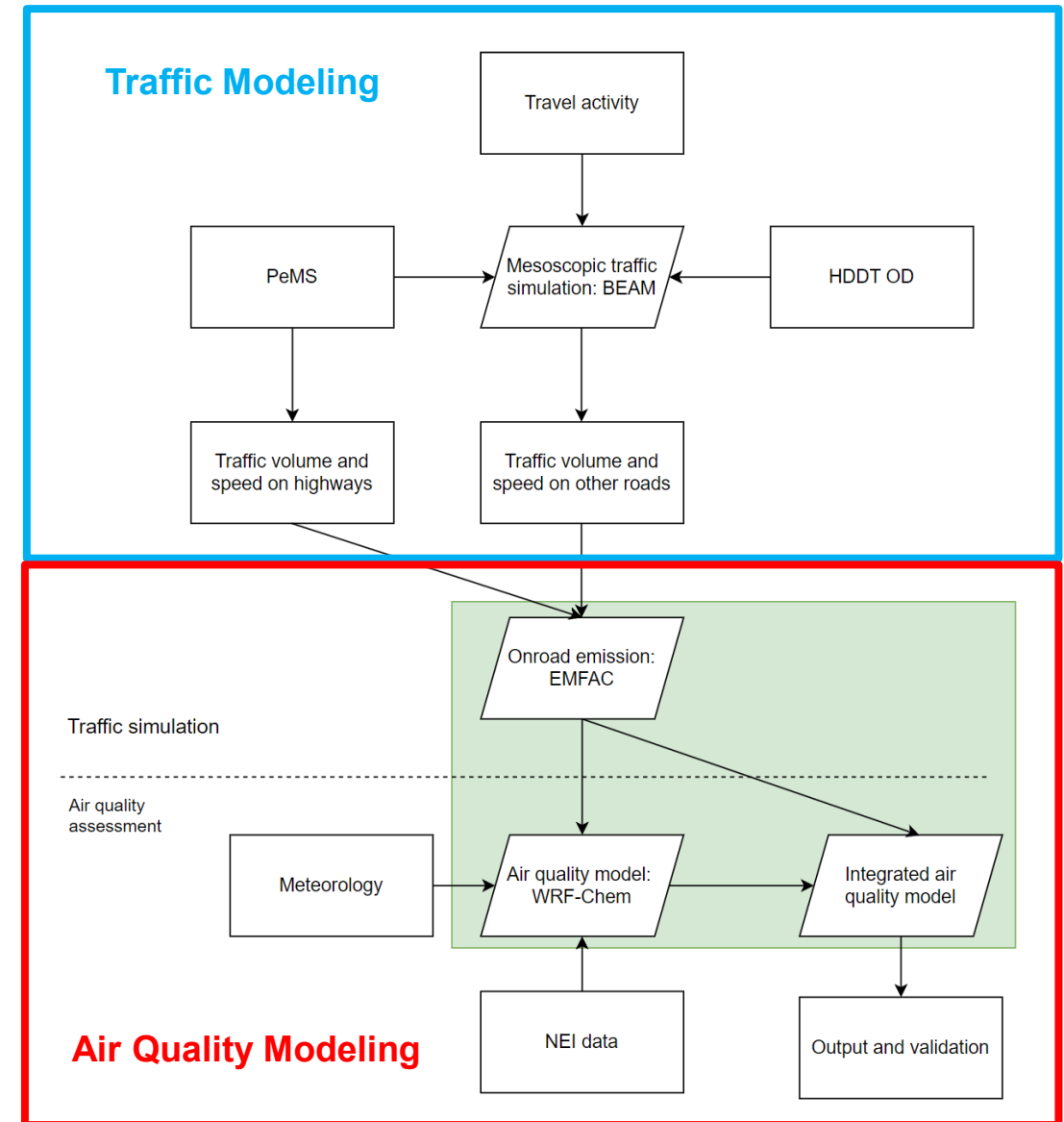



# Enhanced Air Quality Prediction

- Adjust modeled pollutant concentration based on traffic emissions around receptors and time of day
- Reduce RMSE from 0.02 ppmv to 0.006 ppmv

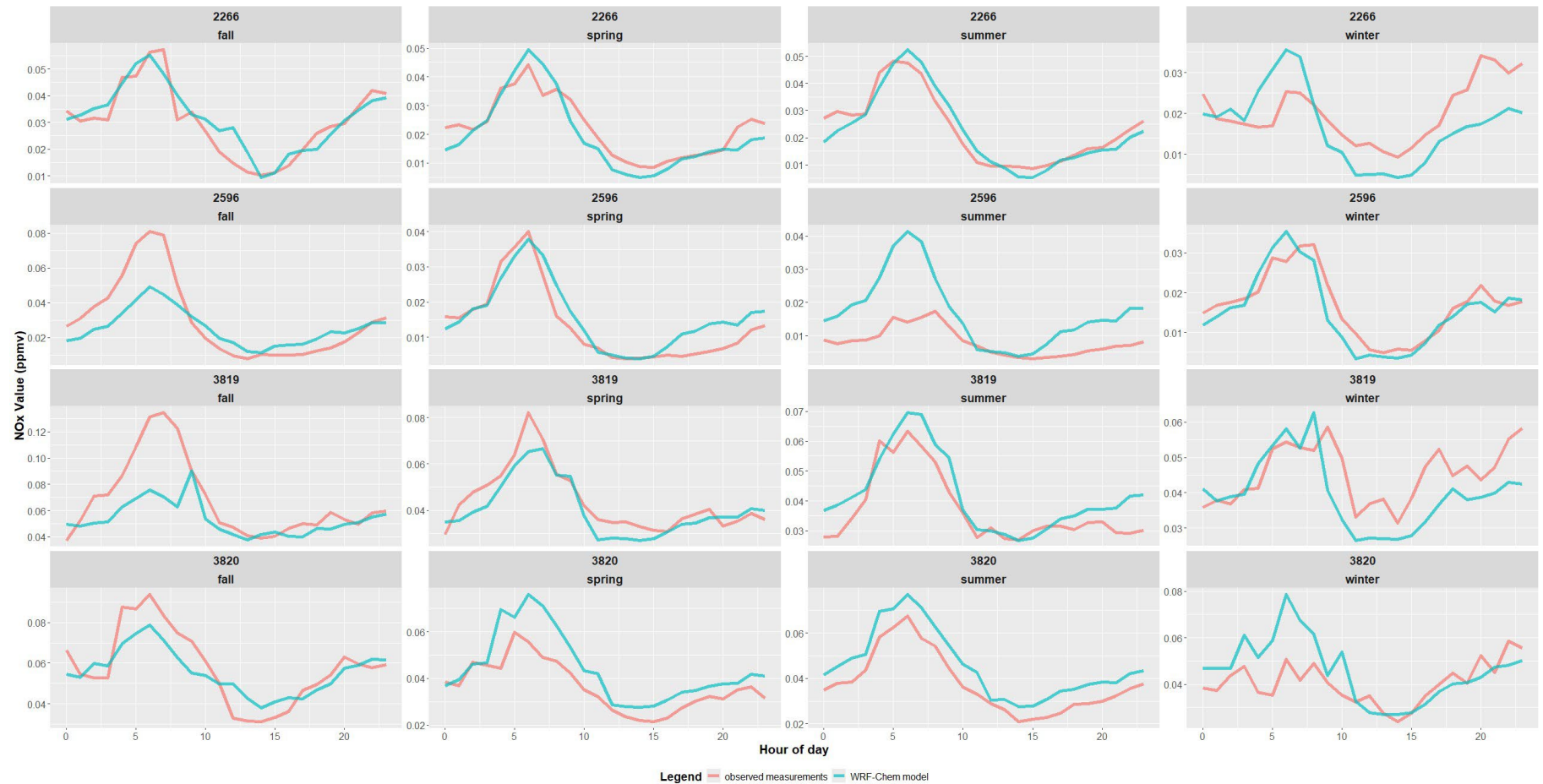



# Enhanced Air Quality Prediction Results

NOx concentration (ppmv) at 9 AM on July 10th, 2024

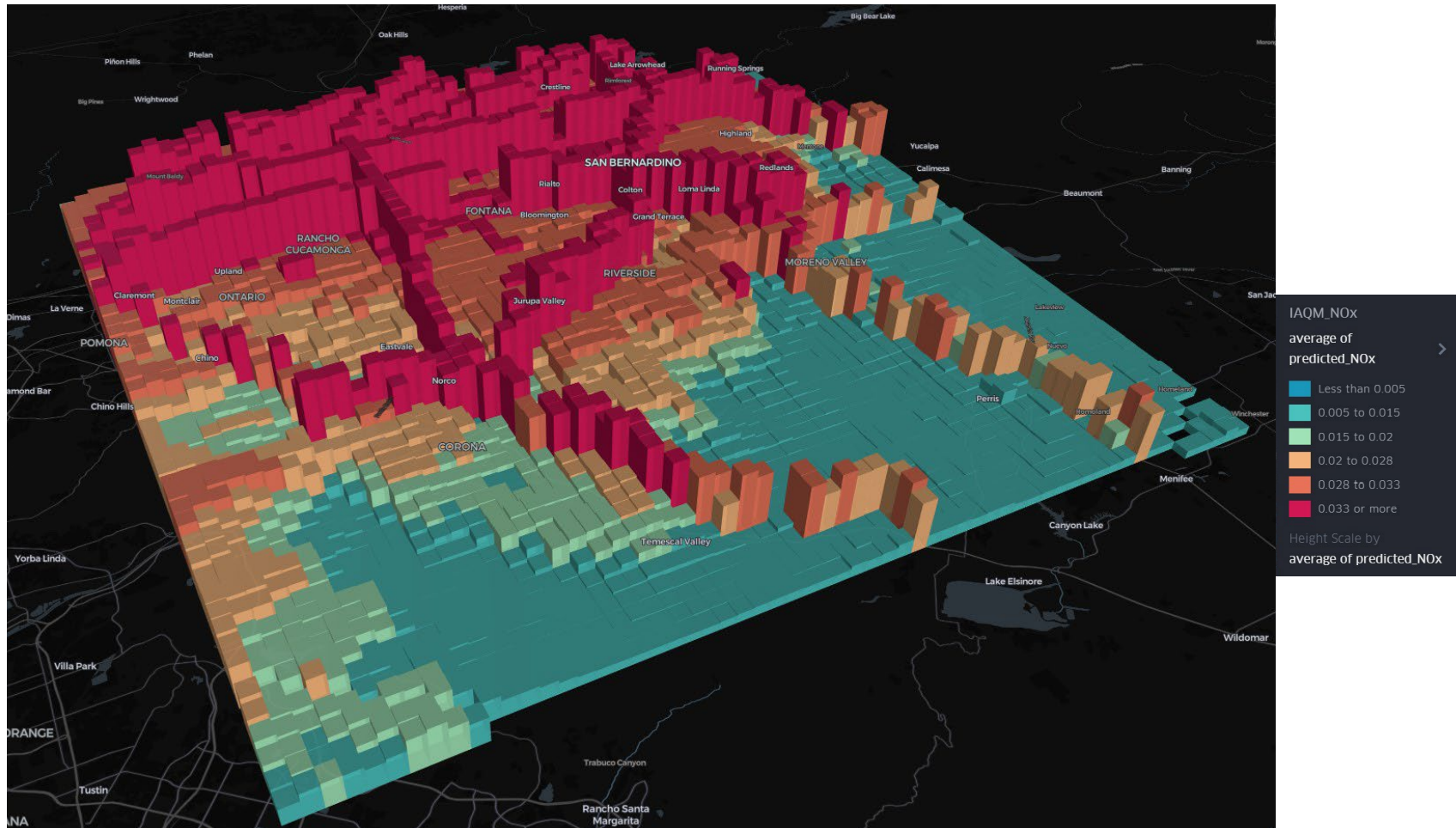



# Truck Electrification Assessment

- Electric trucks have no tailpipe emissions
  - Increasingly deployed throughout the region
- Limitations of previous studies
  - Used course truck traffic data and air dispersion model (NREL, 2023)
  - Focused on specific freight routes (Chen et al., 2023; McNeil et al., 2023)
- Scenarios in this study
  - 0% (baseline), 10%, 20%, 30% market penetration rates (MPRs) of electric trucks replacing diesel trucks





# Estimated Reductions in NOx Concentrations

- Non-near-road sites (2266, 2596):

- Larger reductions due to decreases in both running and idling emissions

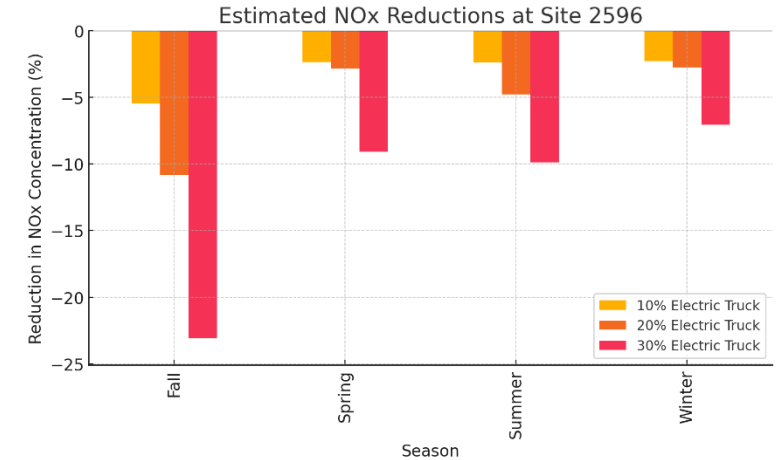
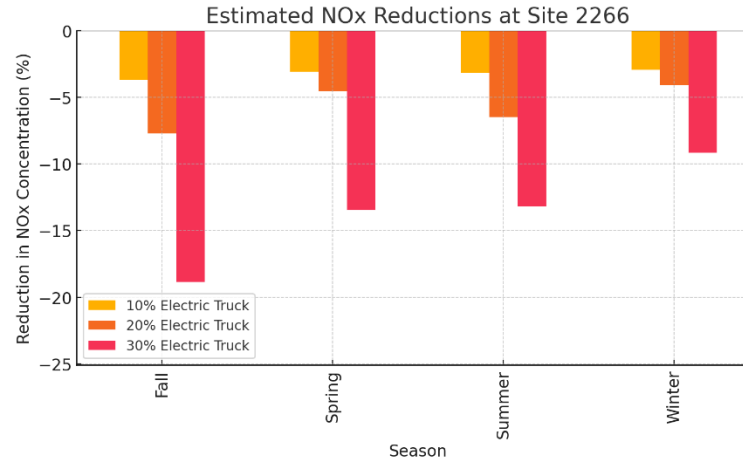

- Near-road sites (3819, 3820):

- Smaller reductions, driven mainly by running emission decreases

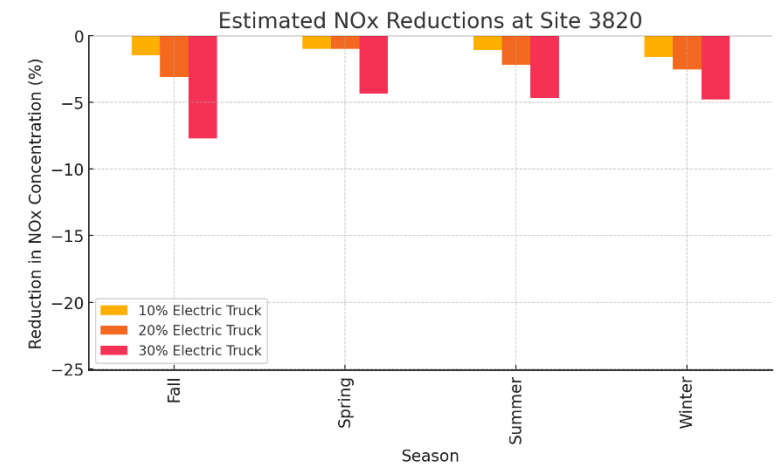
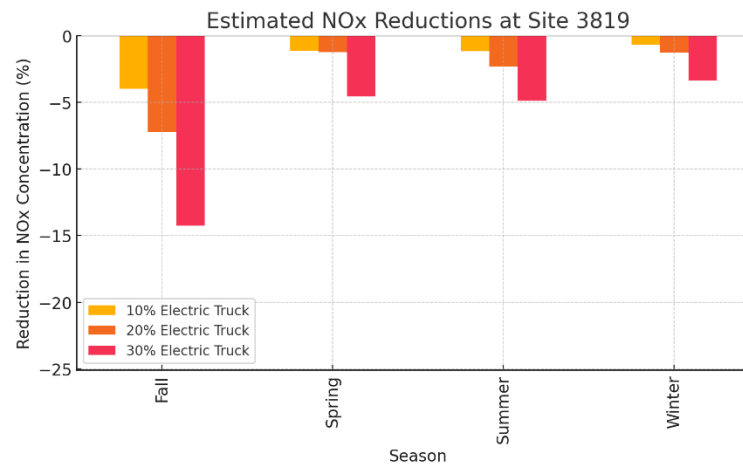



# Variations in Air Quality Benefits

- Seasonal

- *Fall*: Higher baseline NO<sub>x</sub> levels and largest absolute reductions
- *Spring/Summer*: Lower baseline NO<sub>x</sub> levels but consistent relative reductions

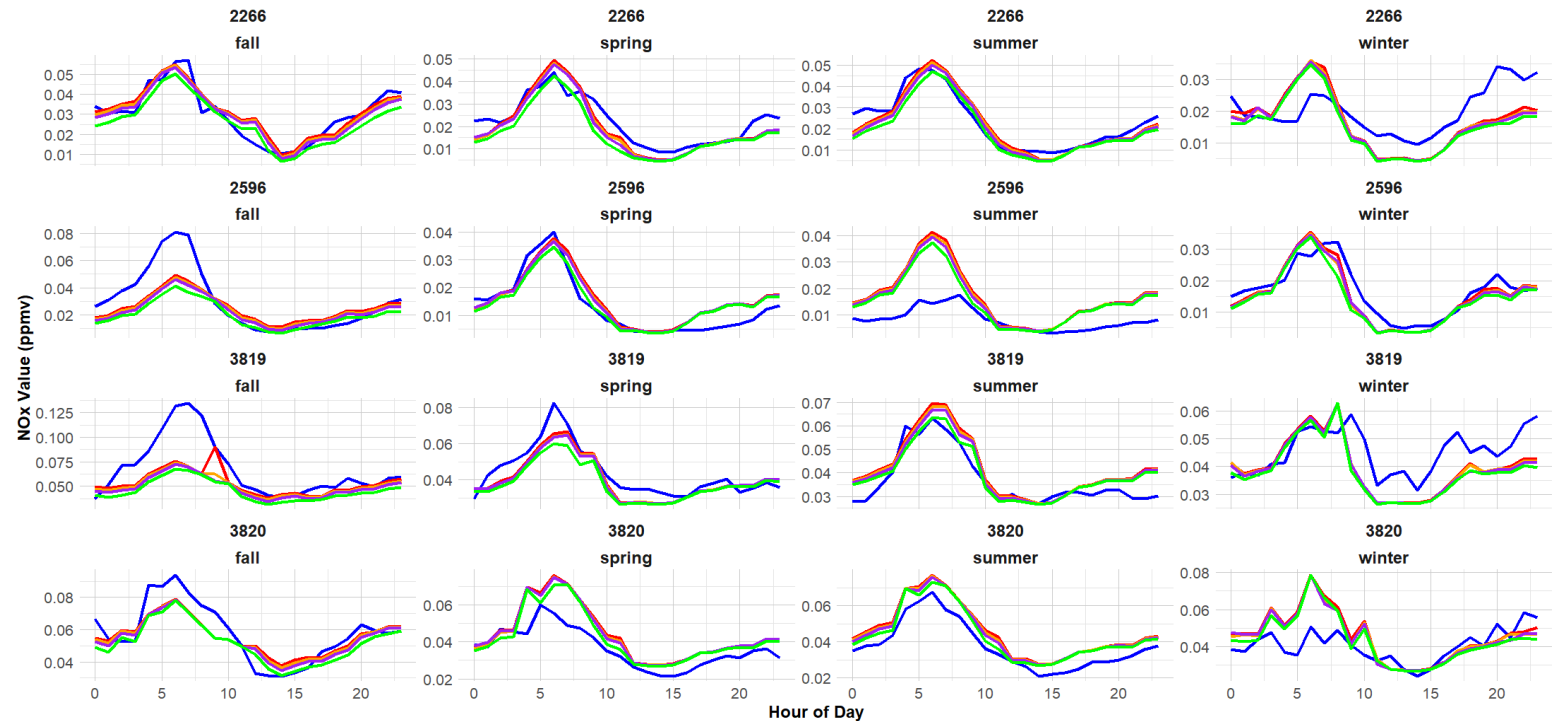

Legend - 100hdt Prediction - 70hdt Prediction - 80hdt Prediction - 90hdt Prediction - Observed

- Diurnal

- Larger reductions during morning & afternoon peaks



# Conclusions

- OMEGA program was initiated to address emissions and air quality impacts of goods movement.
  - Started with Inland Southern California and hope to expand in the future
  - Enhanced freight activity, emissions, and air quality impact modeling tool was developed
- Truck electrification can lead to measurable air quality improvements.
  - ~10% reduction in average NO<sub>x</sub> concentration with 30% electric truck market penetration
  - Larger reductions in communities due to decreases in both running and idling emissions
- Enhanced modeling tool can support the assessment of various AQ programs at the community/neighborhood level.
  - Clean fuel investments, indirect source rule, etc.



# Acknowledgements

- **Funding**
  - Automobile Emissions Research and Technology Fund administered by the California Attorney General's Office
  - South Coast Management District
  - Center for Healthy and Efficient Mobility
- **Contributors**
  - Peng Hao, Kent Johnson, Thomas Durbin, Zisimos Toumasatos, William Porter, Yejia Liao, Lynne Xu as well as many other colleagues and students UCR
  - Jennifer Lentz and Diana Alvarado of Coalition for Clean Air
- **Collaborators**
  - Coalition for Clean Air
  - California Air Resources Board
  - California Department of Transportation
  - Dependable Highway Express
  - UPS
  - Air quality sensor host sites
  - Emisense
  - HEAT
  - Indrio Technologies

# UCR A Summary Status of HD Vehicle Emissions

2025 South Coast Air Quality Management District Retreat  
September 17, 2025

**Kent Johnson**

George Scora, Zisimos Toumasatos, Georgios Karavalakis, Thomas D. Durbin, and Graduate Student Grace Johnson  
CE-CERT



# Status of the Mobile Fleet NOx Inventory, EMFAC 2021

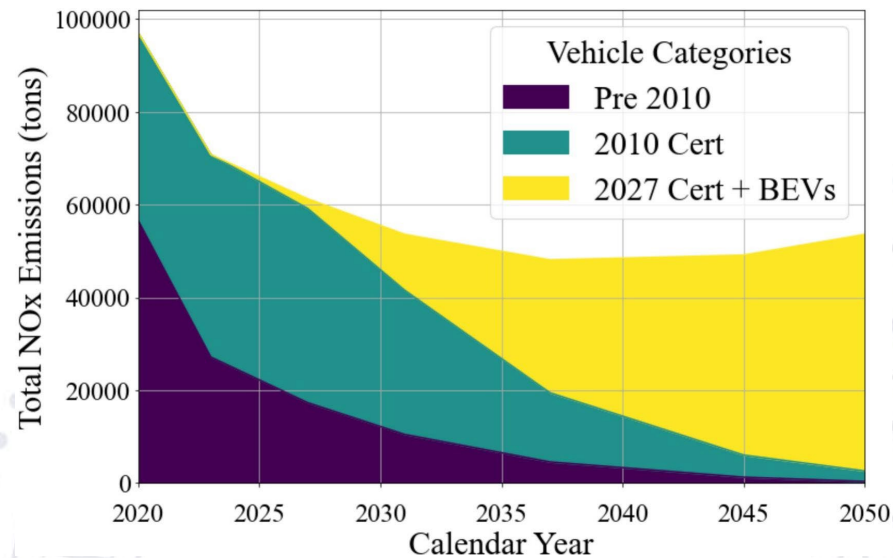
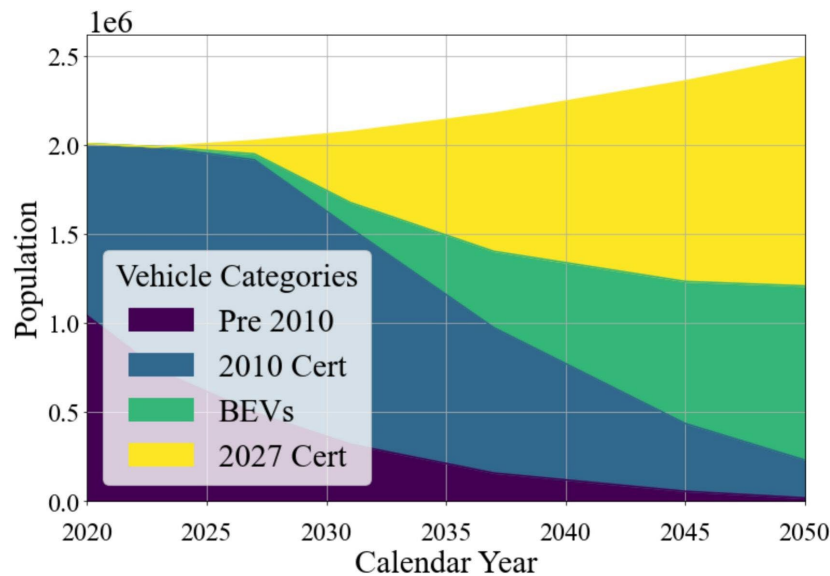

**Table 3**

EMFAC2021 specific NOx default data.

Model year category	NOx (g/mile)
Pre 2010	4.3
2010–2017	1.9
2017–2020	1.0
2021–2026	0.77
2027–2035	0.48
2035–2050	0.44



The impacts of improving heavy-duty internal combustion engine technology on reducing NOx emissions inventories going into the future

Troy Hurren<sup>a,b</sup>, Thomas D. Durbin<sup>a,b</sup>, Kent C. Johnson<sup>a,b</sup>, Georgios Karavalakis<sup>a,b,\*</sup>

<sup>a</sup>University of California, Bourns College of Engineering, Center for Environmental Research and Technology (CE-CERT), 1084 Columbia Avenue, Riverside, CA 92507, USA

<sup>b</sup>Department of Chemical and Environmental Engineering, Bourns College of Engineering, University of California, Riverside, CA 92521, USA

<https://authors.elsevier.com/c/1lB9wB8cd473l>

Thomas Durbin, Kent Johnson, Georgios Karavalakis, Zisimos Toumasatos, Grace Johnson, and Troy Hurren, The Role of OSAR in moving Towards a Sustainable Transportation Future, OSAR Conference April 2025 – Keynote

# Low NOx Combustion: Is a Positive Solution

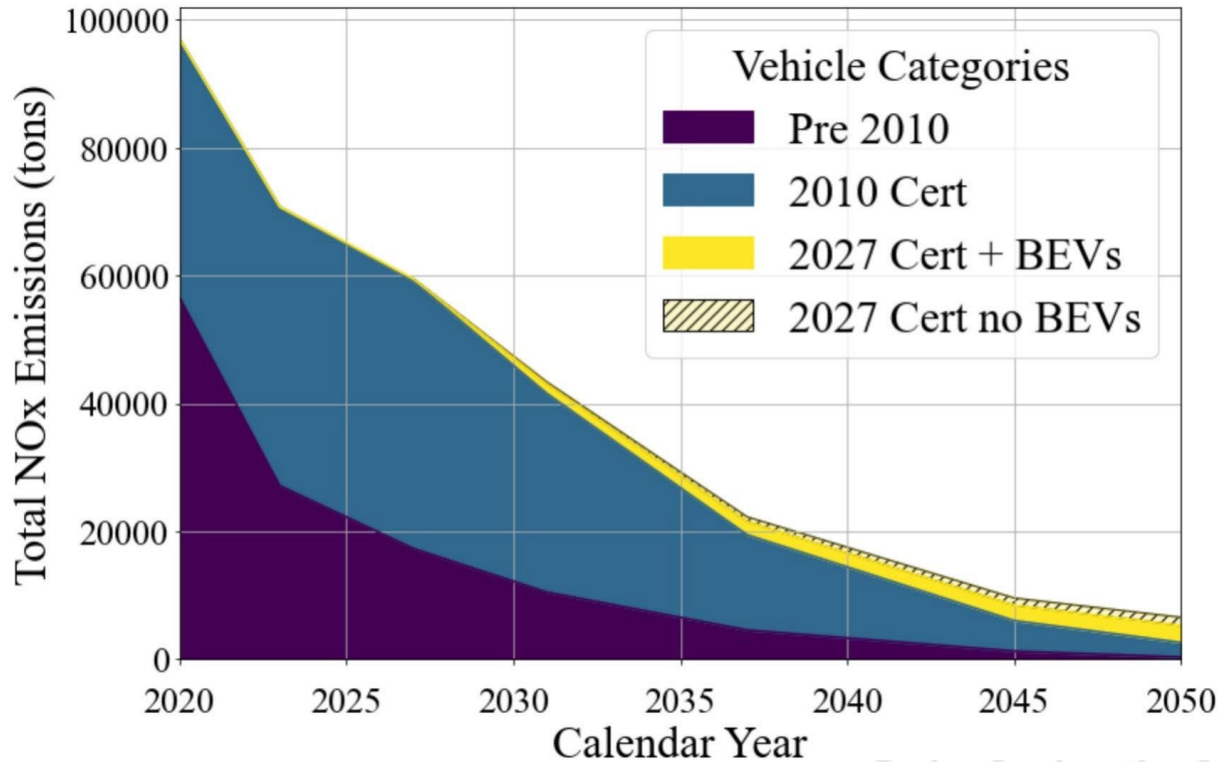

- **95% of the NOx emissions reductions** between 2025 and 2045 for heavy-duty vehicles would come from replacing older vehicles with 2027-certified low NOx vehicles running on diesel or compressed natural gas.
- To the extent that vehicle technologies could transition to completely **zero emissions** after 2027, this would **only provide an additional 5% reduction in emissions.**

# HDV Also Provided Competitive Solutions to Carbon Emissions

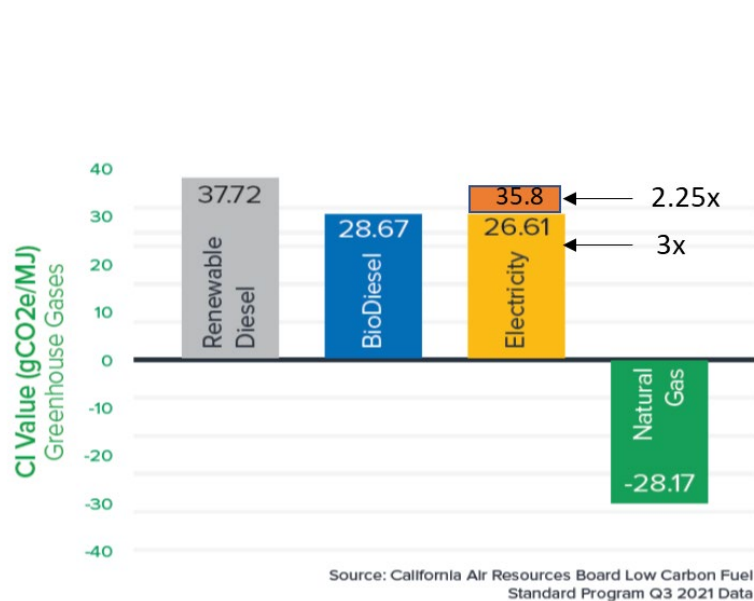

- In California, over 50% of diesel fuel is comprised of renewable fuels [Q1 2023]<sup>1</sup>, with diesel fuel for off-road equipment required to be renewable
- Renewable Diesel (RD) has ~70% (100%?) carbon intensive benefit of electricity (basis CA current grid)
- RNG has a negative CI
- Biofuels provide carbon intensity benefits equivalent to electrifying
  - 35%-50% of the Heavy-duty vehicles (HDVs) + off-road engines (OREs) in CA
  - 70%-100% of off-road equipment (since RD required for off-road in CA)
  - RNG is lower than electrifying

# So What is the Message to OEMs, Fleets, and Truckers

- We need to make sure new technology continues to work in-use now more than ever given how clean our mobile fleet can perform
- To do that we need to really monitor and evaluate its help. Can I/M do this or does it need additional effort to be effective.

## Advanced technology still to investments

- Diesel – biofuels
  - Current estimates for 2024 ~ 0.05 g/hp-hr
  - Work with a range of bio fuels
- NG
  - PM,PN emissions may need to be lower
  - NH3 emissions may need better management
  - CH4 emissions, something to think about

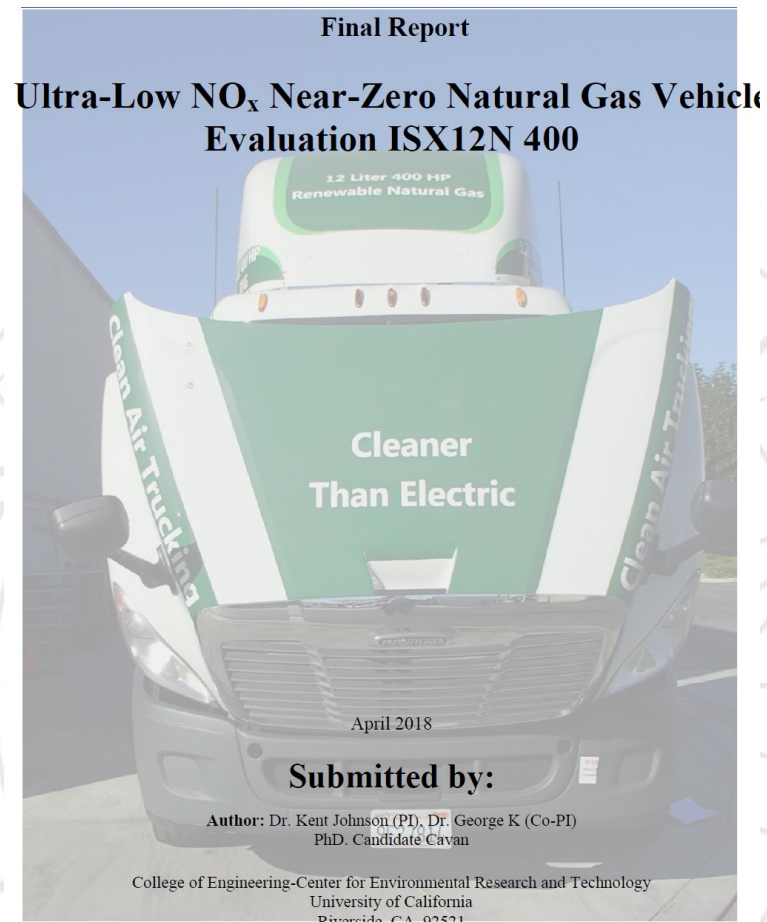

# Measurement Methods

## OSAR and RSD

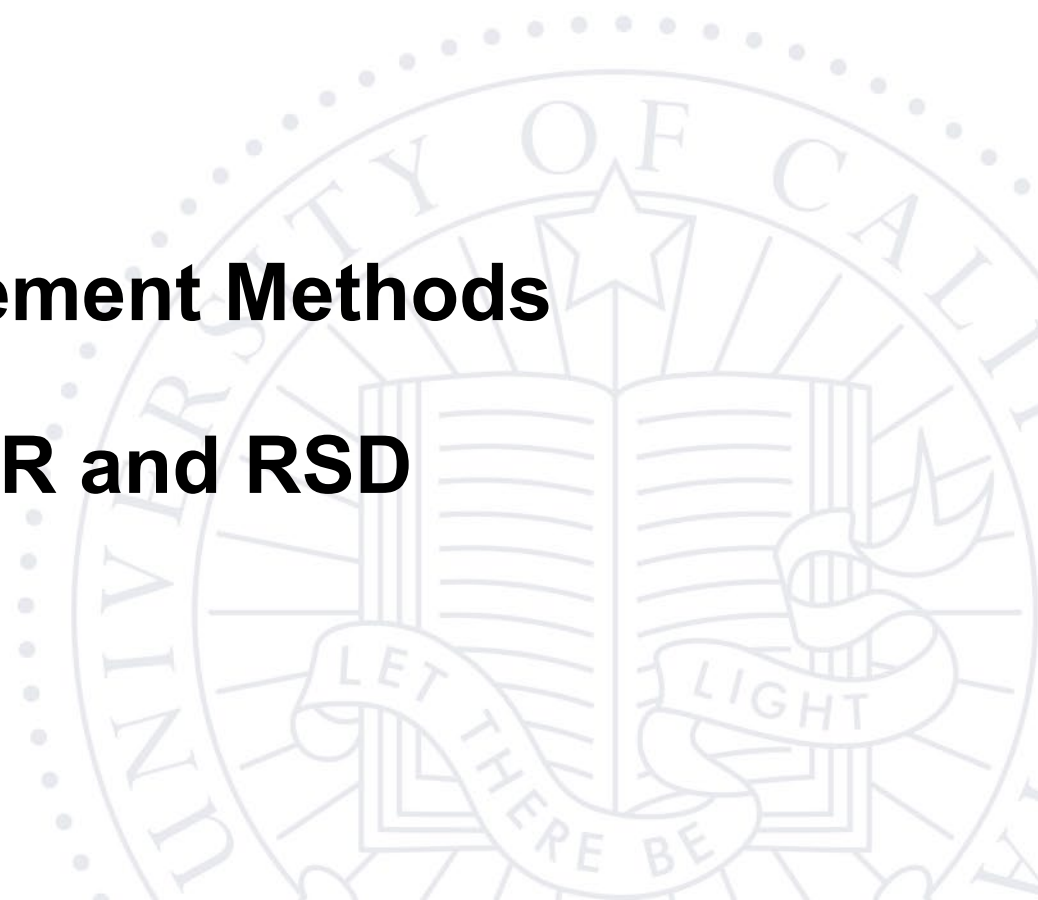

# Laboratory, In-Use Measurement, and On-Board Sensing

- Laboratory 2% margin of error (1 day of data takes weeks/months to set up)
- In-use measurement 5% (1 day of data takes 4-6 hrs to set up)
- On-board sensing 10% (1 year of data takes <1 hr to set up)

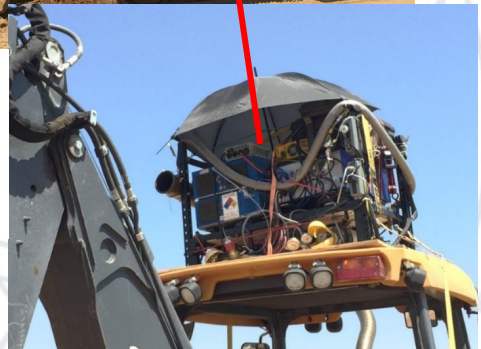
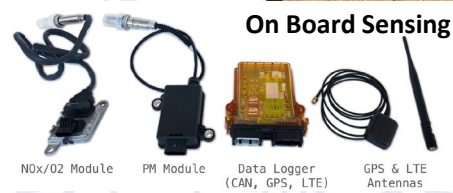
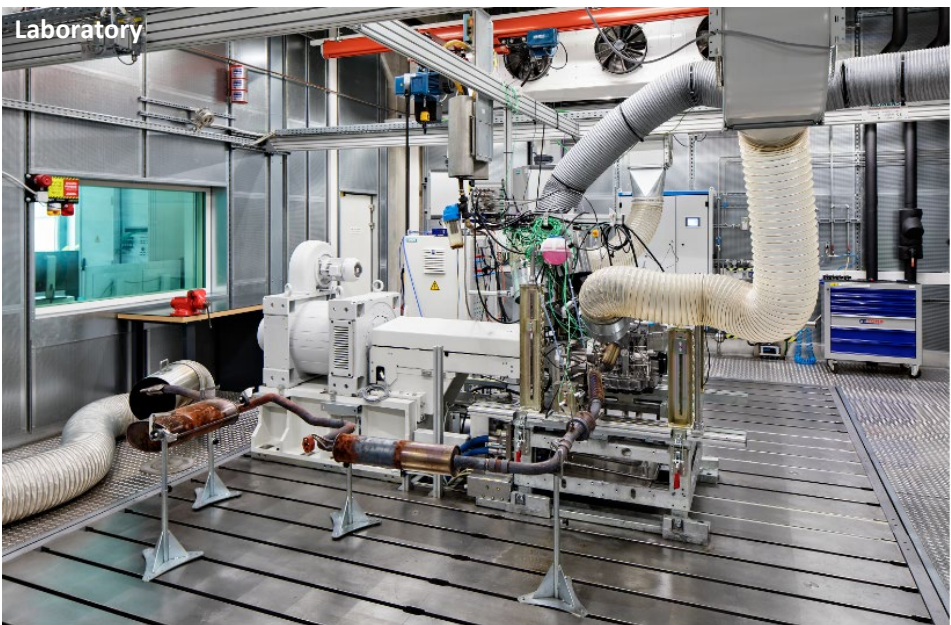

Montes, T., 2018 SAE OBDS Symposium Indianapolis, Diesel OBDS Programs ECARD Division presentation.  
 Tan, Y., Collins, J., Yoon, S., Herner, J., Henderick, P., Montes, T., Ham, W., Howard, C., Hu, S., Johnson, K., Scora, G., Sandez, D., Durbin, T., 2018. NOx Emission Estimates from the Activity Data of On-Road Heavy-Duty Diesel Vehicles. Presentation at 28th CRC Real World Emissions Workshop, Garden Grove, CA, March.  
 Yang, J., Durbin, T.D., Jiang, Y., Tange, T., Karavalakis, G., Cocker III, D.R., Johnson, K.C., 2018. A comparison of a mini-PEMS and a 1065 compliant PEMS for on-road gaseous and particulate emissions from a light duty diesel truck, Science of the Total Environment, vol. 640-641, 368-376.

# One Day of PEMS Testing Is Not Representative

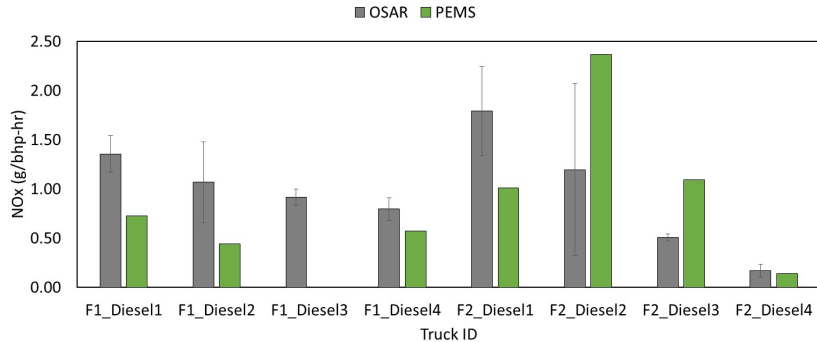

- Emissions change between days on the same vehicle
- PEMS data presented emissions measured on one day
- OSAR data showed several days of continuous monitoring results

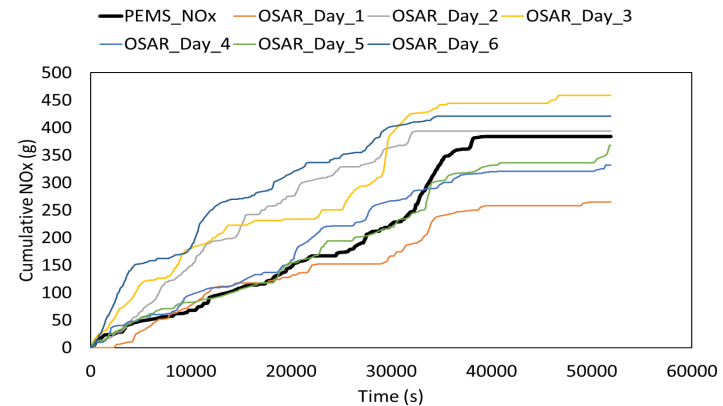
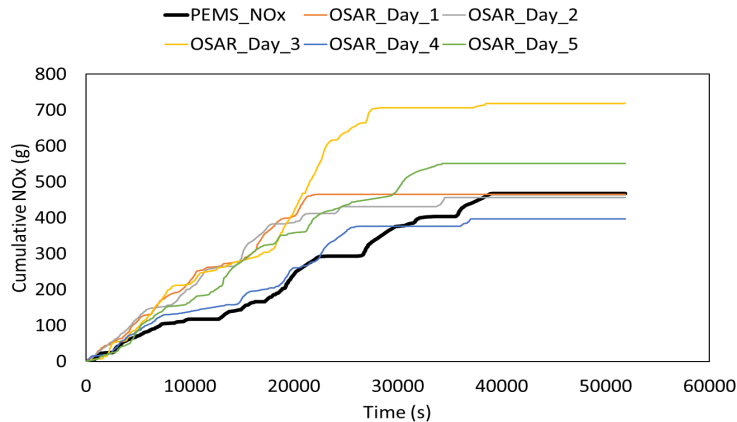

# OSAR Testing 220 HDE, On Road and Off Road 2 Mo – 1Year

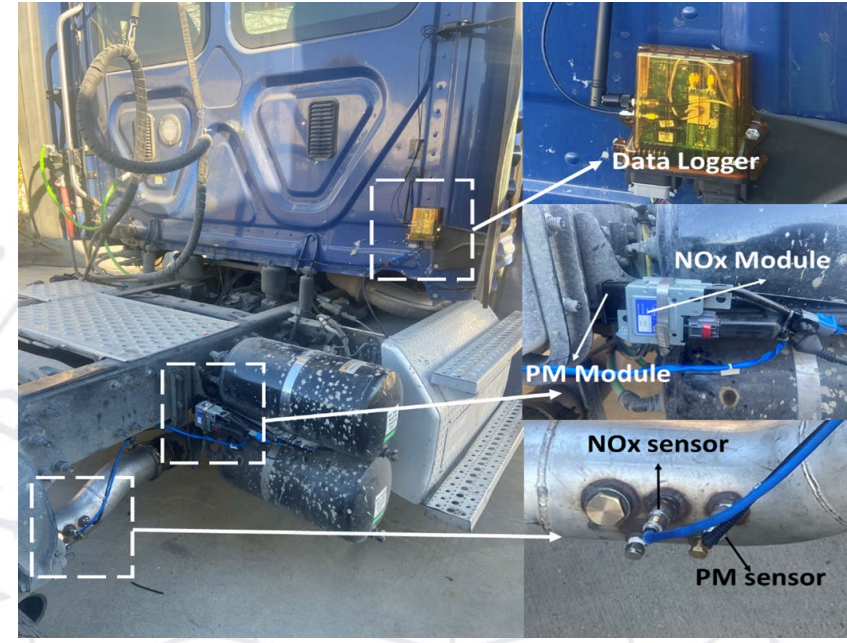
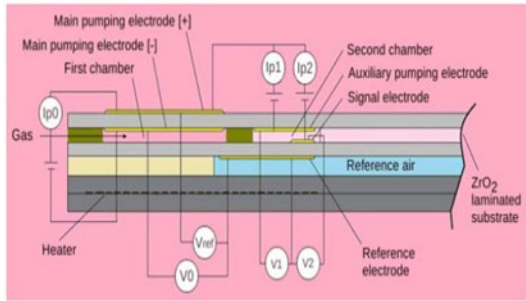
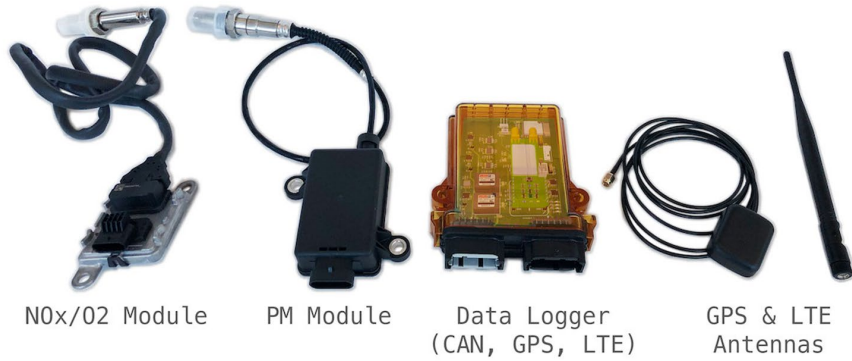

• Results in different slide

# Remote Sensing at Speed to Estimate Thousands of Trucks/Day

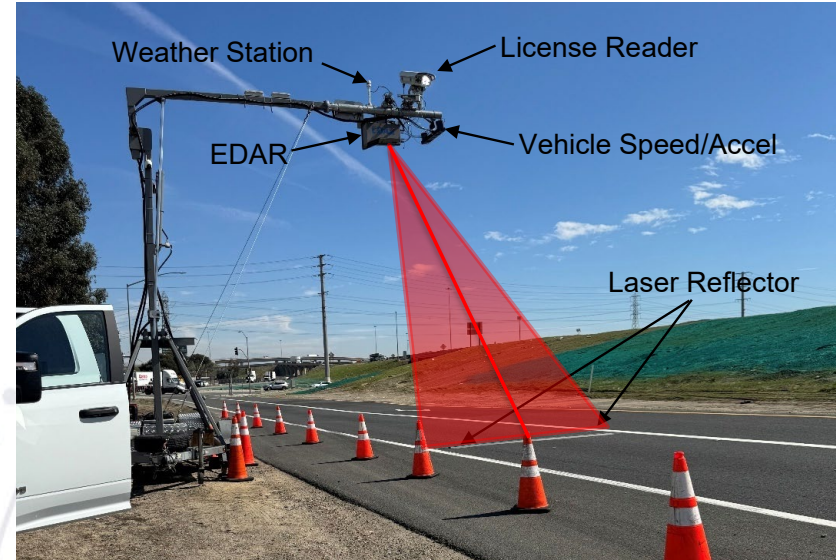

<https://www.heatremotesensing.com/>

- Two week sampling in April
  - 49,000 vehicles passed and triggered the scanner (mostly LDV)
  - 8,800 class 8 tractor trailers
  - 3,430 smaller heavy duty trucks (box trucks and short trailers)

# Remote Sensing at Speed, Estimating g/hp-hr

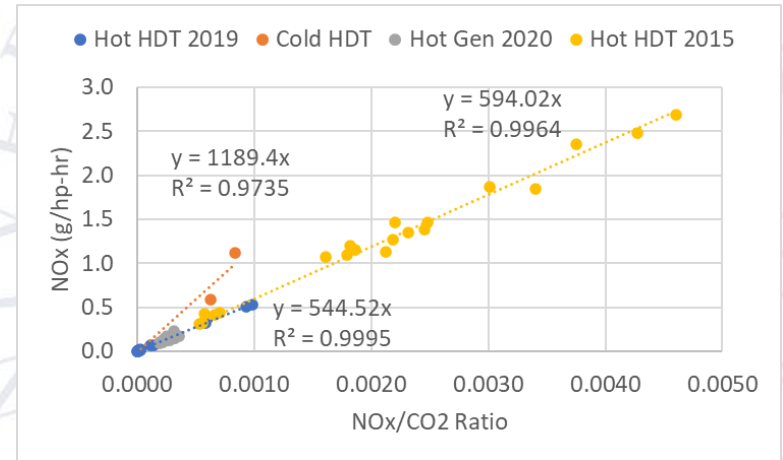
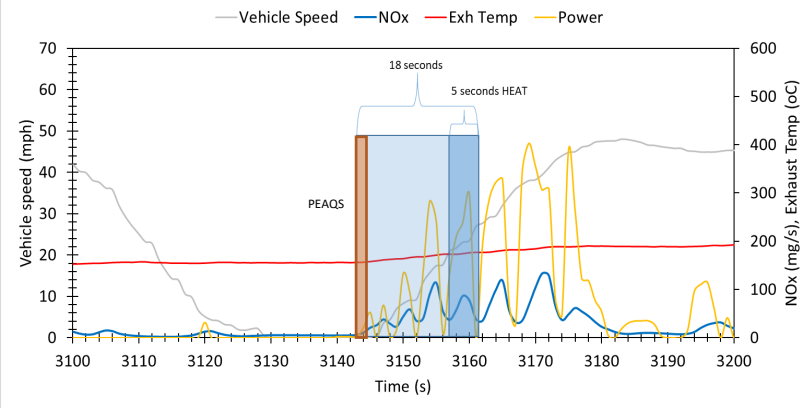
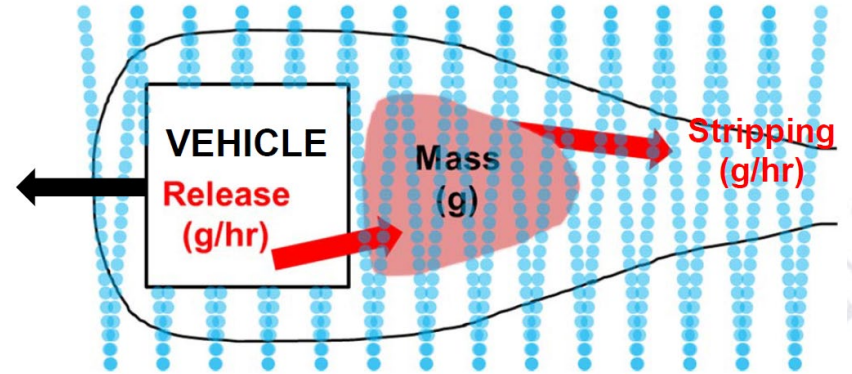

# Remote Sensing, Accel from Stop to Flag Hundreds of Trucks/Day



Example picture, not the actual inspection site

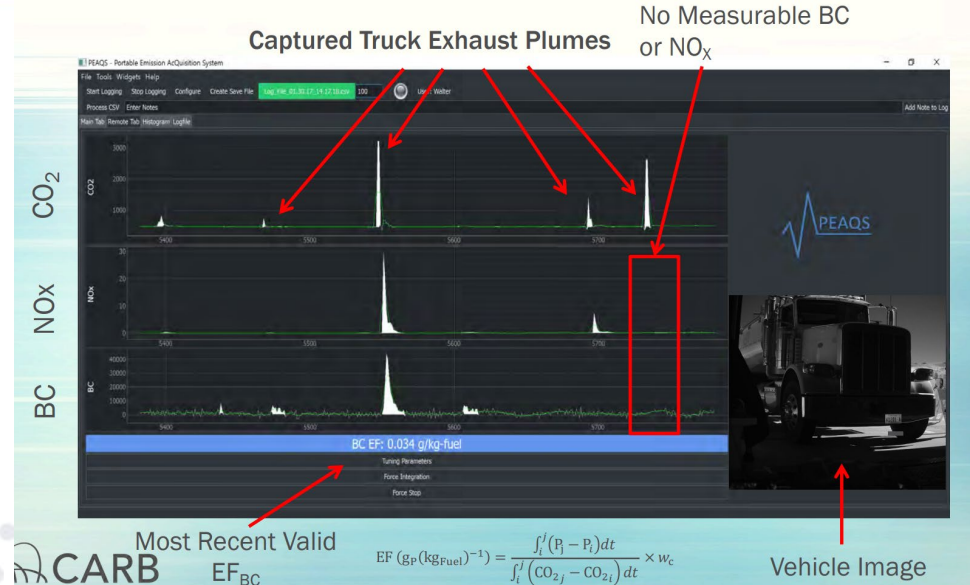

Example picture, not the actual test site result

On April 16 and 17, 2024, the PEAQS unit screened 622 heavy duty trucks. 54 pulled over for full inspection and tested for CARB regulations (8%).

- 8 Citations issued for on board diagnostic fail (OBD).
- 6 Citations issued for emission control label missing (ECL).
- 3 Citation issued for malfunction indicator light on (MIL).
- 2 Citation issued for Statewide Truck and Bus (STB).
- 2 Citation issued for excessive opacity 32 %.

$$EF (g_P (kg_{Fuel})^{-1}) = \frac{\int_i^j (P_j - P_i) dt}{\int_i^j (CO_{2j} - CO_{2i}) dt} \times w_c$$

Emission Factor Calculation

# One Day of PEMS Testing Is Not Representative

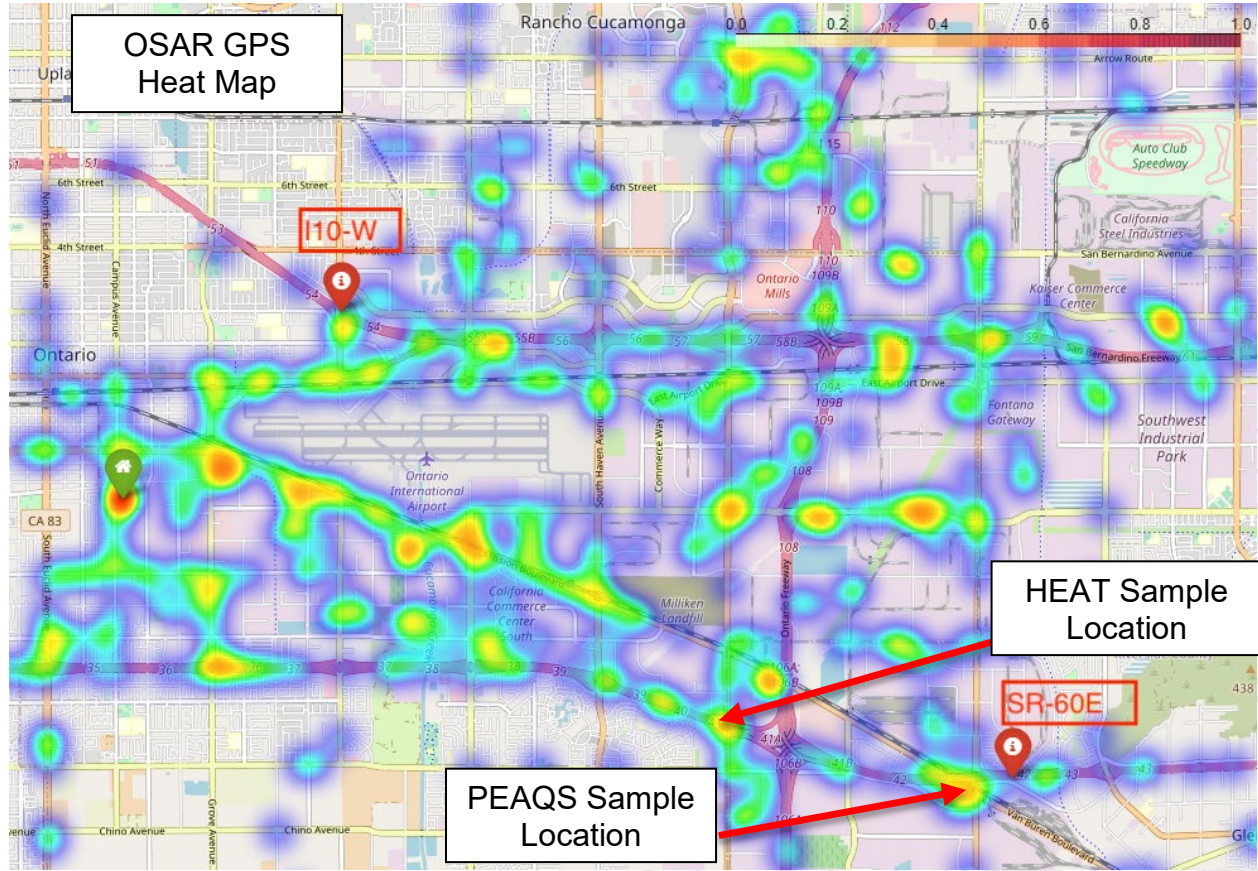

HEAT Sample Location

PEAQs Sample Location

# CARB Test Inspection sites, Referee at UC Riverside CE-CERT



Site staging area at CSU Fresno (top left)



Inspection Bay at UCR Ce-Cert (lower right)



# **OSAR, PEMS and RSD-HEAT**

## **NO<sub>x</sub> Emissions**

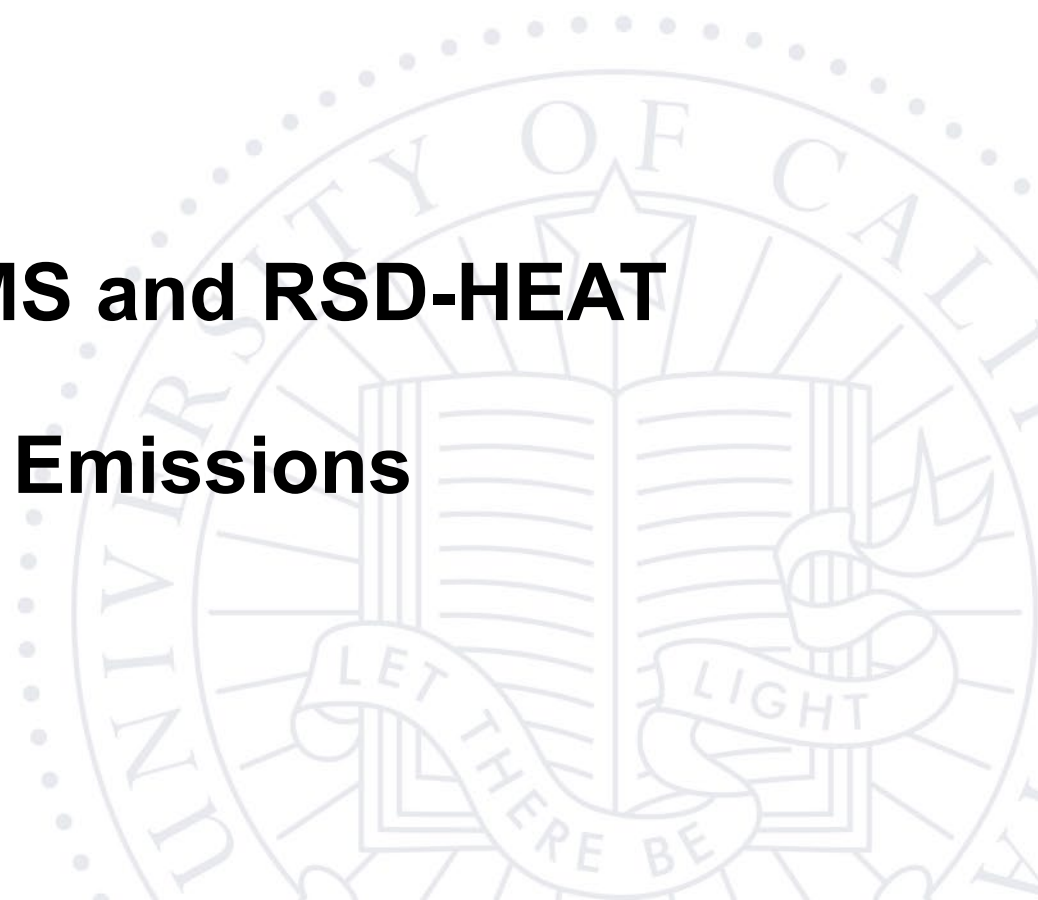

# 200 Vehicle PEMS Project NOx Emissions Summary

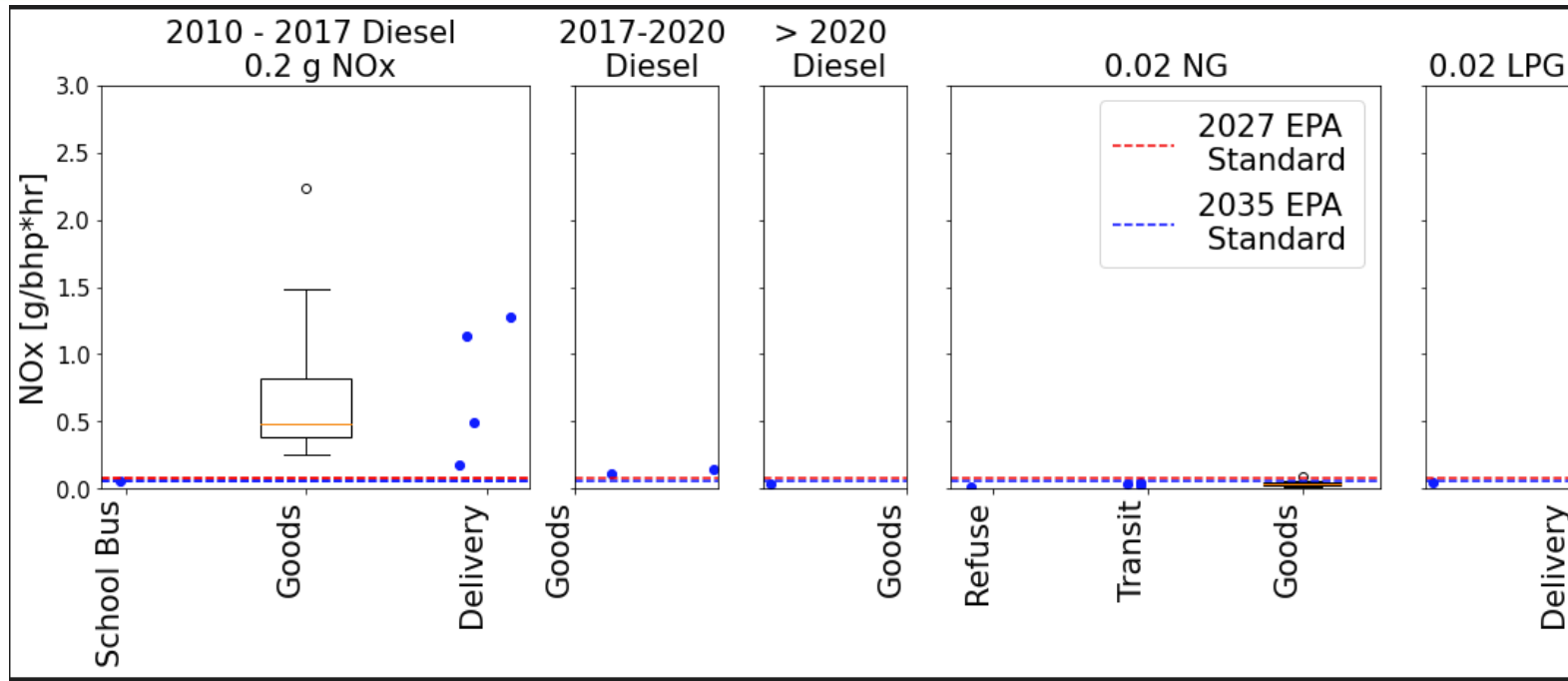

- NOx emissions

- Diesels 0.05 to 2.3 g/hp-hr
- Diesels show a reduction in NOx with MY
- NG < 0.1 and down 0.02 g/hp-hr

# OSAR NG Vehicle NOx Emissions Summary

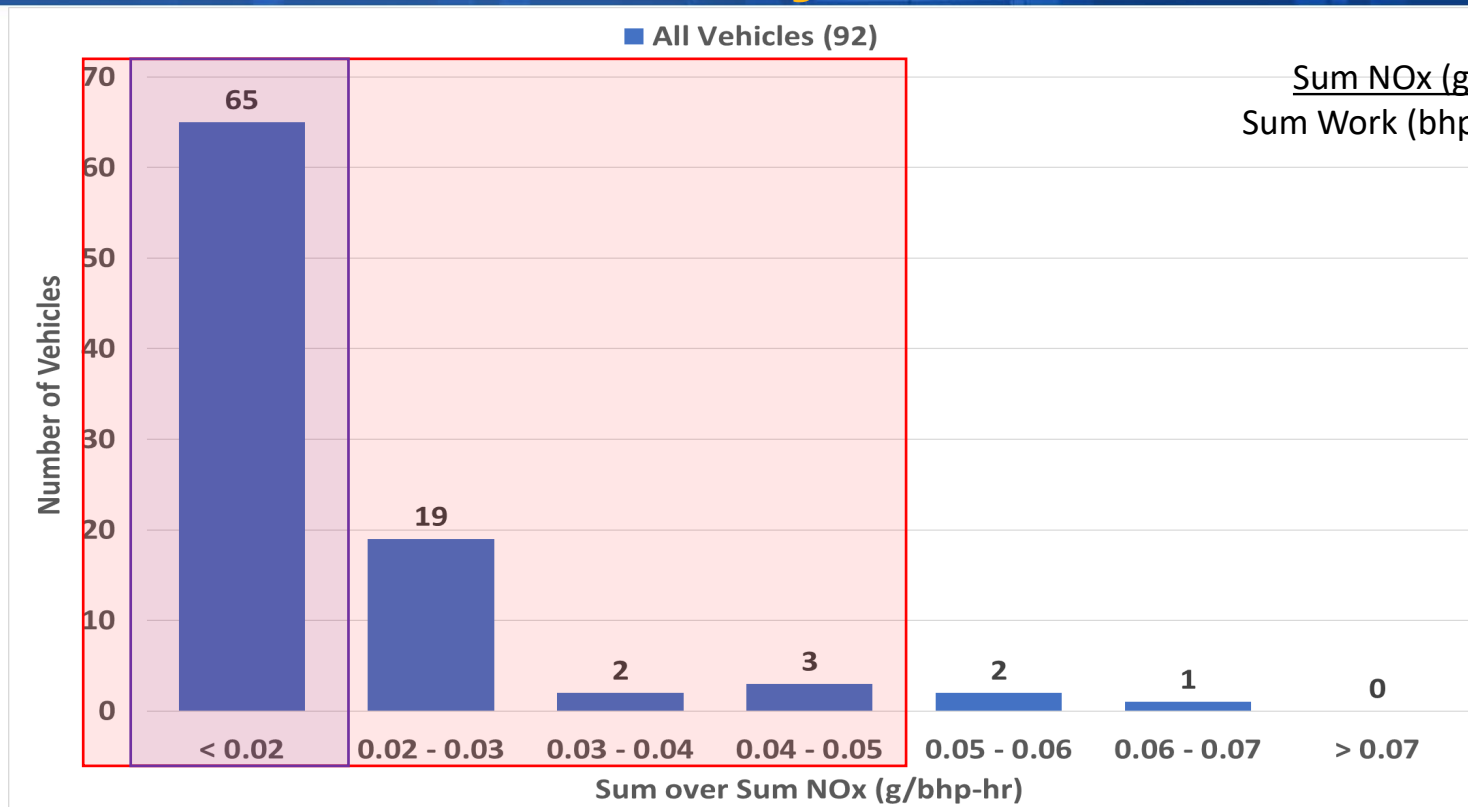

- 71% of the vehicles tested over the 2 mo interval showed emissions below 0.02
- 97% showed emissions below 0.06

# Remote Sensing at Speed, High Emitters g/hp-hr

est bsNOx From nonCold SCR Engine Correlations

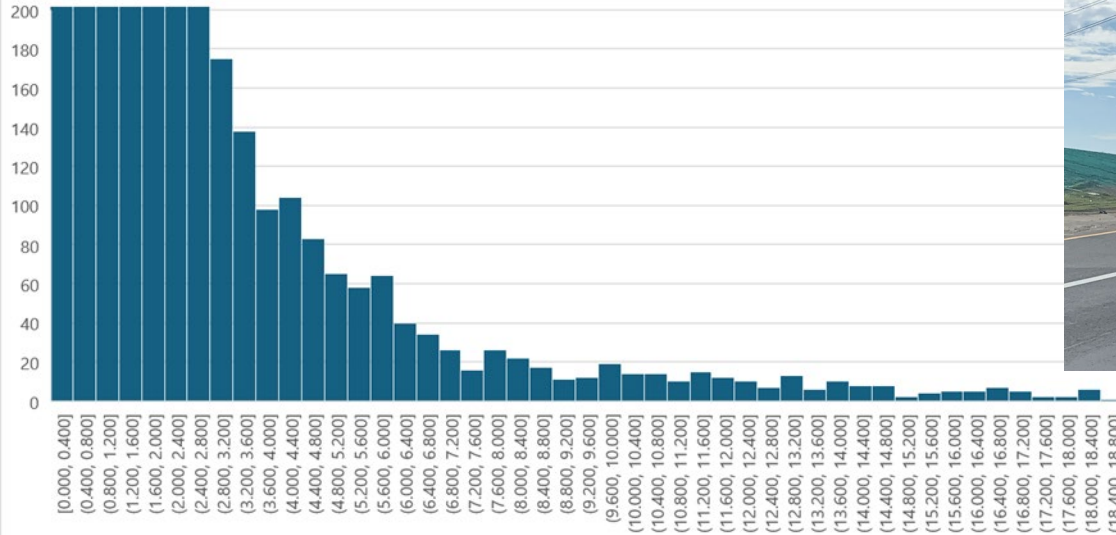

	1 g/hp-hr	3 g/hp-hr	10 g/hp-hr
Above	2741	1083	166
Ave	3.49	6.30	13.20
Stdev	3.12	3.47	2.33
% of total	32%	13%	2%

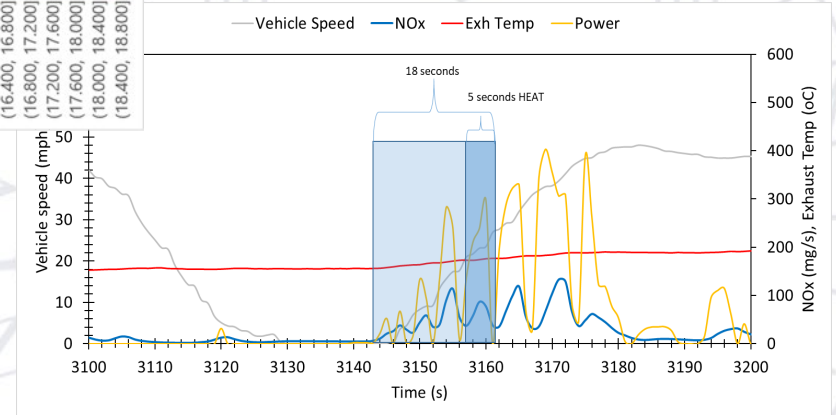

# OSAR Preliminary, Diesel Emissions Approaching NG

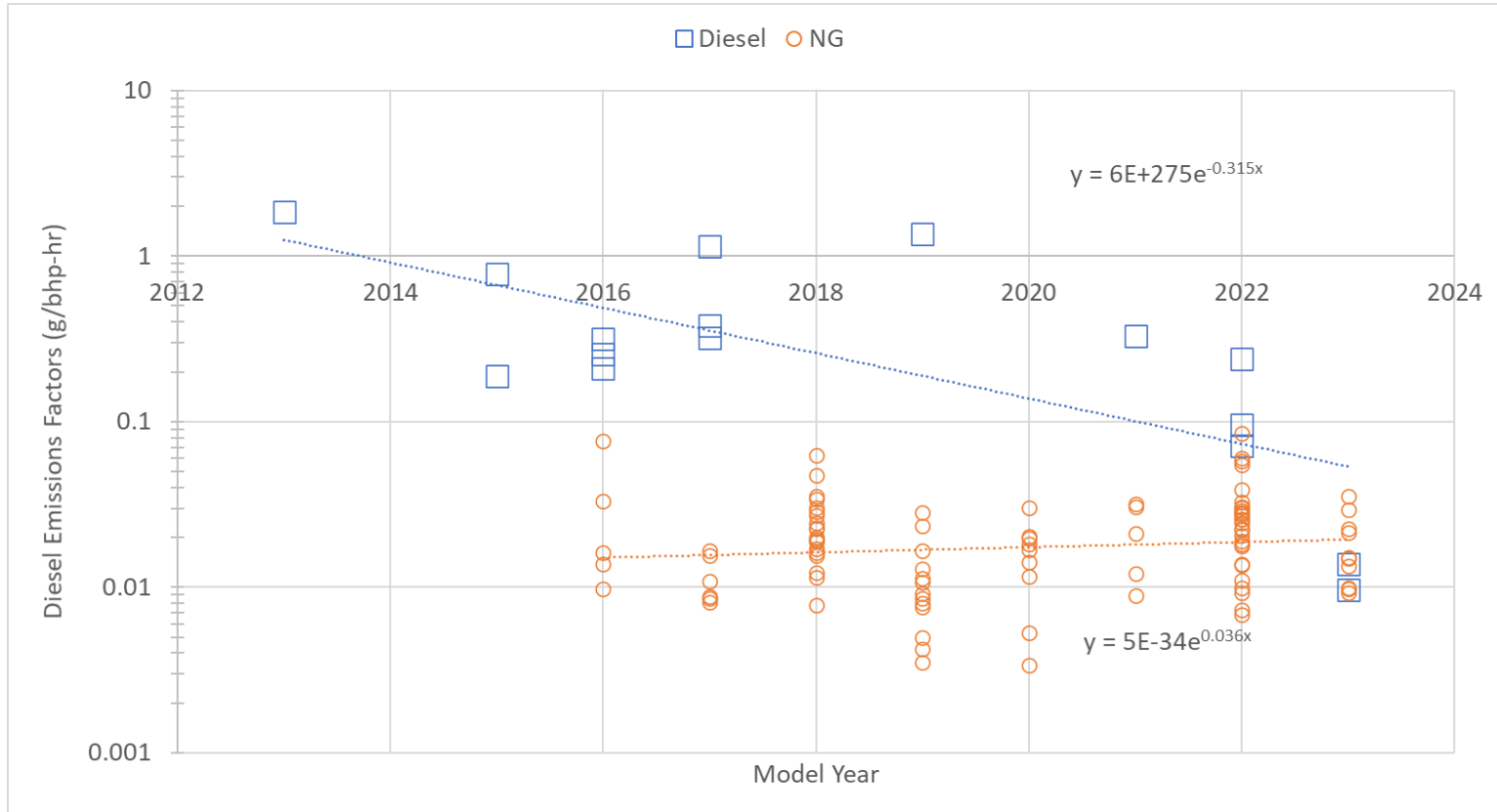

# Questions?

Future Thoughts

Consider a long term plan for evaluating I/M using HEAT. Do the high emitters get reduced and do new regulations work?

Benefit of hybridized NG (trailer option and not a full hybrid), greatly minimizing sustained rich conditions. Utilize smaller displacement engines (12L)

National policy to manage emissions and green house gases, a sustainable and economic approach.

How do we maintain emission staying low and minimize tampering without regulations



Dr. Ameya Joshi  
Founder, MobilityNotes  
[www.mobilitynotes.com](http://www.mobilitynotes.com)  
+1-(607)-542-7578

- In-use conditions have large variability in loads, distances, and other conditions that can significantly affect emissions control systems
- The in-use sensors used for this study are able to show when vehicles are or are not meeting emission standards
- 91% of the natural gas vehicles we tested fall on average under the current 1.5x 0.02 g/bhp-hr Optional Low NOx Standard
- 96% fell under the 0.058 g/bhp-hr Bin 2 Federal Off-Cycle Level

# California Hydrogen Systems Analysis

SCAQMD Clean Fuels Program Advisory Group  
September 17, 2025

**Lew Fulton**, Director, STEPS+ Energy Futures Program  
Institute of Transportation Studies, UC Davis

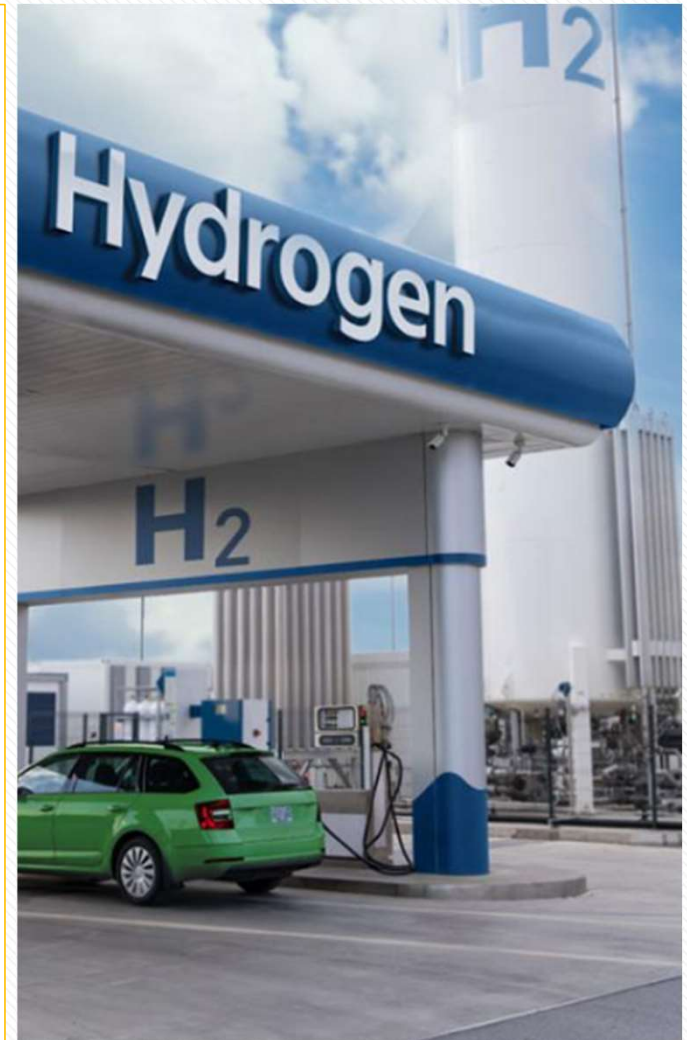

# To cover today

---

- Overview and update on CA Hydrogen Hub (ARCHES)
- UC Davis research on hydrogen systems and truck/station system planning



# ARCHES, California's Hydrogen Hub

- **ARCHES** is a public-private partnership to create a sustainable renewable, clean hydrogen (H<sub>2</sub>) market and ecosystem in California and beyond by 2030
  - <https://archesh2.org/>
- **ARCHES** goals encompass
  - Kickstart **commercial viability of H<sub>2</sub>**
    - ❑ Focus on hard-to-decarbonize sectors: **Ports, Power, HD Transportation**
    - ❑ Initiate expansion to: **Heavy Industry, Aviation, Maritime, Agriculture, and others**
  - Ramp production/offtake of renewable, clean H<sub>2</sub> from **30 tonnes per day (TPD)** to **500+ TPD**
  - Produce **measurable benefits** for California communities, with **robust monitoring**, and **strong accountability**
  - Develop a **H<sub>2</sub> workforce** for California, and a **H<sub>2</sub> workforce development model** for the nation
  - **Meet CA and National carbon neutrality goals**

# ARCHES status and key points

---

- ARCHES Signed with DOE in late July 2024, did it's official kick-off in August.
- ARCHES will have 4 phases over 6 years. Phase I is about planning with some early investment, ending in late 2025
- Phase I award includes \$20 million from DOE; State is providing up to \$100 million
- ARCHES targets about half of funding for transportation projects, half for electric power and ports
- For road transportation, ARCHES targets 5000 FC trucks, 1000 FC buses, 50 stations, by 2030
- Production to be scaled up in a coordinated way with end uses/off-takers
- Most ARCHES H2 will be from electricity that will be generated from renewables in the central valley

# ARCHES Hydrogen Flow

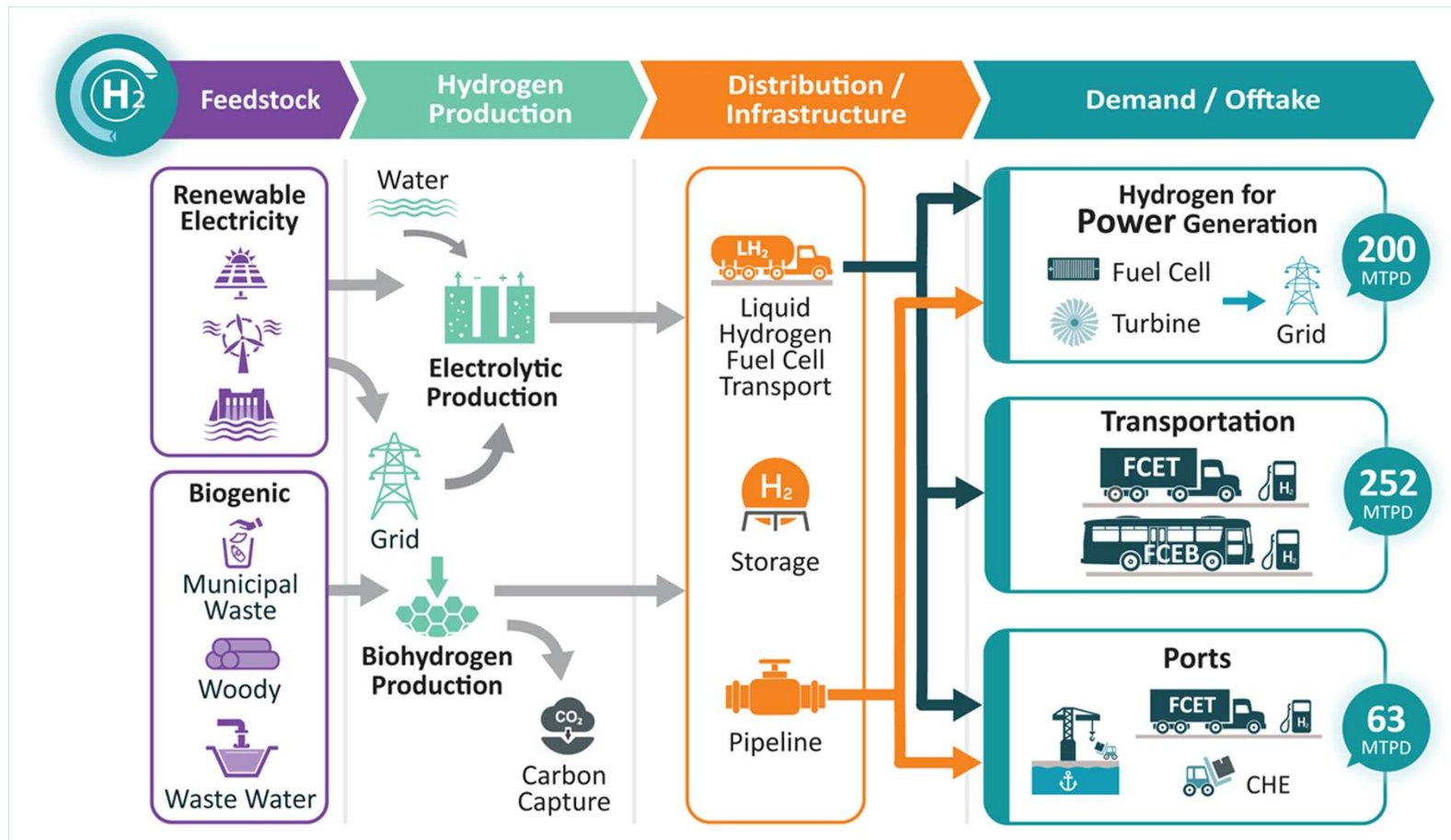

# UC Davis Energy Futures - various H2 projects

---

- Ongoing work on station economics and siting
- Ongoing work on system design and optimization
- Just published our study of [H2 system efficiency and leakage](#)
- Our H2 work feeds our transition studies and infrastructure studies, including our new [transition report](#) published last month
- Our “mapping the potential” study includes hydrogen demand projections for all major transportation modes (e.g. road, rail, shipping and air). It is in late stages and hopefully will be available as a review document in August.

# Overall H2 Findings: Key points up front...

---

- Hydrogen and fuel cell vehicle systems are **pretty expensive**, and require a large amount of up-front investment. This tends to pose considerable risk.
- **HOWEVER** – there is reason to believe that if we can **build out a reasonably large system, costs will drop** to the point where the system can be self-sustaining and an important complement to electrification.
- **HOWEVER (2)** – **we don't know how big it has to get** to achieve this point. I don't think anyone really does know this yet. It will take both scale and learning (which takes time)
- Questions for ARCHES (and audience), given **ARCHES is focusing particularly on HD trucks, 5000 by 2030:**
  - Is this enough to provide truck production scale? Open question, but it would be nice if other parts of the country also were adding such trucks, increasing scale further
  - 5000 trucks should create 200-250 tons/day demand; THIS seems like a fine quantity to support buildout of medium-large scale production plants and related infrastructure
  - It also seems like a fine approach to supporting station construction – such as 50 stations at 4 tons/day, or perhaps better yet 25 stations at 8 tons per day.
  - IS IT ENOUGH to support construction of pipelines? Open question.

# How to achieve... good timing of buildout

---

- Clearly **we will need to coordinate** the hydrogen production capacity, distribution capacity, station capacity, and #trucks and their daily hydrogen demand, to be fairly close at all times.
- **HOWEVER**, if there are lags, **they need to be DEMAND lags rather than SUPPLY lags**, since if there is a shortage of supply it's a crisis. If there is a shortage of demand there are economic shortfalls for suppliers, which can to some degree be mitigated with incentive policies.
- **HOWEVER (2)**, if production facilities or stations are operating at **low utilization rates**, this will not be sustainable for very long because any subsidies are not likely to be sufficient to make up for revenue shortfalls, and resulting prices may be high.
  - An example is that for 1 ton/day LDV stations operating at 1/3 of target utilization rate, this is on the order of 600 less kg sold than the target, which at a normal mark-up of \$3/kg is a loss of \$1800 per day or \$0.66 million per year. An obvious way to make up for this is to charge \$9/kg instead of \$3.
- A promising approach is to garner commitments to build and buy/sell various components of the system if various conditions are met. **Vehicle purchase/sales commitments** that trigger on a given supply/price of hydrogen are one approach.

## **H2 Station siting: objectives of the project**

Identify optimal station numbers, sizes, and general locations for early-phase deployment of HD fuel cell trucks in California

Develop cost and operational factors for trucks as inputs

Develop an optimization model to include:

Location allocation of cost-optimal HRS network

The growth of refueling station sizes and numbers

Amount of hydrogen demand at the refueling locations

Illustrate the HRS network spatially.

Calculate the levelized cost of HRS operation.

# How many stations for HD FC trucks? We're finding that 18 stations goes a long way

## 1000 trucks

## 5000 trucks

Hydrogen Refueling Station Siting: 1000 Trucks



Hydrogen Refueling Station Siting: 5000 Trucks

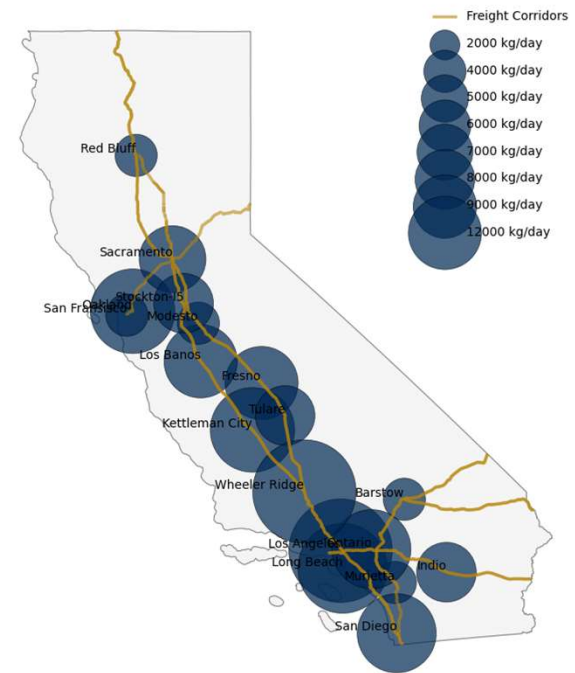

# 500 Trucks

Freight Lines by Truck Volume



Utilization (0-100%)

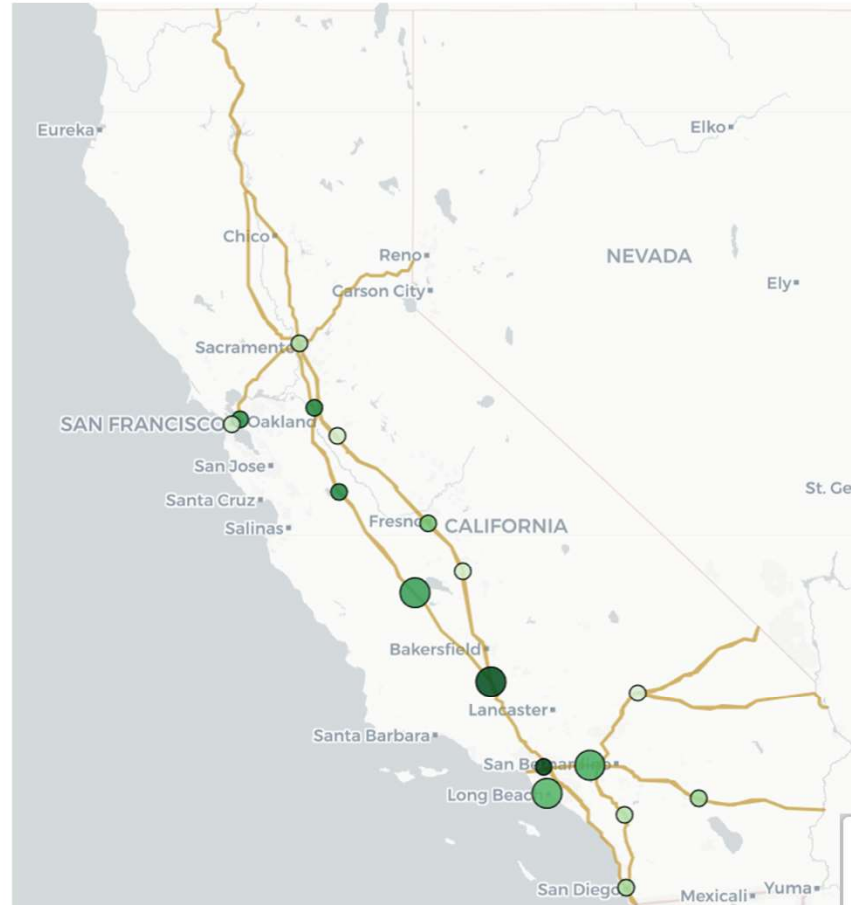

**Capacity (kg/day)**  
○ 2,000  
○ 4,000  
Sizing: circle area  $\propto$  capacity (fixed scale)

# 500 Trucks (Ports)

Freight Lines by Truck Volume



Utilization (0-100%)

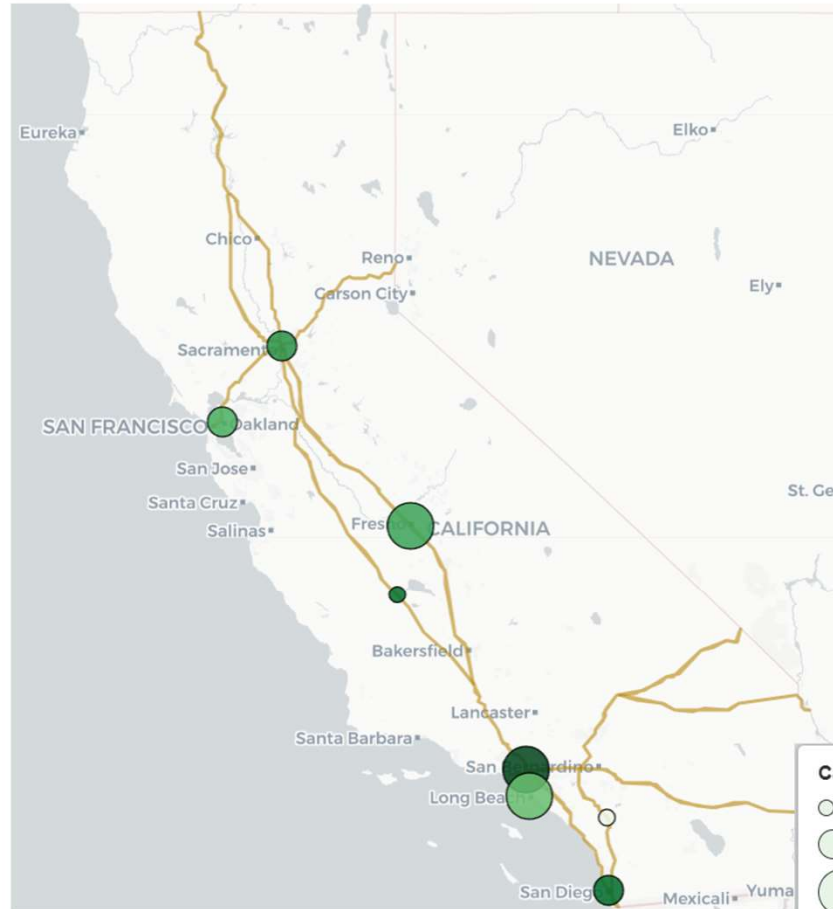

# UCD Transition scenarios

- We have a “Low Carbon Scenario (LC) and a “High Fuel Cell Scenario” (HFC), with somewhat higher sales shares for FC vehicles but same total sales of ZEVs.
- ARCHES type scenario is now the high case for HD trucks (lower figure), with sales expansion above ARCHES after 2030. How do we bring this about?

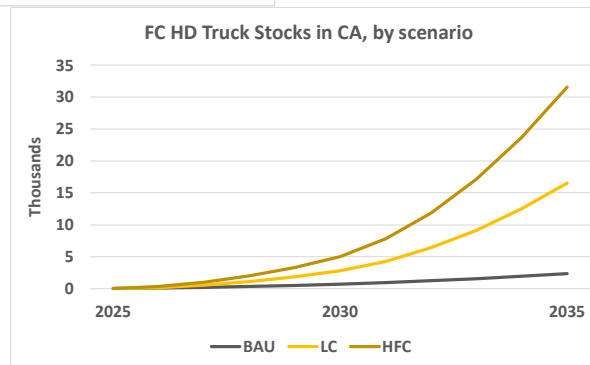
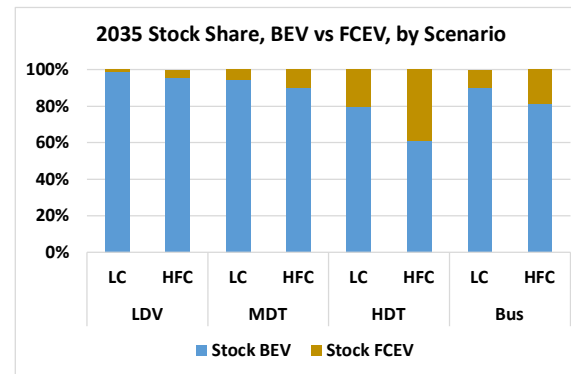
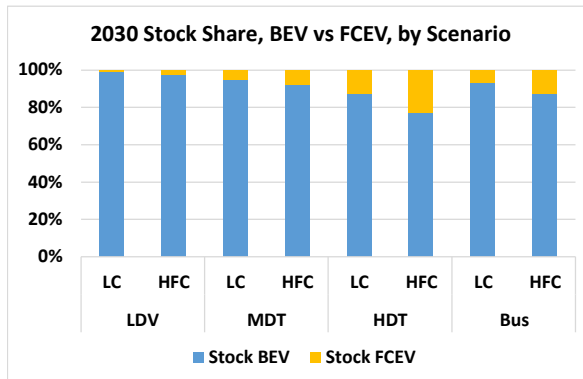

# Mapping the Potential, scenarios of all transportation modes, state-wide H2 demand

- Our ARCHES/High case shows that 75% or more of H2 demand will come from HD FC Trucks
- Port and aircraft equipment will not be significant; nor will ships; only aircraft hold any real potential, but it is likely to be small compared to road vehicles

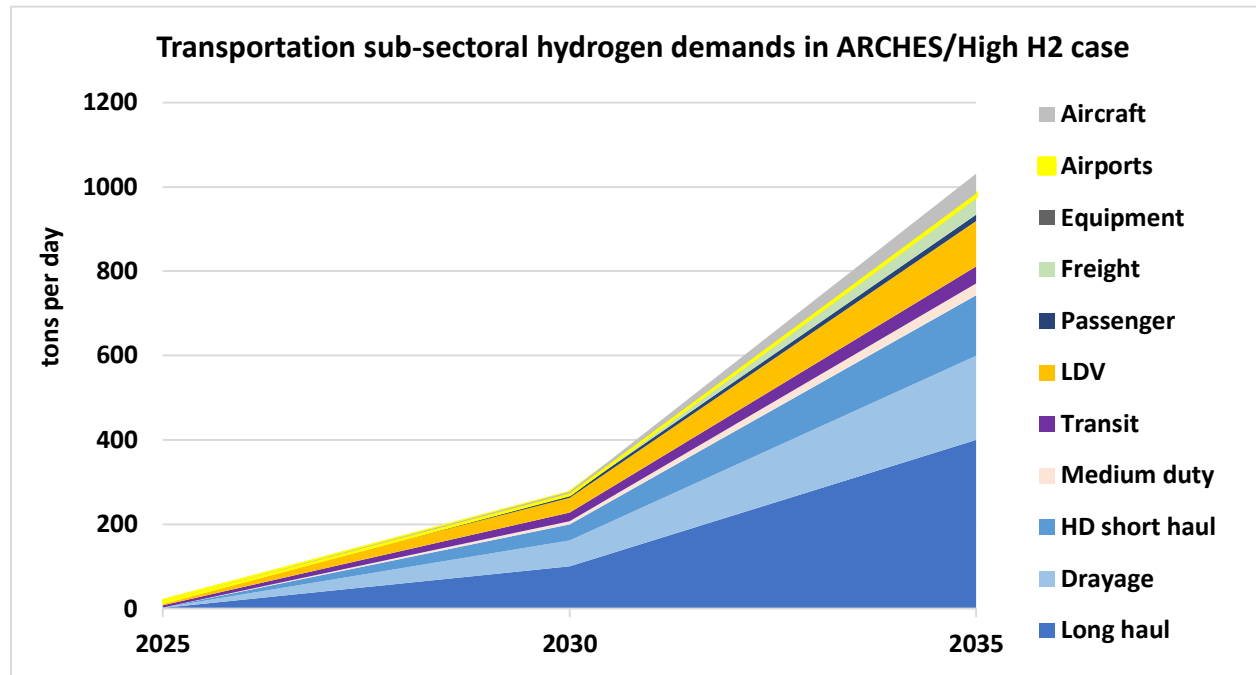

# LCA WORK INCLUDING H2 LEAKAGE

Findings presented at May Symposium and August Denver TRB conference. Initial paper submitted to TRB July 2024 and approved for presentation in January 2025.

Journal article has been submitted to IJHE (March 2025).

**UPDATE JULY 10, 2025: PAPER JUST PUBLISHED!**

Assess current understanding of leakage through literature review, reports on leakage estimates for different parts of design system, and different design features. Identified areas of concern

- Analyses for the CA and TX hydrogen hubs on system-wide CO2 emissions under different assumptions, including leakage.
  - incorporates assumptions about hydrogen production and vehicle technologies aligned with the preliminary stages of the H2Hubs while actively seeking updated information to refine environmental assessments
  - focuses on evaluating the potential greenhouse gas emissions reductions by substituting diesel in heavy-duty vehicles (HDVs) and considers the projected capacity of the hubs by 2030

Increase in GHG Emissions 2030 BAU and technology improvement scenarios due to leakage

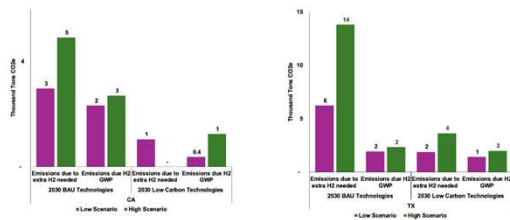

Increase in GHG Emissions 2030 BAU and technology improvement scenarios due to leakage

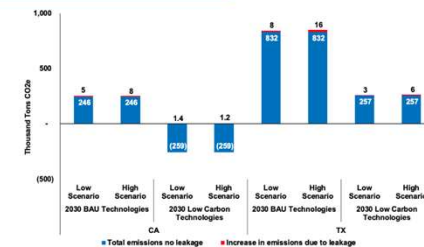

# In summary

---

- We need an on-going effort across all stakeholders to coordinate planning and investment – **ARCHES** very well placed to lead this.
  - **Investors** need some kind of security that the investments will lead to an ongoing, stable system that provides ROI
  - **H2 producers** and **station builders** need to be sure their facilities will be utilized sufficiently to avoid having to charge more per kg
  - **Truck OEMs** must believe they can sell enough trucks to be worth making investments in scale production facilities
  - **Fleets** need to be sure the trucks will be affordable and work for them
- Our policy mix must reduce costs and prices across the board (**hopefully to \$5-6/kg at the nozzle by 2030 or soon after, after all incentive programs**) and reduce uncertainty via coordinated investments and system growth
- This Policy/incentive/coordination approach will be needed for at least the next 5 and maybe next 10 years before the big bird can fly on its own...

# Completion of Battery Electric Truck Demonstration Switch-On Project

Michael Ippoliti

Senior Leader Public Partnerships, Volvo Group North America

Clean Fuels Retreat September 2025

## Switch-On Project Background

---

- Next phase of Volvo LIGHTS project
- CARB certified commercial trucks
- Largest single commercial truck deployment
- Additional performance data in drayage/freight applications
- U.S. EPA Targeted Airshed grant
- Volvo and fleets provide in-kind and cash cost share



## Project Overview

- 8 fleets participated starting at the end of 2022
- Deployed 70 battery electric trucks – largest deployment at the time
- Installed 21 chargers for 50 trucks. Other trucks used existing chargers.
- Data collection for one and a half to over two and a half years
- Over 1.9 million miles driven
- 32 tons NOx reductions in 10 years anticipated



# Trucks



69 CLASS 8  
80K TRACTORS  
1 CLASS 7  
STRAIGHT TRUCK



DRAYAGE (23)  
GENERAL FREIGHT (9)  
WHOLESALE/RETAIL (35)  
FOOD/BEVERAGE (3)



15 WITH 264 KWH  
55 WITH 564 KWH  
LITHIUM-ION  
BATTERY PACKS



ELECTRIC RANGE  
100 – 220 MILES

# Chargers



21 TOTAL  
CHARGERS  
INSTALLED

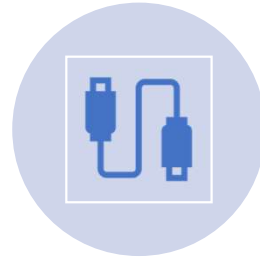

4 PORTABLE  
CHARGERS  
17 FIXED  
CHARGERS



HELIOX  
ABB  
CHARGEPOINT  
FREEWIRE



FROM 50KW TO  
250KW

# Where were the trucks used?

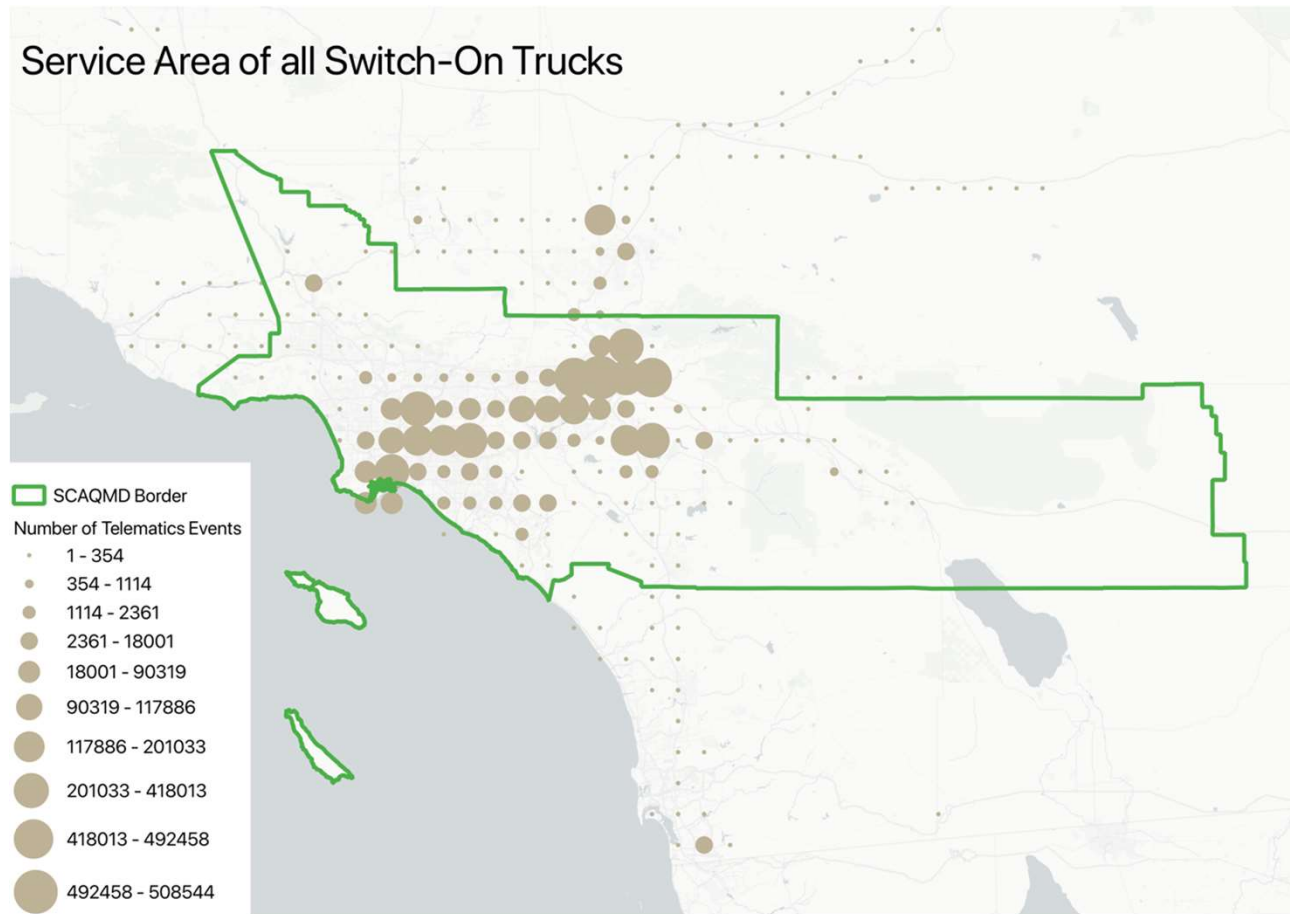

Fleets ran primarily in the South Coast Air District

# Were the trucks used to their capability?

On average, on the days the trucks were used, the trucks did not maximize battery consumption.

Two fleets expanded their SOC usage over time, the other six did not seem to.

Range anxiety and selected shorter daily routes had many of the vehicles returning with a relatively high "State of Charge" at end of the day.

State-of-Charge Ranges  
Full Project Period  
Average Maximum and Minimum Daily SOC

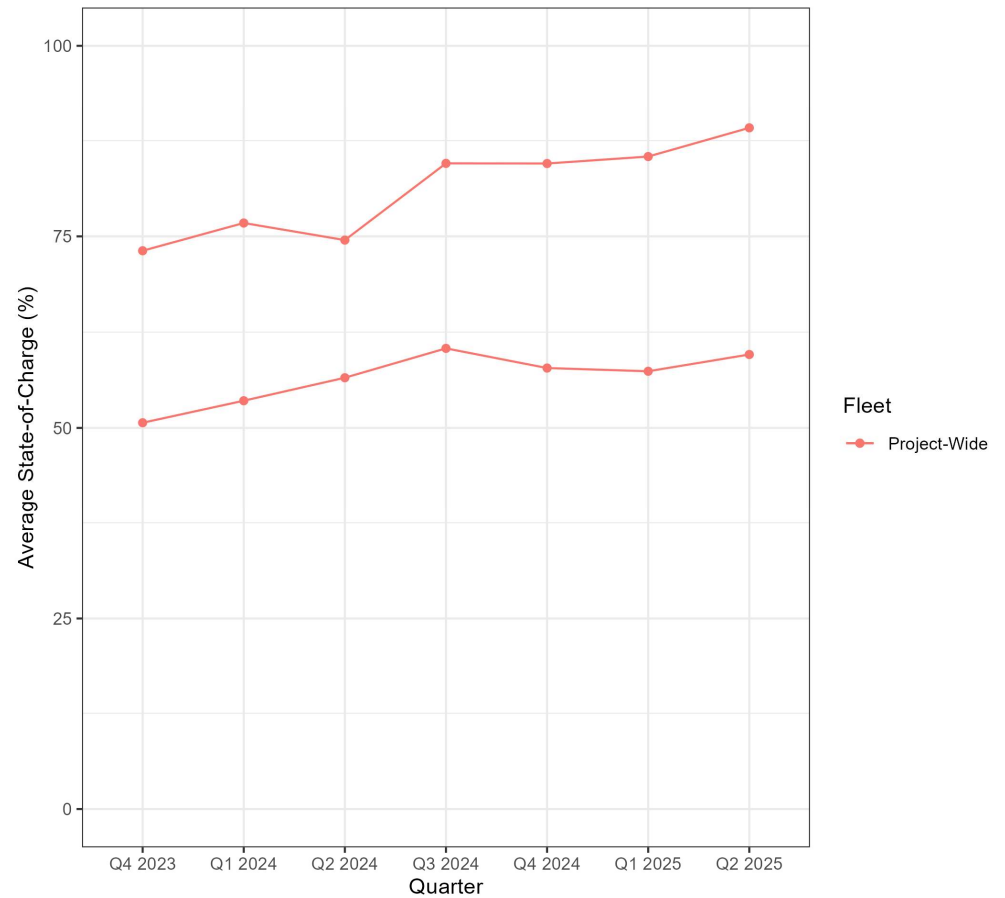

# Were the trucks utilized?

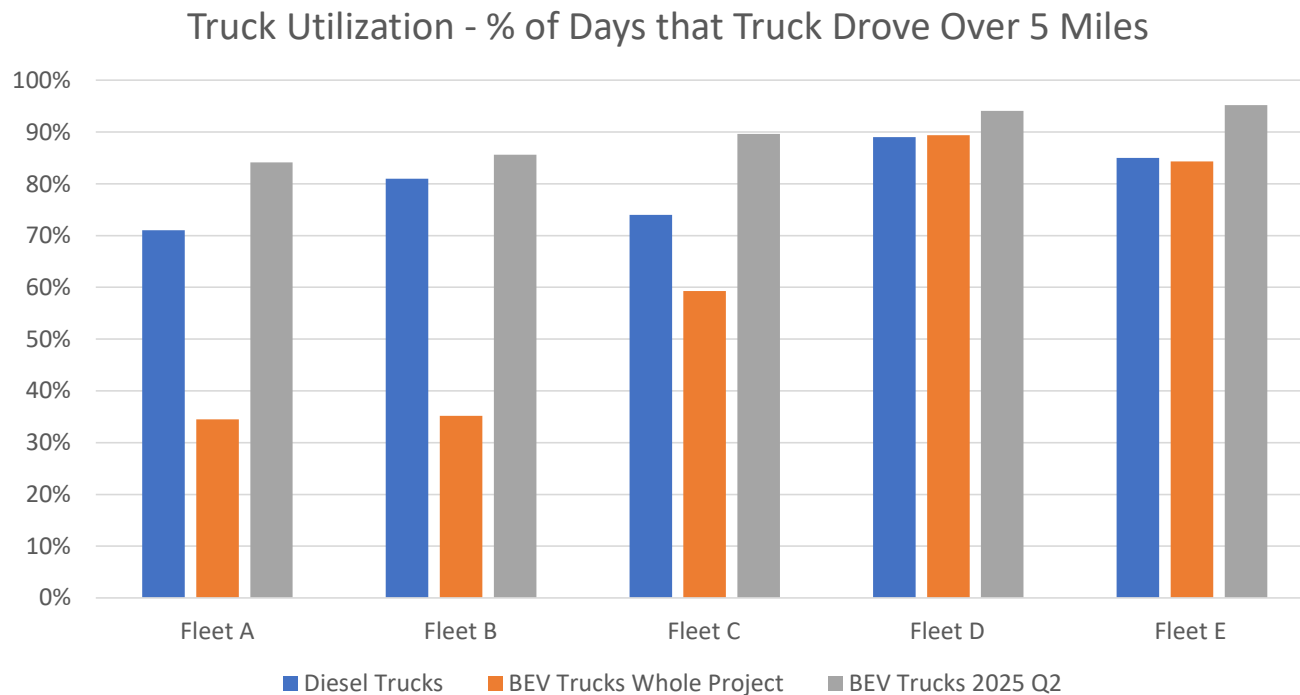

Five of the fleets also have Volvo day cab diesels in the Southern California area. (3 of the fleets did not have VTNA diesels)

The chart to the left shows the percentages of days that the trucks drove at least 5 miles.

Two fleets achieved the same utilization throughout the project.

**By the final quarter, all were utilizing their BEV trucks more than their diesels.**

# Fleet Feedback

---

- Near the end of the data collection, fleets responded to a survey to get their feedback.
- Some questions were asked to the:
  - Drivers (73 responses)
  - Fleet Managers (16 responses)
- The following slides show some of their feedback.



# Fleet Driver Feedback:

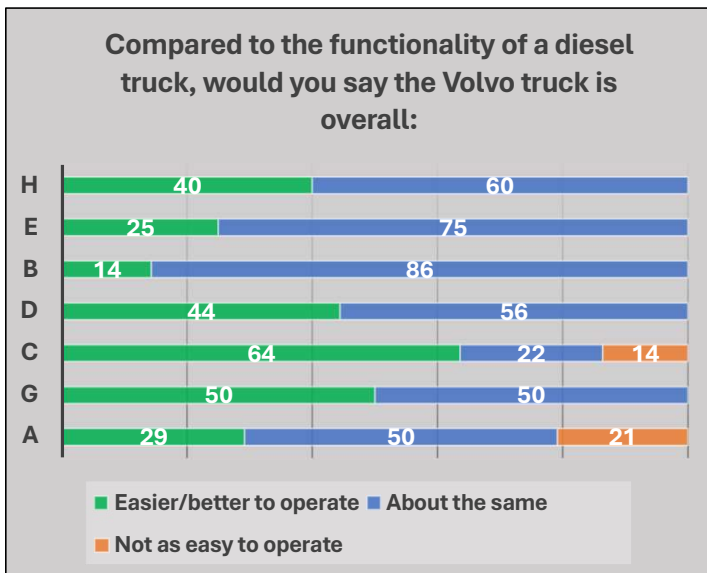

Was the BEV as functional as diesel?

- Most responded with “easier” or “about the same”

Was the BEV ride better?

- all 7 had majority of “Yes” or “Somewhat”; remaining had votes for “No”



BEV functionality and ride perceived similar to diesel vehicles in these truck applications.

# Fleet Driver Feedback:

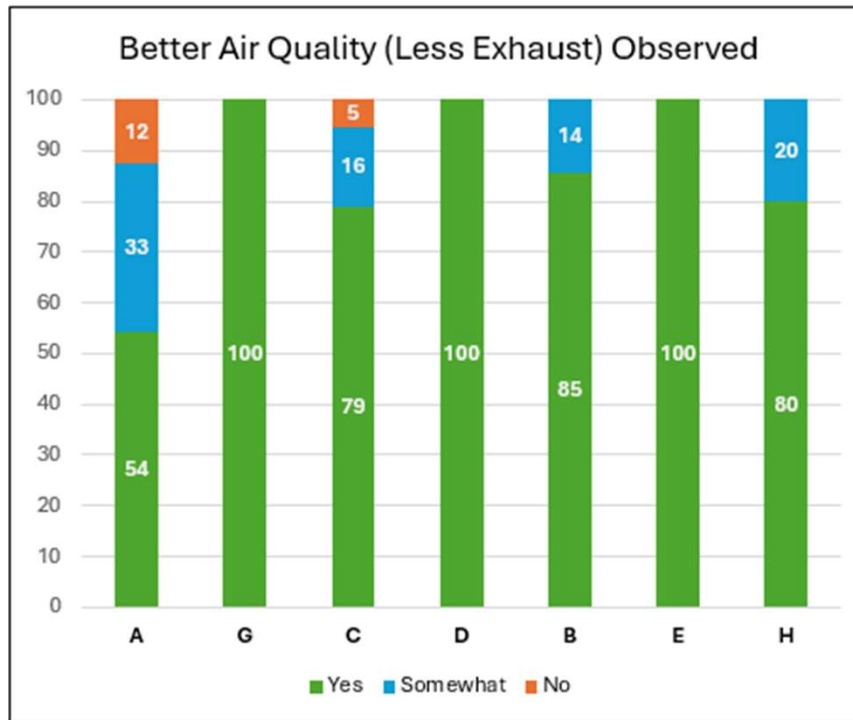

Most drivers report having noticed improvements to air quality.

# Fleet Manager Feedback:

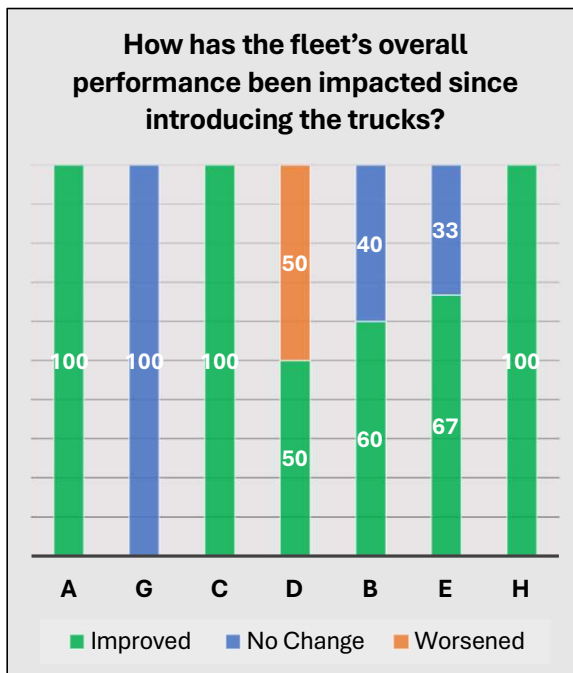

Was the fleet performance impacted?

- 7 of the 8 fleets reported "No change" or "Improved"

Was the BEV more reliable?

- Much more mixed – about half and half

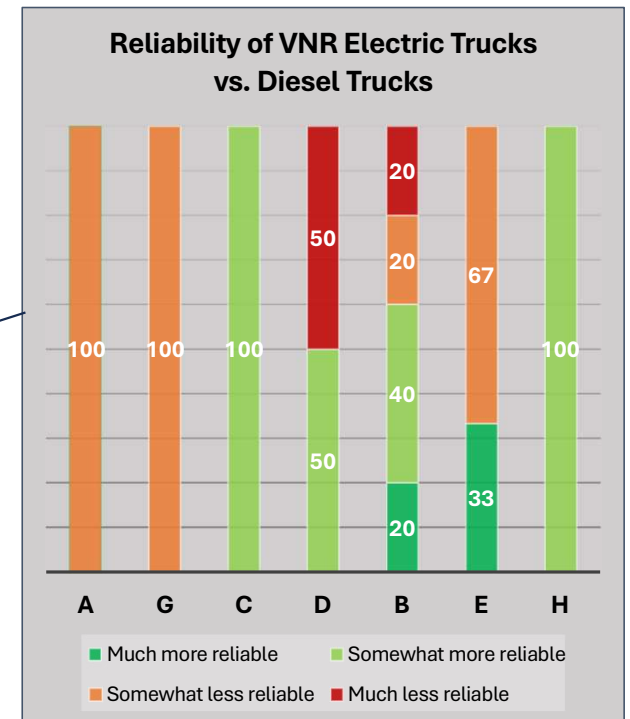

BEV performance perceived similar or better to diesel, but response on reliability was mixed.

# Take Aways:

- The 70 trucks have traveled more than 1.9 million miles, mostly in the South Coast Air Basin communities impacted by diesel emissions.
  - By the end of the data collection period, several fleets were operating their trucks at levels comparable to those of their diesel counterparts.
- The positive impact of this transition is reflected in the feedback collected from drivers and fleet managers.
  - Drivers reported smoother rides, reduced noise, and improved air quality.
  - The drivers also found that the vehicle's charging was as convenient as fueling with diesel.
  - Fleets' feedback about the vehicle's operation has generally been positive, especially as energy savings begin to emerge.
  - Systematic and consistent workforce training was identified as a key factor for successful integration.
  - Some of the challenges included manufacturing delays, slower timelines for installing the supporting truck charging infrastructure, and a limited mileage range, which impacted truck utilization among some fleets.
  - These experiences highlight the importance of aligning vehicle specifications with truck fleet needs, ensuring reliable charging, and providing consistent truck driver training and development.

END

# CHARGE-OPT: Data-Driven Planning Platforms for Charging Networks, Truck Fleets, and Power Systems – A Progress Report

Nanpeng Yu (UC Riverside)  
Jonathan Shi (AmpTrans Inc.)



# Background

## Stakeholder Challenges in MDHD Vehicle Electrification

### Fleets

- Limited charging infrastructure
- High upfront costs for electric trucks

### Utilities

- Uncertain charging demand (timing and location)
- Extended timelines for infrastructure upgrades

### Charging Station Developers

- Long wait time for energization/interconnection
- Difficulty in securing truck companies' commitment

### Overall Challenges

- Lack of coordinated decision-making platform
- Need for shared data and aligned development

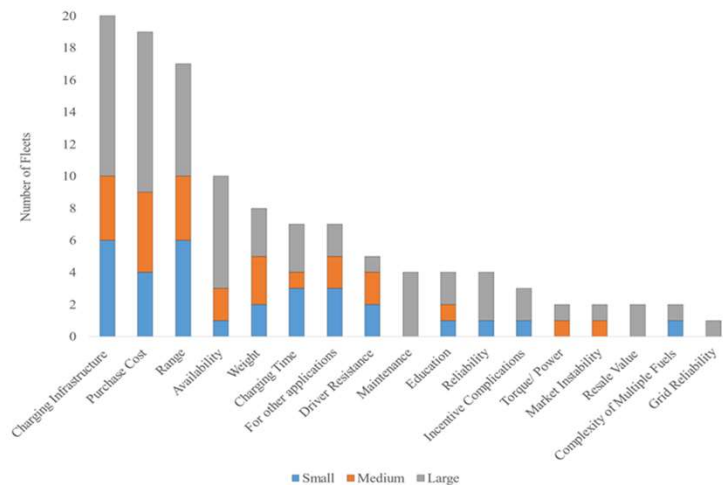

Reported barriers to fleet adoption of electric trucks by fleet size. (total 28, small 8, medium 7, large 13)

Source: C. Sugihara et al. (2023)

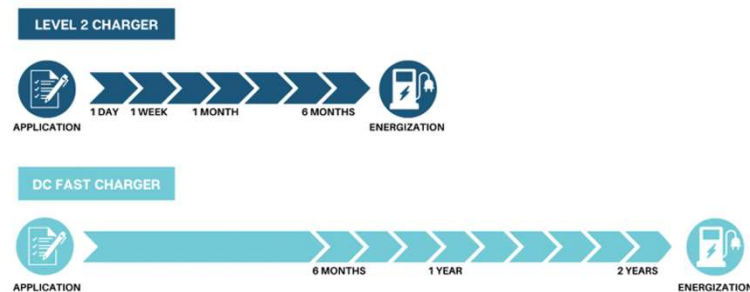

Source: IREC (2022)

# Solution

## Charging and Grid Optimization Platform for Transportation (CHARGE-OPT Platform)

### CHARGE-OPT Foundation

- CHARGE-OPT platform integrates **shared background data** – Truck traffic, existing charging infrastructure, power system capacities, policy regulation, and more, to support **coordinated planning**.

### CHARGE-OPT Modular Design

- Three modules:
  - **Fleet**
  - **Charging Station Developer**
  - **Utility**
- Each module serves the **unique interests** of the stakeholder with dedicated interface.

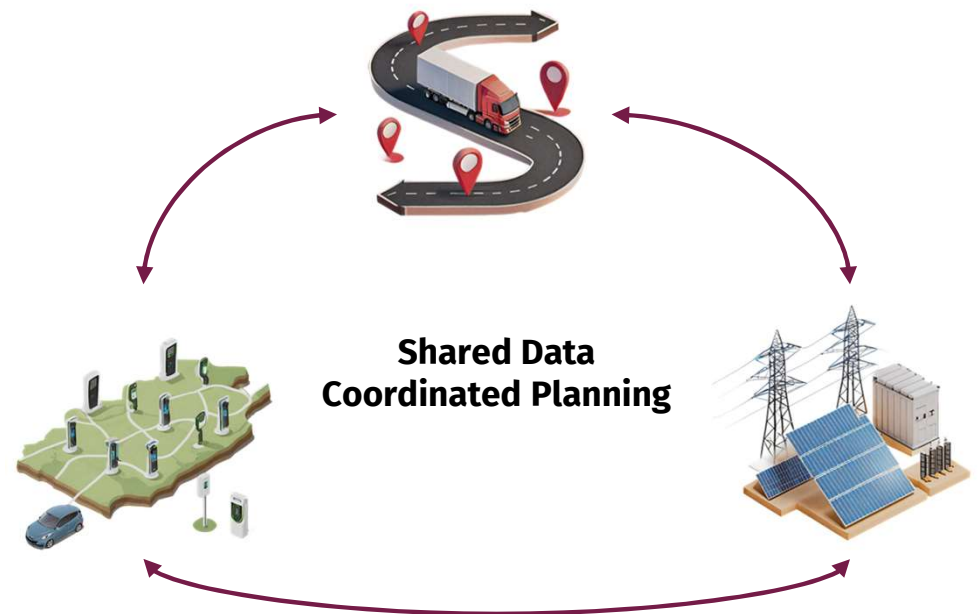

**Free access** to the CHARGE-OPT Platform is provided for analyses in SCAQMD's region (LA, San Bernardino, Riverside, and Orange counties) between **April 16, 2025 and April 15, 2027**.

# CHARGE-OPT: Fleet Module

## Optimizing Fleet Electrification Planning

Typical questions from a fleet owner:

- “Where will I charge?”
- “Which truck I should buy?”
- “Will it be reliable and affordable?”



**Module Purpose:** Support fleet owners in evaluating the **feasibility** and **economics** of transitioning to electric medium- and heavy-duty trucks.

### Key Capabilities

- **Route & Operation Analysis:**
  - Access daily trip itineraries, track SoC and identify charging opportunities
- **Depot Charging Decisions**
  - Compare own depot, third-party, or mixed charging strategies
  - Determine number, type, and power of chargers to maximize utilization
  - Evaluate grid capacity, interconnection costs, and DER options (solar + storage)
- **Truck Model Selection**
  - Compare prices, incentives, ranges, charging speeds, maintenance & insurance cost, and more
- **Energy costs**
  - Assess TOU electricity rates and demand charges, benchmark against diesel and CNG costs
- **Optimization Engine**
  - Advanced **spatio-temporal optimization engine** provides integrated results across routes, charging, vehicles, and costs



# CHARGE-OPT: Fleet Module

- Complimentary **Enterprise tier** subscription for analysis within SCAQMD jurisdiction.
- 7-step easy input process and comprehensive output results covering **financial**, **operational**, and **environmental** analysis.
- Support up to concurrent analysis of 500 routes and 20 depots.

**AMPTRANS**

Dashboard  
INPUTS  
Inputs  
ANALYTICS  
Analytics

1 Routes 2 Depots 3 Public Chargers 4 Vehicles 5 Rates 6 Parameters 7 Review Next

### Step 1: Route Selection

Select the routes you would like to include in your analysis. Each route will be assigned to a single truck. We will help you assess whether it is better served by a diesel or electric vehicle, recommend the most suitable electric truck model if applicable, and suggest the optimal charging strategy.

Show Map

Map Satellite

Features  
 Routes  
 Depots  
 Charging Stations

+ Add Route Delete Route

<input checked="" type="checkbox"/>	ROUTE NAME	ORIGIN	DESTINATION	TRAVEL DISTANCE	START TIME	TRUCK CLASS	EDIT
<input checked="" type="checkbox"/>	Ontario - City of Industry - POLB (Night Shift)	Ontario, California, United States	Ontario, California, United States	109.8 miles	22:00	Medium Duty	
<input checked="" type="checkbox"/>	Ontario - Bakersfield - POLA	Ontario, California, United States	Ontario, California, United States	337.2 miles	08:00	Heavy Duty	
<input checked="" type="checkbox"/>	Ontario - POLB - Shift 2	Ontario, California, United States	Ontario, California, United States	100.3 miles	14:28	Medium Duty	
<input checked="" type="checkbox"/>	Ontario - City of Industry - POLB	Ontario, California, United States	Ontario, California, United States	109.8 miles	09:00	Heavy Duty	
<input checked="" type="checkbox"/>	Ontario - POLA - SD	Ontario, California, United States	Ontario, California, United States	295.4 miles	08:30	Heavy Duty	
<input checked="" type="checkbox"/>	POLB to International	415 West Ocean Boulevard, Torrance, California, 90503	415 West Ocean Boulevard, Torrance, California, 90503	20.6 miles	10:51	Light Duty	

# CHARGE-OPT: Charging Station Module

## Optimizing Charging Station Planning

Typical questions from a CS developer:

- *“Will there be demand?”*
- *“Where should I build?”*
- *“Is the power grid ready?”*

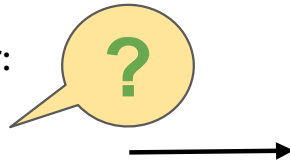

**Module Purpose:** Support developers in evaluating the appropriate land parcels for electric MDHD truck charging stations.

### Key Capabilities

- **Optimal Site Selection**
  - Analyze GPS truck trajectories, traffic volumes, warehouse locations, and dwell times
  - Identify high-potential candidate parcels across LA, San Bernardino, Riverside & Orange Counties
- **Grid & Cost Feasibility**
  - Assess feeder/substation hosting capacity, planned upgrades, and interconnection costs
  - Estimate land, equipment, and power connection costs
- **Regulatory & Incentive Integration**
  - Incorporate zoning and permitting requirements
  - Integrate environmental justice information (EPA CEJST and CalEnviroScreen)
- **Decision-Support Features**
  - Interactive geospatial visualization with multi-layer mapping
  - Smart filtering (traffic density, power capacity, zoning)
  - Side-by-side parcel comparison with standardized metrics
  - Report generation (Excel/PDF)

# CHARGE-OPT: Charging Station Module

- Complimentary services for analysis within SCAQMD jurisdiction.
- Comprehensive data layers covering transportation, existing charging infrastructure, power system, and more.
- Planned launch in **October, 2025**

**AMPTRANS**

Dashboard  
Browse  
Compare  
Additional Resources

Map Satellite

Map Features

- SCAQMD Jurisdiction
- Existing Chargers
- Warehouses
- Truck Stops
- Truck Parking
- Traffic
- Disadvantaged Communities

Search for a Land Parcel

Address

Search Clear Filters Weighted Search

Displaying 100 parcels in list  
Page 1 • 199 total results  
199 parcels shown on map  
99 more available in list

**5540 HARBOR ST COMMERCE CA 90040**

APN: 6335025009 ZIP: 90040  
Land Value: \$1,875,700 Area: 4,748 sq ft  
County: LA County Zone: Heavy Industrial  
Nearby distribution circuits: Tammy, Boris, Hosting capacity (kW): 10440, 9260, 4300  
Union Pacific  
Jurisdiction: Commerce

**350 PACIFIC AVE LA HABRA CA 90631**

APN: 01909611 ZIP: 90631  
Land Value: \$434,096 Area: 575 sq ft  
County: Orange County Zone: Heavy Industrial  
Nearby distribution circuits: Bride, Ditwood, Fonda, Hosting capacity (kW): 4650, 9520, 1820  
Jurisdiction: La Habra

**1034 BRIDGEWATER WAY COSTA MESA CA 92627**

Collapse

# Timeline, Next Steps, and More

## Project timeline:

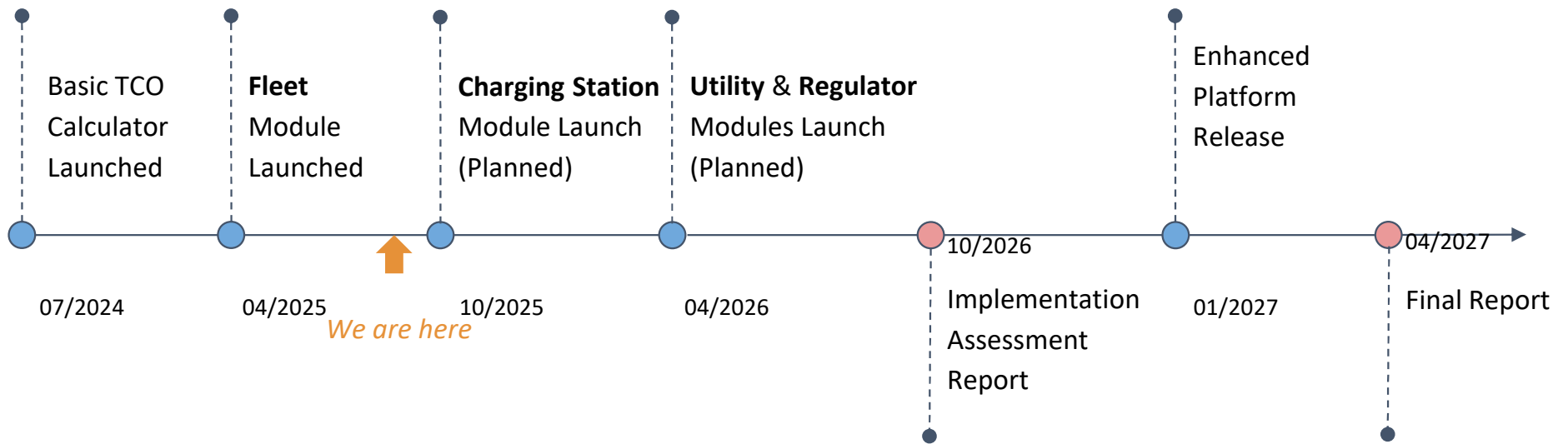

## Technical advisors from:





**Thank you!**

**Q & A**

V O L V O

# Battery Value Chain

Accelerating Electrification and Driving Circularity for a Better Tomorrow

Volvo Energy | Anna M. Axelsson

September 17, 2025

NORTH AMERICA

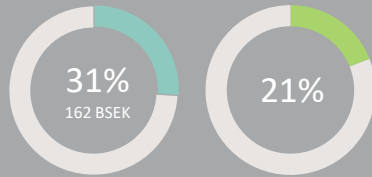

EUROPE

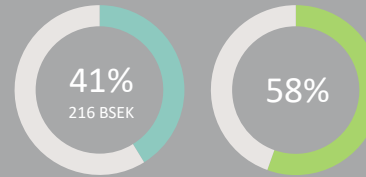

ASIA

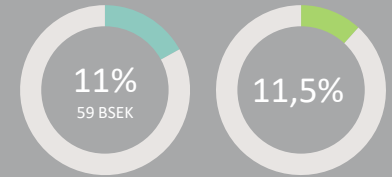

## Global presence

- 102,000 employees
- Production in 17 countries
- Sales in almost 180 markets
- Worldwide service networks and dealerships

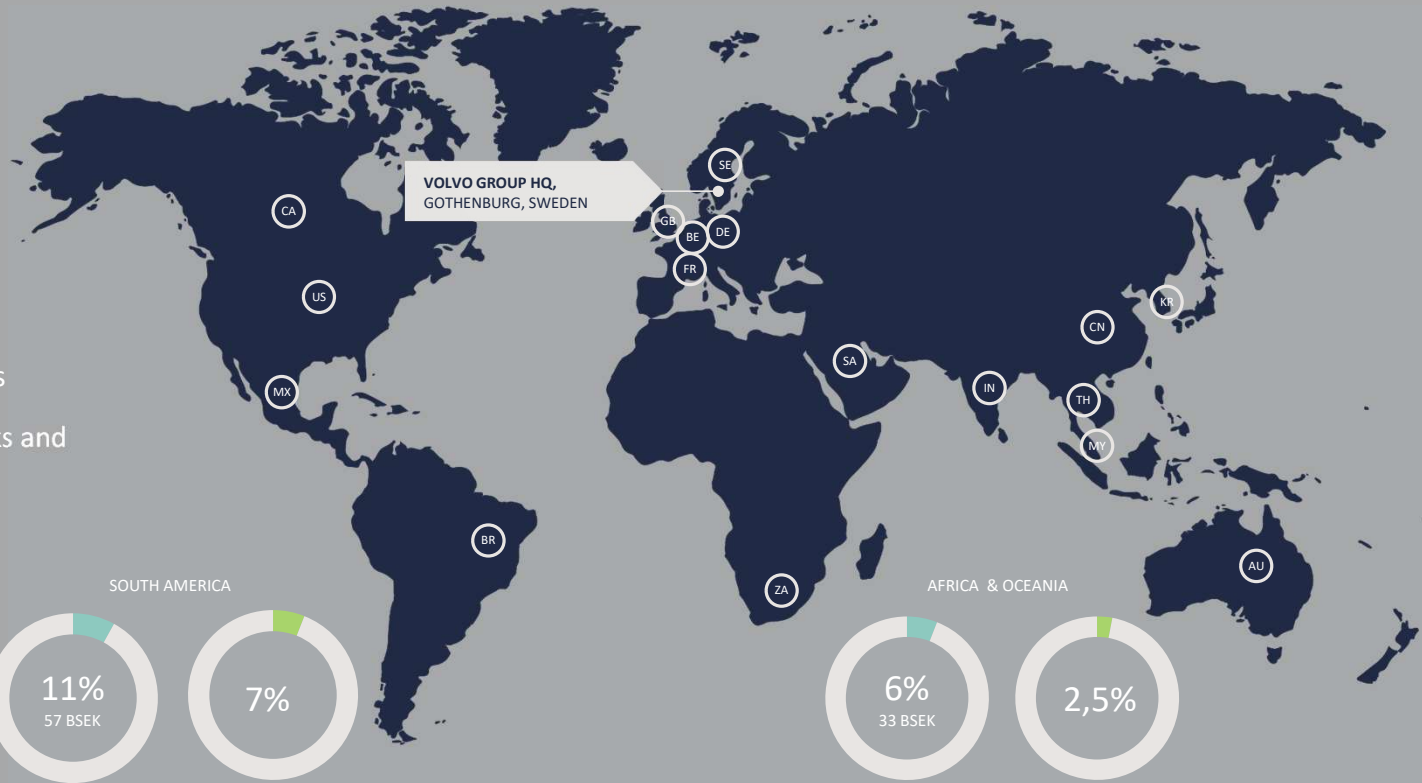

SOUTH AMERICA

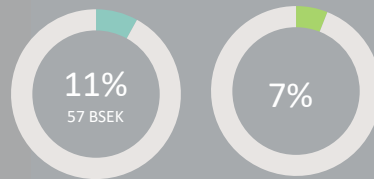

AFRICA & OCEANIA

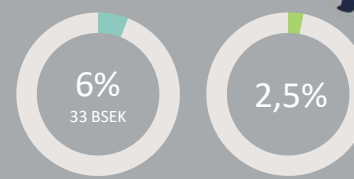

VOLVO

# Innovative since 1927

Snapshots of a history of innovation and sustainability focus.

1927  
Safety is put in focus in the very first year of Volvo's history.

1927



1966  
The world's first articulated hauler sees the light of day.

1966

1976  
The Lambda Sond is presented.

1976



1995

1995  
Volvo Trucks introduces driver airbags in heavy-duty trucks as a world first.



1959

1959  
The three-point safety belt is invented.

1972

1972  
Environmental care becomes a core value for Volvo.



1990

1990  
The Volvo Environment Prize is incepted.

2001



2001  
I-Shift becomes available.



Volvo Penta's revolutionary IPS system is revealed.

2004

2007

The world's first carbon neutral vehicle manufacturing plant opens in Ghent.



2013

Launch of Volvo Dynamic Steering.



2018

The groundbreaking Vera system puts automation in focus.



2002

Infomax from Renault Trucks premieres.

V-Eagle – Volvo Group's LGBTQ+ network is established.



2005

2010

Volvo Group joins WWF's Climate Savers program.



2015

The ElectricCity project takes place in Gothenburg

Results from the Electric Site research project shows a 98% reduction in CO<sub>2</sub> emissions.

2018

2020

Volvo Group commits to the goals of the Paris Agreement.



2022

Volvo Group starts series production of electric heavy-duty trucks – completing the range.

Video of various electric heavy-duty trucks not available online



V O L V O

## Future-proofing Volvo Group

With a total of 12 brands, Volvo Group offers trucks, buses, construction equipment, power solutions for marine and industrial applications, financing and services – for the benefit of customers, society and for the environment.



V O L V O

We are here to make a fundamental  
breakthrough by accelerating electrification and  
driving circularity for a better tomorrow.

# Volvo Energy

# What is battery circularity?



## OUR AMBITION

Maximizing environmental and economic value through a holistic battery circularity model, ensuring safety, compliance, and efficiency at every stage.

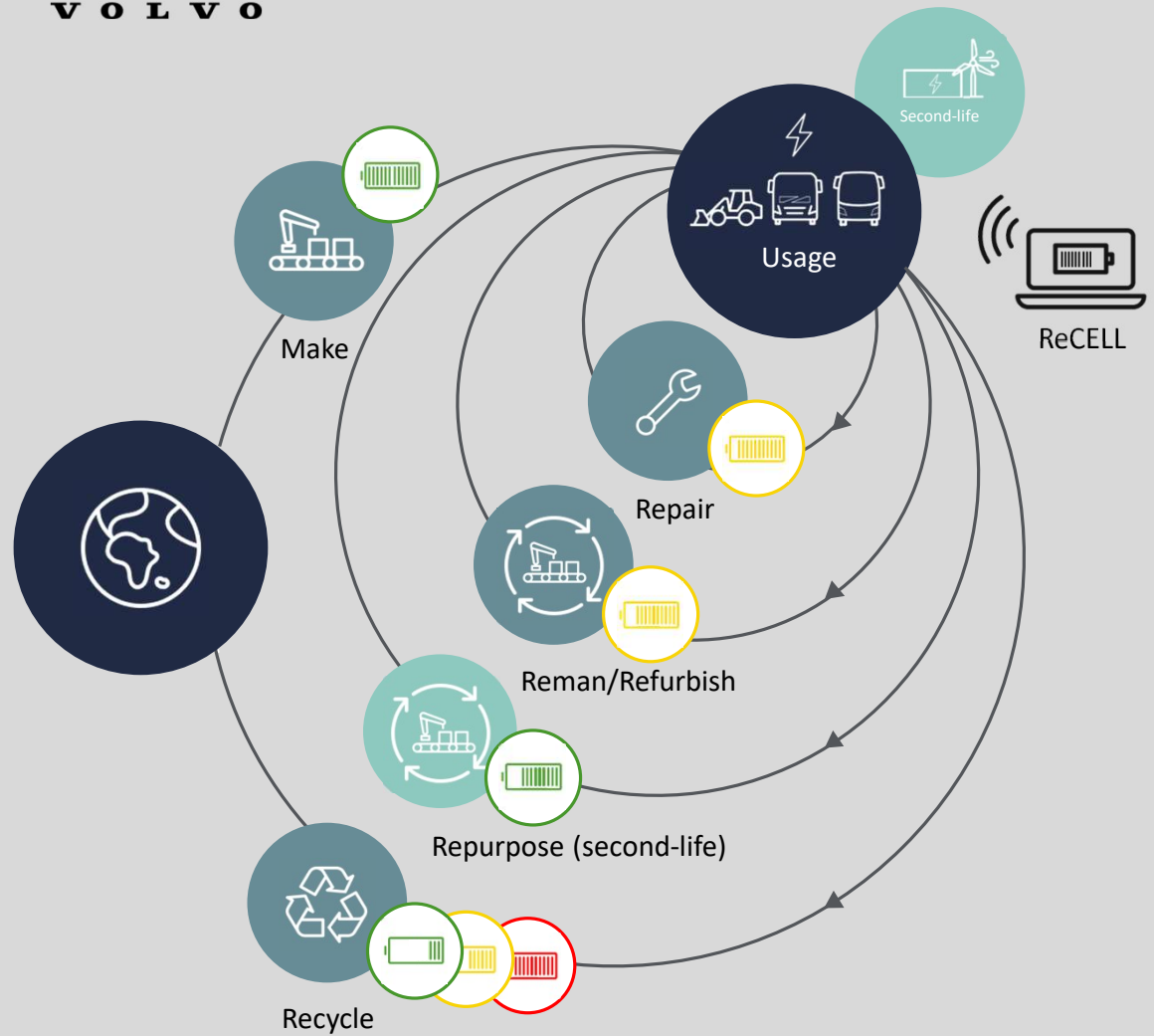

VOLVO

## Power in Layers: High Voltage Battery Overview



VOLVO

## Monitor and optimize batteries

Optimize Volvo Group's capabilities and offerings in electric solutions

- Battery optimization whilst onboard customers' vehicles
- Battery solutions development support across the Volvo Group
- Battery life expectancy based on State of Health



VOLVO

## Secure charging infrastructure and related e-mob services

Achieve a fundamental breakthrough in electrification, we must develop a reliable charging infrastructure.

- Secure charging solutions for battery electric vehicles
- Cover entire transport mission i.e., home-depot, en-route and destination charging
- Strive to secure 100% green energy

VOLVO

## Repair, Remanufacturing & Refurbishing

Minimize the environmental impact of our electrified products, we extend the life of the batteries for all applications before recycling:

- Repair on-site to minimize downtime
- Refurbish batteries where only problematic components are exchanged
- Remanufacture batteries to get them back to “as-good-as new” performance

VOLVO

## Repurposing

Battery Energy Storage System (BESS) has the potential to become a vital component in the energy landscape.

- Reliable source of power that can help reduce emissions, optimize energy costs, and promote a stronger, greener grid.
- Repurpose the batteries that has powered our vehicles for their second life.



## Recycling

Recycle batteries to recover the raw materials to be re-injected in a closed loop process

- Delay environmental impact of recycling batteries after first life.
- Plan and optimize the logistics of used and renovated batteries including the industrial footprint
- Secure design requirements for optimal battery circular operations
- Recycling efficiency and chemistry

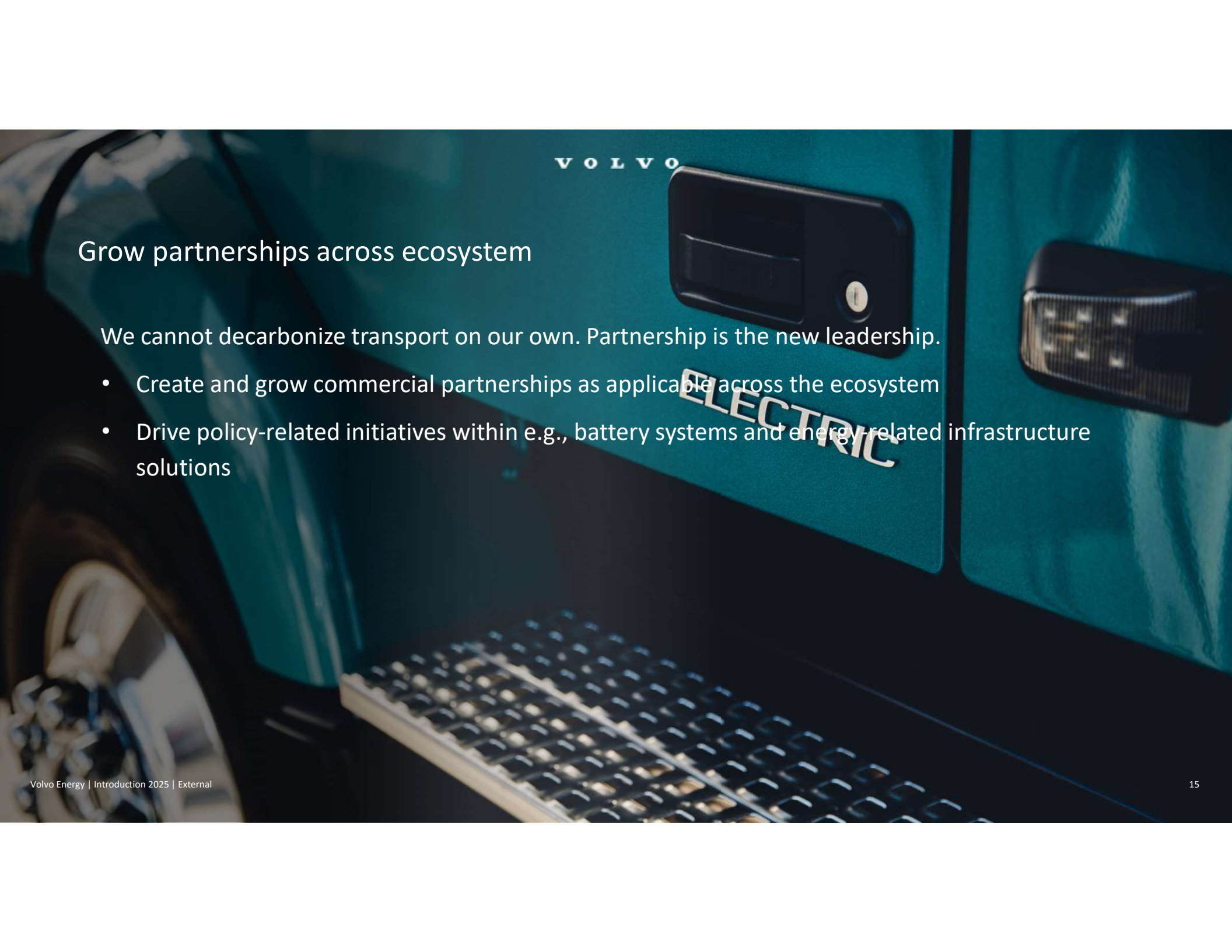

## Grow partnerships across ecosystem

We cannot decarbonize transport on our own. Partnership is the new leadership.

- Create and grow commercial partnerships as applicable across the ecosystem
- Drive policy-related initiatives within e.g., battery systems and energy-related infrastructure solutions

V O L V O

# Accelerating electrification and driving circularity for a better tomorrow

---

#volvoenergy 



# Clean Fuels Program

Technology Advancement Office

*Leading the way to cleaner air*



South Coast  
AQMD

South Coast  
Air Quality  
Management  
District



# Clean Fuels Program Advisory Group Meeting

September 17, 2025

Vasileios Papapostolou, Sc.D.  
Technology Demonstration Manager

The 2026 Plan Update

# Clean Fuels Program - Overview

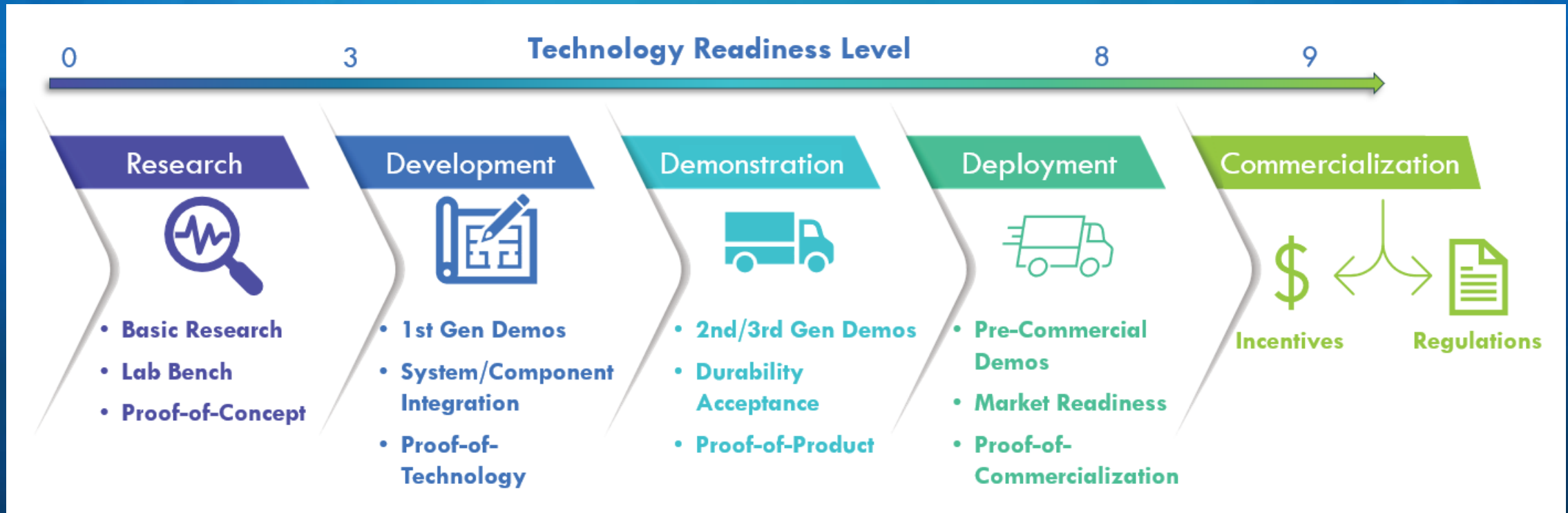

# Proposed 2026 Clean Fuels Plan Distribution

**\$29.3M**

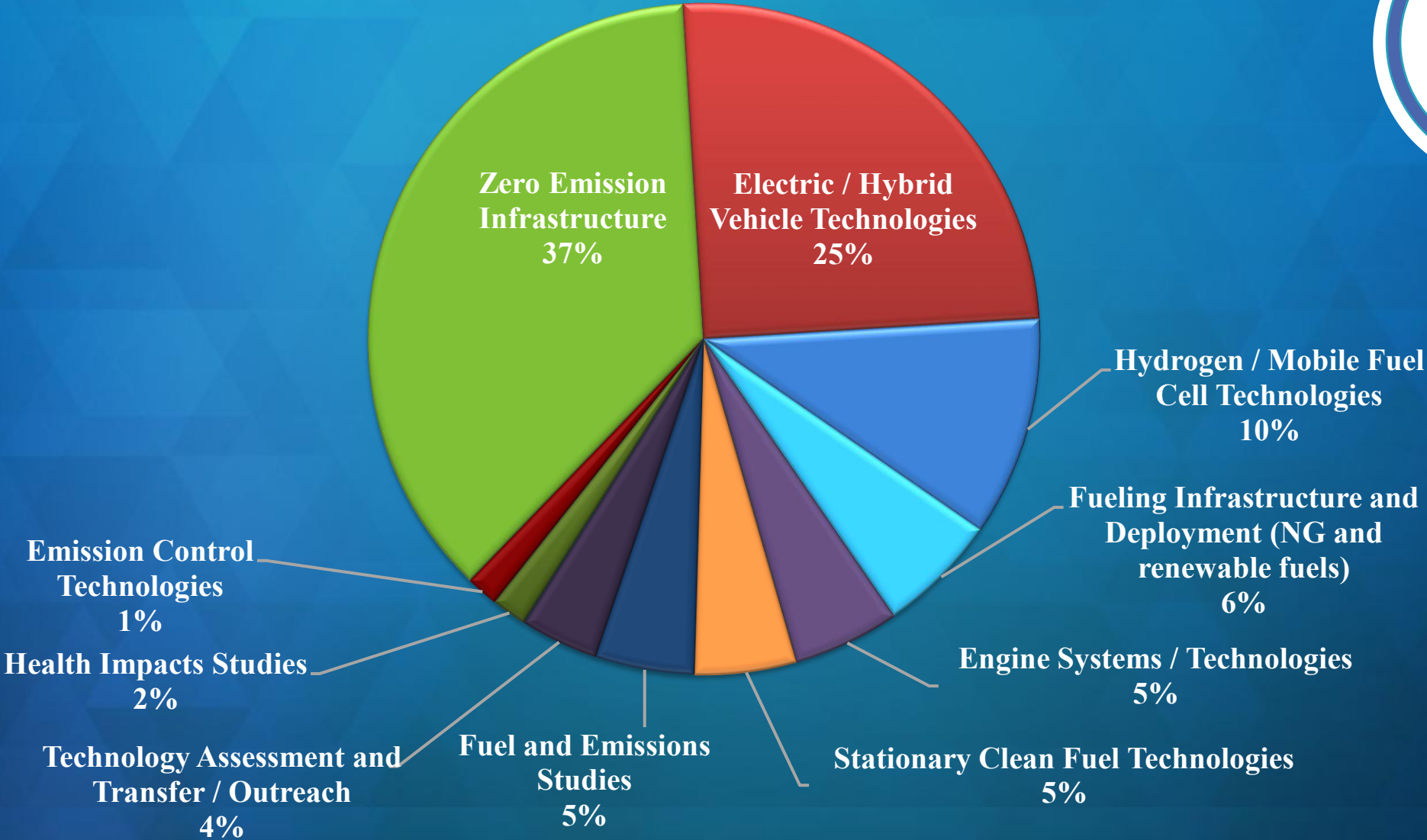

# Draft 2026 Clean Fuels Plan Update

## Focus Areas

### **ZE Infrastructure (37%):**

- Increase Infrastructure Deployment to Support Large Scale Deployments
- Research How to Reduce the Cost of Hydrogen to Support Infrastructure
- Low-emissions Generation Technology/Power microgrids Explored to Provide Prime and Backup Power (battery storage)
- Battery Integrated EV Chargers and Battery Powered Microgrids

### **Hydrogen / Mobile Fuel Cell Technologies (10%):**

- Large-Scale Deployment of Class 6-8 Vehicles
- Hydrogen Fuel Cell Electric Powertrain Technology

# Draft 2026 Clean Fuels Plan Update

## Focus Areas (cont.)

### **Vocational Applications of Core Technology Areas:**

- All-Electric Transportation Refrigeration Units (TRU)
- Electrified Power-Take-Off Systems

### **Research at Academic Institutions (e.g., technoeconomic analysis, environmental impact assessment):**

- Hydrogen Fuel-Cell Electric and Battery Electric Technologies and Equipment
- Criteria Pollutants Monitoring at Freight Corridors
- Marine Sector Projects, Tractor Projects, Other Vocational Sectors projects where application of the core technologies have yet to be explored

# Proposed Projects for 2026

## Develop and/or Demonstrate Hydrogen Fuel-Cell Electric (FCE)

- Class 6-8 Drayage Truck(s)
- Hybrid Powertrain
- Refuse Truck
- Cargo Handling Equipment
- Mobile/Portable Refueler for Hydrogen FCE Off-Road Technologies (e.g., vessel, locomotive)
- Hydrogen Production Pilot Plant (300kg/day to 20+ ton/day)



# Proposed Projects for 2026

Develop and/or Demonstrate

- All-Electric Transport Refrigeration Unit (TRU) trailers
- Battery-electric Class 8 Cement Truck
- Linear Generators for Prime Power Use and Microgrid Application(s)
- Charging Microgrid Application(s) using methanol reforming to produce electricity from hydrogen



# Proposed Projects for 2026 (cont.)

## Support Research conducted by Academic Institutions

- Mobile Battery-Integrated EV Chargers To Accelerate Medium- and Heavy-Duty (MHD) On-Road BE Vehicle Deployment
- Battery Swap For MHD On-Road BE Vehicles and Equipment
- Secondary PM Formation in Tire Emissions
- Monitor Urban NH<sub>3</sub> and NO<sub>x</sub> For Potential Emission Sources (e.g., target freeways, near warehouses)

# Feedback

Email

Vasileios Papapostolou, Sc.D.  
[vpapapostolou@aqmd.gov](mailto:vpapapostolou@aqmd.gov)

or

Aaron Katzenstein, Ph.D.  
[ak Katzenstein@aqmd.gov](mailto:ak Katzenstein@aqmd.gov)